

holding system



PH6600

PH6800

PH6400

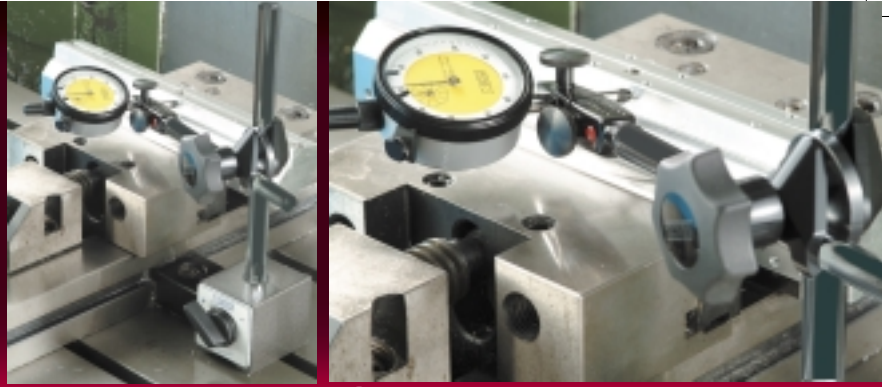

POST HOLDERS FAT

NOGA economical holders with fine adjustment on top

NOGA PH (Post Holder) holders are the latest improvement of the traditional indicator holder.

- New fine adjustment on the top with universal swivel clamp.
- Holds 6mm, 8mm, 3/8", dovetail and back lug.
- Powerful on/off magnetic base.
- Strong arm lock by using 3 points clamp.
- Easy to set up gauges into required position.
- Black finished arms.

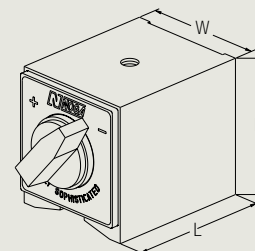
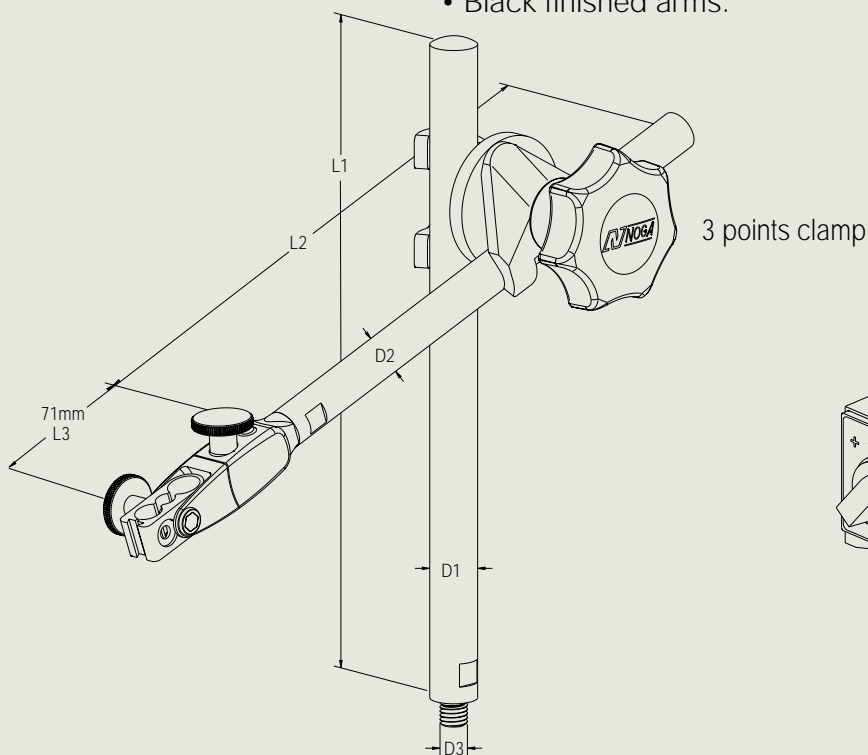

see page 18

All measurements are in mm unless otherwise mentioned.

Order no.	Holder		Arm length and diameter		Force [N]	Magnet			3 points clamp Order no.
	Bottom thread	Weight [Kg]	Post Dia. (D1) x length (L1)	Arm Dia. (D2) x length (L2)		Dimension			
	D3					W	L	H	
PH6400	M8	1.700	ø14 x 203	ø12 x 185	800	50	60	55	PH0310
PH6410	M8	0.700	ø14 x 203	ø12 x 185	-	-	-	-	PH0310
PH6600	M8	2.300	ø16 x 260	ø16 x 225	1000	50	75	55	PH0312
PH6610	M8	1.070	ø16 x 260	ø16 x 225	-	-	-	-	PH0312
PH6800	M10 x 1.25	3.450	ø18 x 350	ø16 x 225	1300	50	120	55	PH0313
PH6810	M10 x 1.25	1.450	ø18 x 350	ø16 x 225	-	-	-	-	PH0313