

# M Metric coarse threads

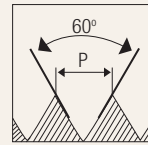

HSS
CS
BS 1127
6G

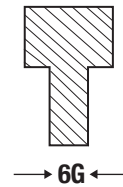
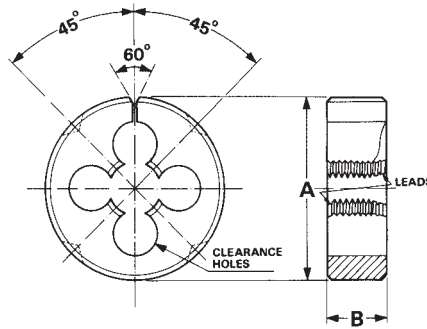

Unit : mm

Nominal Diameter	Pitch	Outer Diameter	HSS	Carbon Steel	Thickness	Clearance Holes	Threading Diameter
ØD	p	A	EDP No.	EDP No.	B		
M 20	2.5	2"	FBC0201910	FBB0201931	5/8"	5	19.88
M 22	2.5	2"	FBC0201934	FBB0201949	5/8"	5	21.88
M 24	3	2"	FBC0201958	FBB0201968	5/8"	5	23.88
M 27	3	2.1/4"	FBM2300071	FBM2300344	11/16"	6	
M 30	3.5	2.1/4"	FBM2300084	FBM2300364	11/16"	6	
M 33	3.5	2.1/4"	FBM2300094	FBM2300377	11/16"	6	
M 36	4	2.1/2"	FBM2300106	FBM2300391	7/8"	6	
M 36	4	3"	FBM2300107	FBM2300392	7/8"	6	
M 39	4	3"	FBM2300113	FBM2300402	7/8"	6	
M 42	4.5	3"	FBM2300120	FBM2300408	7/8"	6	
M 48	5	4"	FBM2300130	FBM2300413	1"	6	



**MF**

**Metric fine threads**

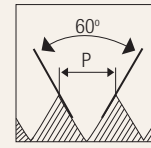

HSS
CS
BS 1127
6G

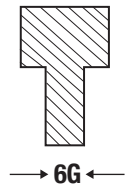
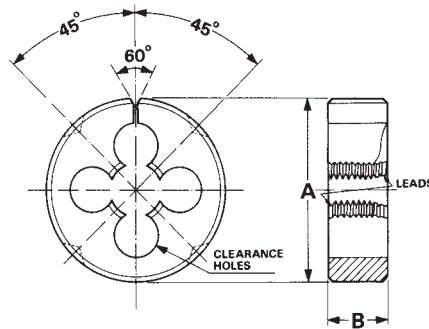

Unit : mm

Nominal Diameter	Pitch	Outer Diameter	HSS	Carbon Steel	Thickness	No. Clearance Hole	Threading Diameter
ØD	p	A	EDP No.	EDP No.	B		
M 1.6	0.35	13/16"	FBC0201092	FBB0201143	1/4"	3	1.56
M 2.2	0.45	13/16"	FBC0201109	FBB0201160	1/4"	3	2.15
M 2.3	0.4	13/16"	FBC0201115	FBB0201169	1/4"	3	2.25
M 2.5	0.45	13/16"	FBC0201121	FBB0201173	1/4"	3	2.45
M 2.6	0.45	13/16"	FBC0201132	FBB0201182	1/4"	3	2.55
M 3	0.6	13/16"	FBC0201161	FBB0201209	1/4"	3	2.96
M 3.5	0.6	13/16"	FBC0201167	FBB0201218	1/4"	3	3.46
M 4	0.5	13/16"	FBC0201184	FBB0201231	1/4"	3	3.95
M 4	0.75	13/16"	FBC0201212	FBB0201261	1/4"	3	3.95
M 4.5	0.5	13/16"	FBC0201218	FBB0201270	1/4"	3	4.45
M 4.5	0.75	13/16"	FBC0201224	FBB0201275	1/4"	3	4.45
M 5	0.5	13/16"	FBC0201235	FBB0201284	1/4"	3	4.95
M 5	0.75	13/16"	FBC0201241	FBB0201297	1/4"	3	4.95
M 5	0.9	13/16"	FBC0201274	FBB0201323	1/4"	3	4.95
M 5.5	0.5	13/16"	FBC0201280	FBB0201331	1/4"	4	5.45
M 5.5	0.9	13/16"	FBC0201292	FBB0201335	1/4"	4	5.45
M 6	0.5	13/16"	FBC0201298	FBB0201343	1/4"	4	5.95
M 6	0.75	13/16"	FBC0201310	FBB0201353	1/4"	4	5.95
M 7	0.75	13/16"	FBC0201373	FBB0201393	1/4"	4	6.95

**MF**

**Metric fine threads**

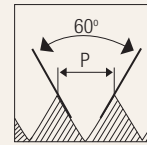

**HSS** **CS** **BS 1127** **6G**

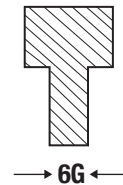
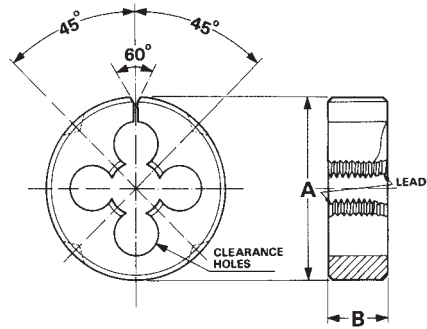

Unit : mm

Nominal Diameter	Pitch	Outer Diameter	HSS	Carbon Steel	Thickness	No. Clearance Hole	Threading Diameter
ØD	p	A	EDP No.	EDP No.	B		
M 6	0.5	1"	FBC0201304	FBB0201348	3/8"	4	5.95
M 6	0.75	1"	FBC0201316	FBB0201358	3/8"	4	5.95
M 7	0.75	1"	FBC0201379	FBB0201398	3/8"	4	6.95
M 8	0.75	1"	FBC0201408	FBB0201429	3/8"	4	7.97
M 8	1	1"	FBC0201420	FBB0201434	3/8"	4	7.93
M 9	0.75	1"	FBC0201453	FBB0201482	3/8"	4	8.95
M 9	1	1"	FBC0201464	FBB0201487	3/8"	4	8.93
M 10	0.5	1"	FBC0201481	FBB0202548	3/8"	4	9.93
M 10	0.75	1"	FBC0201487	FBB0201509	3/8"	4	9.95
M 10	1	1"	FBC0201499	FBB0201518	3/8"	4	9.93
M 10	1.25	1"	FBC0201516	FBB0201535	3/8"	4	9.93
M 11	1	1.1/2"	FBC0201554	FBB0201597	1/2"	5	10.93
M 11	1.5	1.1/2"	FBC0201576	FBB0201613	1/2"	4	10.91
M 12	1	1.1/2"	FBC0201604	FBB0201634	1/2"	5	11.93
M 12	1.25	1.1/2"	FBC0201620	FBB0201647	1/2"	5	11.92
M 12	1.5	1.1/2"	FBC0201636	FBB0201668	1/2"	4	11.91
M 14	1	1.1/2"	FBC0201685	FBB0201726	1/2"	5	13.93
M 14	1.25	1.1/2"	FBC0201696	FBB0201731	1/2"	5	13.92



Round Split Dies

HSS TAPS

DIES

END MILLS

DRILLS

CARBIDE BURRS

CS TAPS

MF

**Metric fine threads**

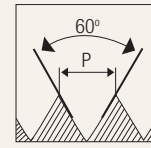

HSS
CS
BS 1127
6G

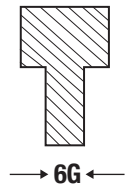
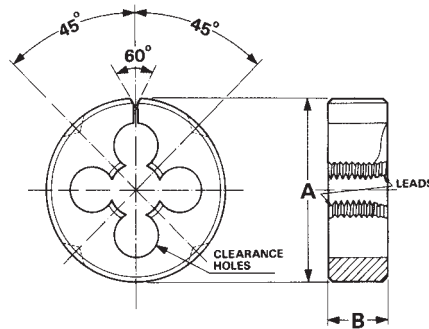

Unit : mm

Nominal Diameter	Pitch	Outer Diameter	HSS	Carbon Steel	Thickness	No. Clearance Hole	Threading Diameter
ØD	p	A	EDP No.	EDP No.	B		
M 14	1.5	1.1/2"	FBC0201707	FBB0201744	1/2"	5	13.91
M 15	1.5	1.1/2"	FBC0201757	FBB0201786	1/2"	5	14.91
M 16	1	1.1/2"	FBC0201763	FBB0201795	1/2"	5	15.93
M 16	1.5	1.1/2"	FBC0201781	FBB0201813	1/2"	5	15.91
M 18	1.5	1.1/2"	FBC0201820	FBB0201861	1/2"	6	17.91
M 20	1.5	1.1/2"	FBC0201874	FBB0201902	1/2"	6	19.91
M 20	1.5	2"	FBC0201880	FBB0201907	5/8"	5	19.91
M 22	1.5	2"	FBC0201922	FBB0201940	5/8"	6	21.91
M 24	1	2"	FBC0201940	FBB0201953	5/8"	6	23.93
M 24	1.5	2"	FBC0201946	FBB0201958	5/8"	6	23.90
M 25	1.5	2"	FBC0201970	FBB0201977	5/8"	6	24.91
M 26	1.5	2"	FBC0201988	FBB0201986	5/8"	6	25.90
M 27	1.5	2"	FBC0202000	FBB0202641	5/8"	6+6	26.9
M 28	1.5	2"	FBC0202012	FBB0202711	5/8"	6+6	27.9
M 30	1.5	2"	FBC0202024	FBB0201991	5/8"	6+6	29.9
M 32	1.5	2.1/4"	FBM2300087	FBM2300368	11/16"	6+6	
M 33	1.5	2.1/4"	FBM2300091	FBM2300595	11/16"	6+6	



**MF**

**Metric fine threads**

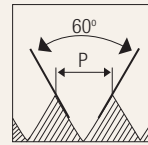

**HSS** **CS** **BS 1127** **6G**

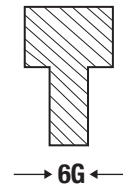
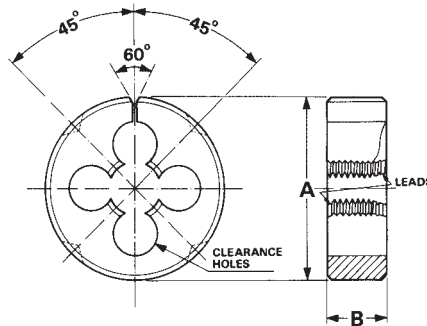

Unit : mm

Nominal Diameter	Pitch	Outer Diameter	HSS	Carbon Steel	Thickness	No. Clearance Hole	Threading Diameter
ØD	p	A	EDP No.	EDP No.	B		
M 34	1.5	2.1/2"	FBM2300097	FBM2300381	7/8"	6	
M 35	1.5	2.1/2"	FBM2300100	FBM2300383	7/8"	6	
M 36	1.5	2.1/2"	FBM2300102	FBM2300385	7/8"	6	
M 40	1.5	2.1/2"	FBM2300114	FBM2300404	7/8"	6	
M 34	1.5	3"	FBM2300098	FBM2300382	7/8"	6	
M 35	1.5	3"	FBM2300101	FBM2300384	7/8"	6	
M 36	1.5	3"	FBM2300103	FBM2300386	7/8"	6	
M 38	1.5	3"	FBM2300109	FBM2300396	7/8"	6	
M 45	1.5	3"	FBM2300123	-	7/8"	6	
M 45	1.5	4"	FBM2300124	FBM2300410	1"	6	
M 46	1.5	4"	FBM2300126	FBM2300411	1"	6	
M 48	1.5	4"	FBM2300127	FBM2300412	1"	8	
M 50	1.5	4"	FBM2300131	FBM2300414	1"	6	
M 52	1.5	4"	FBM2300132	FBM2300415	1"	6	
M 55	1.5	4"	FBM2300133	FBM2300416	1"	6	
M 60	1.5	4"	FBM2300134	FBM2300418	1"	6	



Round Split Dies

HSS TAPS

DIES

END MILLS

DRILLS

CARBIDE BURRS

CS TAPS

**BSW**

**Whitworth coarse threads**

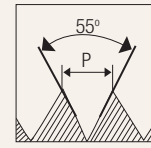

HSS

CS

BS  
1127

6G

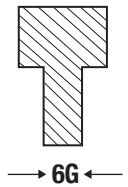
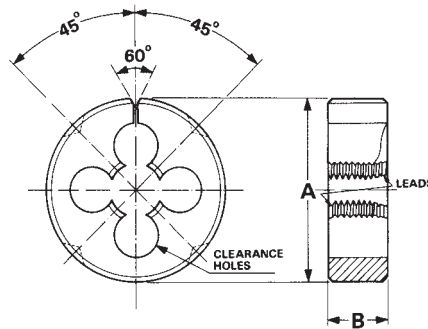

Unit : mm

Nominal Diameter ØD	TPI	Outer Diameter A	HSS	Carbon Steel	Thickness B	No. Clearance Hole	Threading Diameter
			EDP No.	EDP No.			
1/16"	60	13/16"	FBC0200001	FBB0200001	1/4"	3	1.56
3/32"	48	13/16"	FBC0200007	FBB0200005	1/4"	3	2.35
1/8"	40	13/16"	FBC0200013	FBB0200017	1/4"	3	3.14
5/32"	32	13/16"	FBC0200019	FBB0200034	1/4"	3	3.93
3/16"	24	13/16"	FBC0200036	FBB0200051	1/4"	3	4.72
7/32"	24	13/16"	FBC0200047	FBB0200064	1/4"	4	5.51
1/4"	20	13/16"	FBC0200059	FBB0200081	1/4"	4	6.31
1/4"	20	1"	FBC0200071	FBB0200090	3/8"	3	6.31
9/32"	20	1"	FBC0200089	FBB0200111	3/8"	4	7.10
5/16"	18	1"	FBC0200101	FBB0200119	3/8"	4	7.88
3/8"	16	1"	FBC0200128	FBB0200144	3/8"	4	9.47
7/16"	14	1.1/2"	FBC0200159	FBB0200173	1/2"	4	11.05
1/2"	12	1.1/2"	FBC0200181	FBB0200197	1/2"	4	12.63
9/16"	12	1.1/2"	FBC0200198	FBB0200210	1/2"	5	14.21
5/8"	11	1.1/2"	FBC0200210	FBB0200223	1/2"	5	15.80
11/16"	11	1.1/2"	FBC0200221	FBB0200232	1/2"	6	17.39
3/4"	10	1.1/2"	FBC0200233	FBB0200244	1/2"	6	18.97



Round Split Dies

HSS TAPS

DIES

END MILLS

DRILLS

CARBIDE BURRS

CS TAPS

**BSW**

**Whitworth coarse threads**

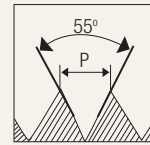

**HSS** **CS** **BS 1127** **6G**

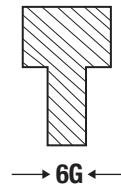
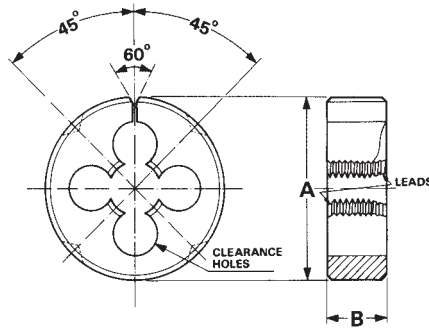

Unit : mm

Nominal Diameter	TPI	Outer Diameter	HSS	Carbon Steel	Thickness	No. Clearance Hole	Threading Diameter
ØD		A	EDP No.	EDP No.	B		
7/8"	9	2"	FBC0200245	FBB0200253	5/8"	5	22.14
1"	8	2"	FBC0200251	FBB0200257	5/8"	6	25.30
1.1/8"	7	2.1/4"	FBM2300001	FBM2300297	11/16"	6	
1.1/4"	7	2.1/4"	FBM2300004	FBM2300299	11/16"	6	
1.1/4"	7	2.1/2"	FBM2300005	FBM2300300	7/8"	6	
1.3/8"	6	2.1/2"	FBM2300010	FBM2300301	7/8"	6	
1.1/2"	6	2.1/2"	FBM2300012	FBM2300302	7/8"	6	
1.1/2"	6	3"	FBM2300013	FBM2300303	7/8"	6	
1.3/4"	5	4"	FBM2300014	FBM2300304	1"	6	
2"	4.5	4"	FBM2300015	FBM2300305	1"	6	



Round Split Dies

HSS TAPS

DIES

END MILLS

DRILLS

CARBIDE BURRS

CS TAPS

**BSF**

**Whitworth fine threads**

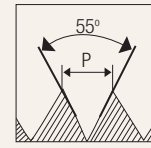

HSS

CS

BS  
1127

6G

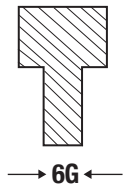
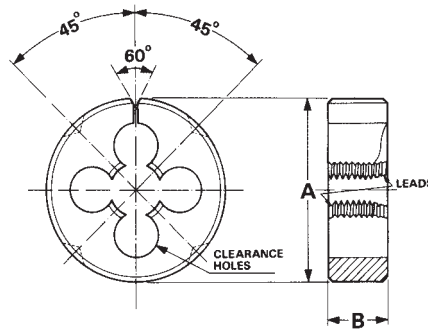

Unit : mm

Nominal Diameter ØD	TPI	Outer Diameter	HSS	Carbon Steel	Thickness B	No. Clearance Hole	Threading Diameter
		A	EDP No.	EDP No.			
3/16"	32	13/16"	FBC0200257	FBB0200261	1/4"	3	4.73
7/32"	28	13/16"	FBC0200263	FBB0200270	1/4"	4	5.51
1/4"	26	13/16"	FBC0200269	FBB0200279	1/4"	4	6.31
1/4"	26	1"	FBC0200275	FBB0200283	3/8"	4	6.31
9/32"	26	1"	FBC0200281	FBB0200299	3/8"	4	7.1
5/16"	22	1"	FBC0200287	FBB0200303	3/8"	4	7.89
3/8"	20	1"	FBC0200293	FBB0200320	3/8"	4	9.47
7/16"	18	1.1/2"	FBC0200314	FBB0200341	1/2"	4	11.05
1/2"	16	1.1/2"	FBC0200330	FBB0200349	1/2"	4	12.63
9/16"	16	1.1/2"	FBC0200336	FBB0200358	1/2"	5	14.22
5/8"	14	1.1/2"	FBC0200342	FBB0200366	1/2"	5	15.80
3/4"	12	1.1/2"	FBC0200353	FBB0200383	1/2"	5	18.97
7/8"	11	2"	FBC0200359	FBB0200391	5/8"	5	22.14
1"	10	2"	FBC0200365	FBB0200395	5/8"	6	25.30
1.1/8"	9	2.1/4"	FBM2300016	FBM2300306	11/16"	6	





Round Split Dies

**BSF**

**Whitworth fine threads**

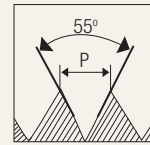

HSS CS **BS 1127** 6G

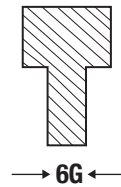
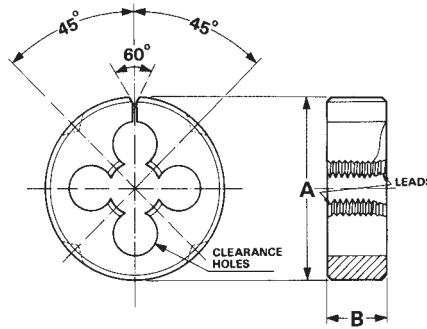

Unit : mm

Nominal Diameter ØD	TPI	Outer Diameter	HSS	Carbon Steel	Thickness B	No. Clearance Hole	Threading Diameter
		A	EDP No.	EDP No.			
1.1/4"	9	2.1/4"	FBM2300020	FBM2300308	11/16"	6	
1.3/8"	8	2.1/2"	FBM2300025	FBM2300310	7/8"	6	
1.1/2"	8	2.1/2"	FBM2300027	FBM2300311	7/8"	6	
1.1/2"	8	3"	FBM2300028	FBM2300312	7/8"	6	
1.3/4"	7	4"	FBM2300029	FBM2300313	1"	6	
2"	7	4"	FBM2300030	-	1"	6	

HSS TAPS

DIES

END MILLS

DRILLS

CARBIDE BURRS

CS TAPS



Round Split Dies

HSS TAPS

DIES

END MILLS

DRILLS

CARBIDE BURRS

CS TAPS

BA

British association threads

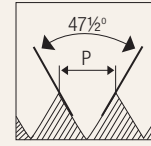

HSS

CS

BS 1127

6G

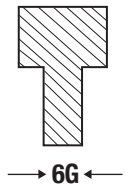
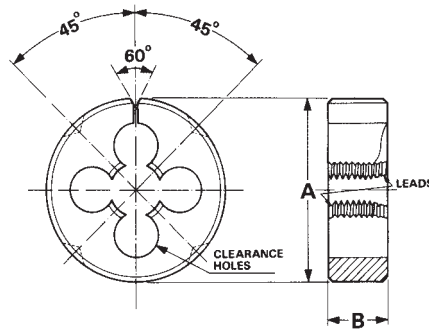

Unit : mm

Nominal Diameter ØD	TPI	Outer Diameter A	HSS	Carbon Steel	Thickness B	No. Clearance Hole	Threading Diameter
			EDP No.	EDP No.			
# 12	90.9	13/16"	FBC0202220	FBB0202153	1/4"	3	1.27
# 11	81.9	13/16"	FBC0202226	FBB0202158	1/4"	3	1.47
# 10	72.6	13/16"	FBC0202232	FBB0202163	1/4"	3	1.67
# 9	65.1	13/16"	FBC0202238	FBB0202168	1/4"	3	1.87
# 8	59.1	13/16"	FBC0202244	FBB0202173	1/4"	3	2.16
# 7	52.9	13/16"	FBC0202250	FBB0202178	1/4"	3	2.46
# 6	47.9	13/16"	FBC0202256	FBB0202183	1/4"	3	2.76
# 5	43	13/16"	FBC0202262	FBB0202188	1/4"	3	3.15
# 4	38.5	13/16"	FBC0202268	FBB0202193	1/4"	3	3.55
# 3	34.8	13/16"	FBC0202274	FBB0202198	1/4"	3	4.04
# 2	31.4	13/16"	FBC0202280	FBB0202203	1/4"	3	4.64
# 1	28.2	13/16"	FBC0202286	FBB0202208	1/4"	4	5.23
# 0	25.4	13/16"	FBC0202292	FBB0202213	1/4"	4	5.92



Round Split Dies

**BSB**

**British brass threads**

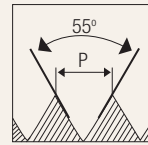

**HSS** **CS** **BS 1127** **6G**

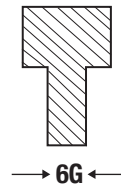
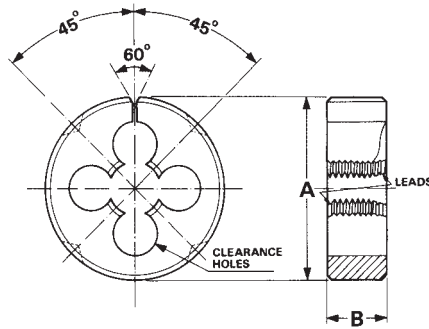

Unit : mm

Nominal Diameter ØD	TPI	Outer Diameter A	HSS	Carbon Steel	Thickness B	No. Clearance Hole	Threading Diameter
			EDP No.	EDP No.			
1/4"	26	13/16"	FBC0200371	FBB0200399	1/4"	4	6.31
1/4"	26	1"	FBC0200377	FBB0200403	3/8"	4	6.31
5/16"	26	1"	FBC0200383	FBB0200416	3/8"	4	7.89
3/8"	26	1"	FBC0200389	FBB0200425	3/8"	4	9.48
7/16"	26	1.1/2"	FBC0200395	FBB0200442	1/2"	5	11.06
1/2"	26	1.1/2"	FBC0200401	FBB0200455	1/2"	5	12.64
9/16"	26	1.1/2"	FBC0200407	FBB0200468	1/2"	5	14.23
5/8"	26	1.1/2"	FBC0200413	FBB0200476	1/2"	5	15.81
3/4"	26	1.1/2"	FBC0200419	FBB0200485	1/2"	6	18.98

HSS TAPS

DIES

END MILLS

DRILLS

CARBIDE BURRS

CS TAPS



Round Split Dies

HSS TAPS

DIES

END MILLS

DRILLS

CARBIDE BURRS

CS TAPS

ME

Model engineer threads

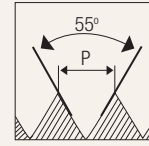

HSS CS BS 1127 6G

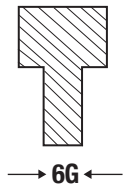
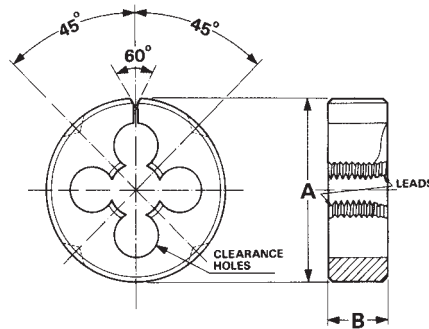

Unit : mm

Nominal Diameter ØD	TPI	Outer Diameter A	HSS	Carbon Steel	Thickness B	No. Clearance Hole	Threading Diameter
			EDP No.	EDP No.			
1/8"	40	13/16"	FBC0200906	FBB0200888	1/4"	3	3.14
5/32"	32	13/16"	FBC0200912	FBB0200892	1/4"	3	3.93
3/16"	40	13/16"	FBC0200918	FBB0200897	1/4"	3	4.72
7/32"	40	13/16"	FBC0200924	FBB0200902	1/4"	4	5.51
1/4"	40	13/16"	FBC0200930	FBB0200911	1/4"	4	6.31
1/4"	40	1"	FBC0202482	FBB0200916	3/8"	4	6.31
9/32"	32	1"	FBC0200936	FBB0200928	3/8"	4	7.10
5/16"	32	1"	FBC0200948	FBB0200946	3/8"	4	7.90
3/8"	32	1"	FBC0200954	FBB0200953	3/8"	4	9.48

WF

Whitworth fine special threads

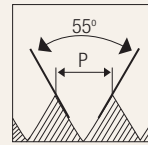

HSS CS BS 1127 6G

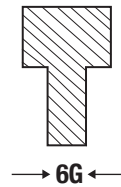
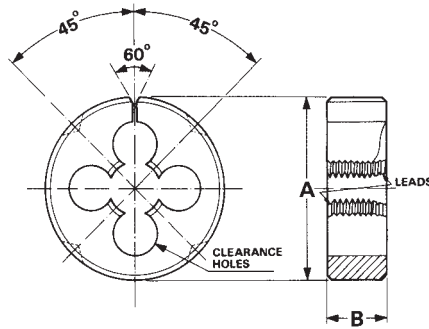

Unit : mm

Nominal Diameter ØD	TPI	Outer Diameter	HSS	Carbon Steel	Thickness	No. Clearance Hole	Threading Diameter
		A	EDP No.	EDP No.	B		
11/64"	40	13/16"	FBC0201032	FBB0201035	1/4"	3	4.33
3/16"	28	13/16"	FBC0201050	FBB0201045	1/4"	3	4.73
13/64"	24	13/16"	FBC0201038	FBB0201054	1/4"	3	5.13
15/64"	28	13/16"	FBC0201044	FBB0201068	1/4"	4	5.92
1/4"	32	1"	—	FBB0201083	3/8"	4	6.31
9/32"	40	1"	—	FBB0201087	3/8"	4	7.11
5/16"	40	1"	—	FBB0201091	3/8"	4	7.9
3/8"	40	1"	—	FBB0201095	3/8"	4	9.48
7/16"	40	1.1/2"	—	FBB0201107	1/2"	5	11.07
1/2"	40	1.1/2"	—	FBB0201131	1/2"	5	12.64



Round Split Dies

HSS TAPS

DIES

END MILLS

DRILLS

CARBIDE BURRS

CS TAPS

BSP

British standard pipe threads

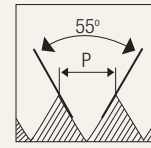

HSS

CS

BS  
1127

6G

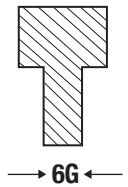
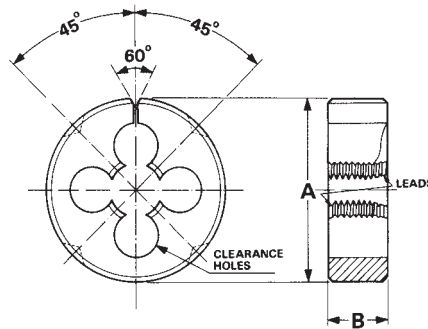

Unit : mm

Nominal Diameter ØD	TPI	Outer Diameter A	HSS	Carbon Steel	Thickness B	No. Clearance Hole	Threading Diameter
			EDP No.	EDP No.			
1/8"	28	1"	FBC0202117	FBB0202071	3/8"	4	9.68
1/4"	19	1.1/2"	FBC0202138	FBB0202088	1/2"	5	13.11
3/8"	19	1.1/2"	FBC0202149	FBB0202097	1/2"	5	16.6
1/2"	14	1.1/2"	FBC0202160	FBB0202106	1/2"	6	20.89
1/2"	14	2"	FBC0202166	FBB0202111	5/8"	5	20.89
5/8"	14	2"	FBC0202172	FBB0202116	5/8"	6	22.84
3/4"	14	2"	FBC0202178	FBB0202120	5/8"	6	26.36
7/8"	14	2"	FBC0202184	FBB0202125	5/8"	6+6	30.11
1"	11	2"	FBC0202190	FBB0202129	5/8"	6+6	33.16
1.1/8"	11	2.1/2"	FBM2300139	FBM2300426	7/8"	6	
1.1/4"	11	2.1/2"	FBM2300140	FBM2300427	7/8"	6	
1.1/4"	11	3"	FBM2300141	FBM2300428	7/8"	6	
1.3/8"	11	4"	FBM2300142	FBM2300430	1"		
1.1/2"	11	4"	FBM2300144	FBM2300431	1"	6	
1.3/4"	11	4"	FBM2300145	FBM2300432	1"		
2"	11	4"	FBM2300146	FBM2300433	1"	6	



Round Split Dies

**BSPT**

**British standard taper pipe threads**

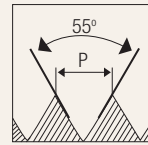

HSS
CS
BS 1127
6G

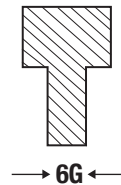
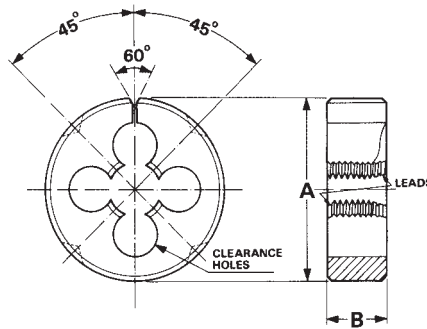

Unit : mm

Nominal Diameter ØD	TPI	Outer Diameter	HSS	Carbon Steel	Thickness B	No. Clearance Hole	Threading Diameter
		A	EDP No.	EDP No.			
1/8"	28	1"	FBM2300147	FBM2300434	10	4	
1/8"	28	1.1/2"	FBM2300148	FBM2300435	10	4	
1/4"	19	1.1/2"	FBM2300149	FBM2300437	14	4	
3/8"	19	1.1/2"	FBM2300150	FBM2300439	14	5	
3/8"	19	2"	FBM2300151	FBM2300440	14	5	
1/2"	14	2"	FBM2300152	FBM2300441	19	5	
3/4"	14	2"	FBM2300153	FBM2300442	20	6	
3/4"	14	2.1/2"	FBM2300154	FBM2300443	22	6	
1"	11	2.1/2"	FBM2300156	FBM2300444	25	6	
1"	11	3"	FBM2300157	FBM2300445	25	6	
1.1/4"	11	3"	FBM2300159	FBM2300446	25	6	
1.1/2"	11	4"	FBM2300160	FBM2300447	25	6	
2"	11	4"	FBM2300161	FBM2300448	27	6	

HSS TAPS

DIES

END MILLS

DRILLS

CARBIDE BURRS

CS TAPS



Round Split Dies

HSS TAPS

DIES

END MILLS

DRILLS

CARBIDE BURRS

CS TAPS

UNC

Unified coarse threads

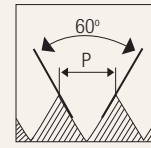

HSS CS BS 1127 2A

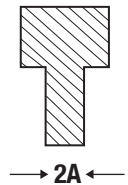
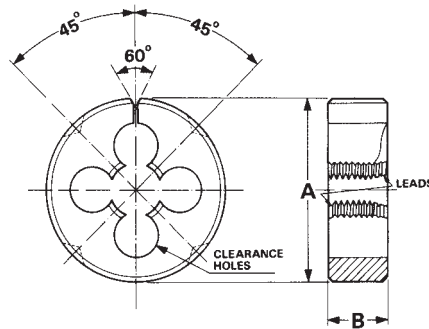

Unit : mm

Nominal Diameter ØD	TPI	Outer Diameter A	HSS	Carbon Steel	Thickness B	No. Clearance Hole	Threading Diameter
			EDP No.	EDP No.			
# 4	40	13/16"	FBC0200682	FBB0200706	1/4"	3	2.83
# 5	40	13/16"	FBC0200688	FBB0200714	1/4"	3	3.15
# 6	32	13/16"	FBC0200704	FBB0200722	1/4"	3	3.48
# 8	32	13/16"	FBC0200715	FBB0200730	1/4"	3	4.14
# 10	24	13/16"	FBC0200726	FBB0200738	1/4"	3	4.79
# 12	24	13/16"	FBC0200742	FBB0200750	1/4"	4	5.45
1/4"	20	13/16"	FBC0200747	FBB0200758	1/4"	4	6.31
1/4"	20	1"	FBC0200753	FBB0200766	3/8"	4	6.31
5/16"	18	1"	FBC0200769	FBB0200782	3/8"	4	7.89
3/8"	16	1"	FBC0200791	FBB0200799	3/8"	4	9.47
7/16"	14	1.1/2"	FBC0200817	FBB0200824	1/2"	4	11.05
1/2"	13	1.1/2"	FBC0200843	FBB0200840	1/2"	4	12.62
9/16"	12	1.1/2"	FBC0200859	FBB0200852	1/2"	5	14.21
5/8"	11	1.1/2"	FBC0200865	FBB0200860	1/2"	5	15.79
3/4"	10	1.1/2"	FBC0200882	FBB0200872	1/2"	6	18.96





Round Split Dies

**UNC**

**Unified coarse threads**

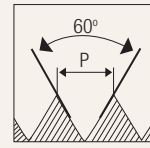

HSS
CS
BS 1127
2A

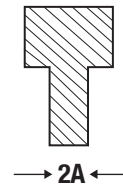
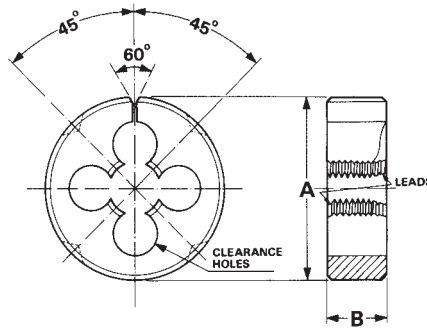

Unit : mm

Nominal Diameter ØD	TPI	Outer Diameter	HSS	Carbon Steel	Thickness	No. Clearance Hole	Threading Diameter
		A	EDP No.	EDP No.	B		
7/8"	9	2"	FBC0200894	FBB0200880	5/8"	5	22.14
1"	8	2"	FBC0200900	FBB0200884	5/8"	6	25.3
1.1/8"	7	2.1/4"	FBM2300048	FBM2300322	11/16"	6	
1.1/4"	7	2.1/4"	FBM2300050	FBM2300325	11/16"	6	
1.3/8"	6	2.1/2"	FBM2300054	FBM2300327	7/8"	6	
1.1/2"	6	2.1/2"	FBM2300056	FBM2300329	7/8"	6	
1.1/2"	6	3"	FBM2300057	FBM3000530	7/8"	6	
1.3/4"	5	4"	FBM2300058	FBM2300330	1"	8	
2"	4.5	4"	FBM2300059	FBM2300331	1"	6	

HSS TAPS

DIES

END MILLS

DRILLS

CARBIDE BURRS

CS TAPS



Round Split Dies

HSS TAPS

DIES

END MILLS

DRILLS

CARBIDE BURRS

CS TAPS

UNF

Unified fine threads

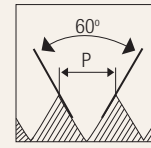

HSS
CS
BS 1127
2A

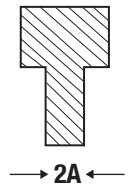
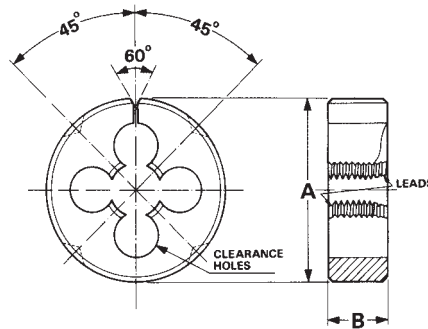

Unit : mm

Nominal Diameter ØD	TPI	Outer Diameter A	HSS	Carbon Steel	Thickness B	No. Clearance Hole	Threading Diameter
			EDP No.	EDP No.			
# 3	56	13/16"	FBC0200437	FBB0200498	1/4"	3	
# 4	48	13/16"	FBC0200443	FBB0200502	1/4"	3	2.83
# 5	44	13/16"	FBC0200449	FBB0200506	1/4"	3	3.16
# 6	40	13/16"	FBC0200465	FBB0200514	1/4"	3	3.48
# 8	36	13/16"	FBC0200476	FBB0200522	1/4"	3	4.14
# 10	32	13/16"	FBC0200487	FBB0200530	1/4"	3	4.8
# 12	28	13/16"	FBC0200498	FBB0200542	1/4"	4	5.46
1/4"	28	13/16"	FBC0200515	FBB0200550	1/4"	4	6.32
1/4"	28	1"	FBC0200527	FBB0200558	3/8"	4	6.32
5/16"	24	1"	FBC0200538	FBB0200578	3/8"	4	7.9
3/8"	24	1"	FBC0200560	FBB0200599	3/8"	4	9.48
7/16"	20	1.1/2"	FBC0200586	FBB0200627	1/2"	4	11.06
1/2"	20	1.1/2"	FBC0200607	FBB0200647	1/2"	5	12.65
9/16"	18	1.1/2"	FBC0200618	FBB0200660	1/2"	5	14.23
5/8"	18	1.1/2"	FBC0200629	FBB0200669	1/2"	5	15.82
3/4"	16	1.1/2"	FBC0200646	FBB0200682	1/2"	6	18.99



Round Split Dies

UNF

Unified fine threads

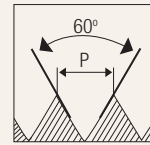

HSS

CS

BS  
1127

2A

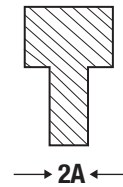
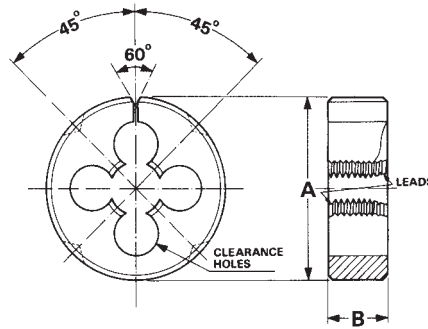

Unit : mm

Nominal Diameter	Pitch	Outer Diameter	HSS	Carbon Steel	Thickness	No. Clearance Hole	Threading Diameter
ØD	TPI	A	EDP No.	EDP No.	B		
7/8"	14	2"	FBC0200658	FBB0200690	5/8"	5	22.13
1"	12	2"	FBC0200664	FBB0200694	5/8"	6	25.31
1.1/8"	12	2.1/4"	FBM2300034	FBM2300314	11/16"	6	
1.1/4"	12	2.1/4"	FBM2300037	FBM2300317	11/16"	6	
1.3/8"	12	2.1/2"	FBM2300041	-	7/8"	6	
1.1/2"	12	2.1/2"	FBM2300043	FBM2300319	7/8"	6	
1.1/2"	12	3"	FBM2300044	FBM2300320	7/8"	6	
1.3/4"	14	4"	FBM2300046	FBM2300647	1"	6	
2"	-	4"	FBM2300047	FBM2300321	1"	6	

HSS TAPS

DIES

END MILLS

DRILLS

CARBIDE BURRS

CS TAPS



Round Split Dies

HSS TAPS

DIES

END MILLS

DRILLS

CARBIDE BURRS

CS TAPS

NPT

## National taper pipe threads

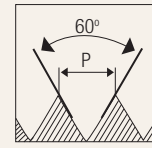

HSS

CS

BS  
1127

6G

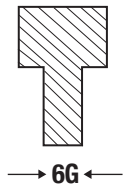
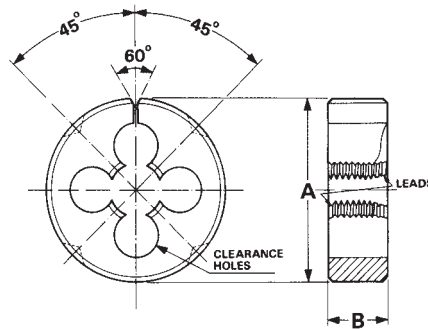

Unit : mm

Nominal Diameter ØD	TPI	Outer Diameter A	HSS	Carbon Steel	Thickness B	No. Clearance Hole	Threading Diameter
			EDP No.	EDP No.			
1/8"	27	1"	FBM2300162	FBM2300449	10	4	
1/8"	27	1.1/2"	FBM2300163	FBM2300450	10	4	
1/4"	18	1.1/2"	FBM2300164	FBM2300453	15	4	
3/8"	18	1.1/2"	FBM2300165	FBM2300456	15	5	
3/8"	18	2"	FBM2300166	FBM2300457	14	5	
1/2"	14	2"	FBM2300167	FBM2300459	19	5	
3/4"	14	2"	FBM2300168	FBM2300461	20	6	
3/4"	14	2.1/2"	FBM2300169	FBM2300462	22	6	
1"	11.1/2	2.1/2"	FBM2300171	FBM2300464	25	6	
1"	11.1/2	3"	FBM2300172	FBM2300465	25	6	
1.1/4"	11.1/2	3"	FBM2300173	FBM2300467	25	6	
1.1/2"	11.1/2	4"	FBM2300174	FBM2300468	25	6	
2"	11.1/2	4"	FBM2300175	FBM2300469	27	6	