

おかげさまで
100th
PEACOCK

SINCE 1916

PEACOCK®

PRECISION MEASURING INSTRUMENTS



MODEL 107 IS JAPAN'S DOMESTICALLY DIAL GAUGE.

*WIDELY USED IN
MANUFACTURING PLANTS*

≡≡≡ SINCE 1916 ≡≡≡
PEACOCK®
TOKYO, JAPAN

Mission Statement

Harmony and Progress

ORIGIN of PEACOCK

The reliable PEACOCK brand is highly acclaimed as being representative of Japan's DIAL GAUGES.

The name originates from a haiku poem by Shiki Masaoka that goes,

“Fanning out its tail in the Spring breeze, see-PEACOCK!”

Founder Kiyonobu Ozaki had been interested in haiku since the upper grades of primary school, and he established this trademark for the brand inspired by the neat image Shiki's poem invoked.

Manufacturing fine products that resemble the subtle pattern on the tail of PEACOCK has enable the company to contribute to society.



ISO 9001 Certified OZAKI MFG. CO., LTD.

We, OZAKI MFG. CO., LTD., received ISO 9001 certification in 1999 and now renewed 2015 edition. We have been supplying high quality measuring instruments with reliable brand "PEACOCK" to our customers not only Japan but also overseas countries.

Management System Certificate



Appendix

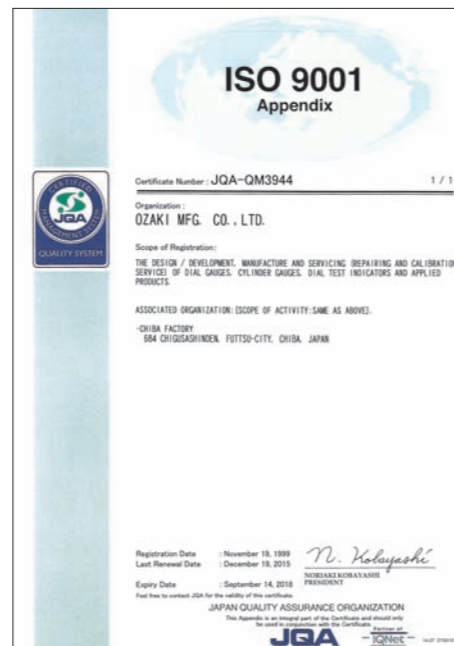

COPY

ISO Certification for
DIAL GAUGES, PIC TEST INDICATORS, CYLINDER GAUGES AND
ITS APPLIED DIAL GAUGES.



Contents

0	Quick Chart	14 ~ 20	
1	Dial Gauges	21 ~ 44	
2	Lever Type Dial Indicators	45 ~ 60	
3	Cylinder Gauges	61 ~ 68	
4	Inch Scale Dial Indicators	69 ~ 76	
5	Gauge Testers	77 ~ 81	
6	Thickness Gauges	83 ~ 96	
7	Dial Caliper Gauges	97 ~ 104	
8	Applied Dial Gauges	105 ~ 113	
9	Stands	115 ~ 119	
10	Signal Indicators	121 ~ 128	
11	Digital Indicators	129 ~ 156	
12	Parts Drawings	157 ~ 169	

0 Quick Chart

- Weight of our products14
- for Dial Gauge15
- for Lever Type Dial Indicator16-17
- for Cylinder Gauge18-20



1 Dial Gauges

- One Revolution Dial Gauges "Z" Series22-23
- Standard Dial Gauges 0.001, 0.005mm type24-25
- Standard Dial Gauges 0.01mm type26-27
- Long Travel Dial Gauges28-29
- Miniature Dial Gauges30
- Back Plunger Dial Gauges31
- Replaceable Contact Points32-35
- Outer Dimensions36-37
- Accessories38-39
- Outer Dial Plates38
- Backs40
- Repair tools41
- Technical Data42-43
- Marking Service44



2 Lever Type Dial Indicators

- Without Change Lever "PCN" series46-47
- Double Dial Face "W" series47
- One Revolution New Pic Test48-49
- Low Measuring Force "E" series50
- Anti-Magnetic & Non-Electrifying "U" series51
- Large Dial Face "D" series52
- With Change Lever "PC" series53
- With Ruby ball "R" series54
- With Dovetail Stem "DS8V" series55
- Accessories (Option)56
- Replaceable Contact Points57
- Outer Dimensions58
- Applied Examples59
- Precautions for Handling59
- Without Stem "V" series60
- Right Angle Contact Point for Pic Test60



3 Cylinder Gauges

- Standard "CC" series62
- Special Length below grip "CC" type62
- Short size "S" series63
- Standard "CG" series (Blind hole type)64
- Special Length below grip "CG" type64
- Dimensions for Feelers and Washers for Cylinder Gauges65
- "R" series Cylinder Gauges66-68

4 Inch Scale Dial Indicators

- Dial Gages 0.001" type70-71
- Dial Gages 0.0001" type71
- Metric Graduations 0.01mm72
- Pic Test Indicators73-74
- Dial Bore Gage Sets75
- Dial Thickness Gage76

5 Gauge Testers

- Dial Gauge Tester80
- Cylinder Gauge Tester81

6 Thickness Gauges

- Dial Thickness Gauge 0.01mm type84-85
- Dial Thickness Gauge 0.001mm type86
- Dial Swift Gauge86
- Pearl Scale87
- Snap Calipers87
- Large type Dial Thickness Gauges88
- Roller type Dial Thickness Gauge88
- Dial Sheet Gauges89
- Dial Pipe Gauges90
- Dial Lens Gauge90
- Dial Thickness Gauge Special Order91
- Dial Upright Gauges92
- Constant Pressure Thickness Gauges
"FFG" "FFA" "FFD" series93-96



7 Dial Caliper Gauges

- Outside "LA" series98-101
- Inside "LB" series102-103
- Applied examples104



8 Applied Dial Gauges

- Dial Depth Gauges "T" series106-107
- Digital Depth Gauges "T" series108-109
- Dial Inside Gauges "U" series110
- Dial Hole Gauge111
- Digital Hole Gauge111
- Lever type Contact Point "XY" series112
- Angle Contact Point "XZ" series112
- Bench Center113



9 Stands

- Dial Gauge Stands116-117
- Magnetic Stands118
- Magnetic Holder119



10 Signal Indicators

- Signal Gauge 0.001, 0.01, 0.05mm type.....122
- Signal Checker122
- Signal Box124
- Signal Gauge Set-Up126
- Connection Diagram127
- Example of Use128



11 Digital Indicators

- Digital Gauges(Cordless type)132-133
- Digital Gauges (Integrated Display type)134-135
- Linear Gauges 2, 5mm range136-137
- Linear Gauges 10, 20mm range138-139
- Linear Gauge Rectangular wave out put type138-139
- Linear Gauges 50, 100mm range140-141
- Linear Gauges 0.1μm. 0.5μm resolution142
- Digital Counters Compact type144-145
- Digital Counter with High Resolution146
- Digital Counter with Judging Function147
- Digital Indicator Application Series149-151
- Deep Hole Bore Gauges152-153
- Outer Dimensions154
- Technical Glossary155-156



12 Parts Drawings

- PCN · PC series158-161
- Dial Gauges · Thickness Gauges · Lens Gauge.....162-165
- Cylinder Gauges166-169

INDEX (Alphabetical)

Model No.	Description	Page
C		
CCT-2	Cylinder Gauge Tester	81
CC-02	Cylinder Gauge	62
CC-01	Cylinder Gauge	62
CC-1	Cylinder Gauge	62
CC-2	Cylinder Gauge	62
CC-3	Cylinder Gauge	62
CC-3C	Cylinder Gauge	62
CC-4	Cylinder Gauge	62
CC-5	Cylinder Gauge	62
CC-6	Cylinder Gauge	62
CC-1S	Short size Cylinder Gauge	63
CC-2S	Short size Cylinder Gauge	63
CC-3S	Short size Cylinder Gauge	63
CC-3CS	Short size Cylinder Gauge	63
CC-01R	Cylinder Gauge	66
CC-1R	Cylinder Gauge	66
CC-2R	Cylinder Gauge	66
CC-3R	Cylinder Gauge	66
CC-3CR	Cylinder Gauge	66
CG-01	Cylinder Gauge (Blind Hole Type)	64
CG-1	Cylinder Gauge (Blind Hole Type)	64
CG-2	Cylinder Gauge (Blind Hole Type)	64
CG-3	Cylinder Gauge (Blind Hole Type)	64
CG-3C	Cylinder Gauge (Blind Hole Type)	64
CG-4	Cylinder Gauge (Blind Hole Type)	64
CG-5	Cylinder Gauge (Blind Hole Type)	64
CG-6	Cylinder Gauge (Blind Hole Type)	64
CG-01R	Cylinder Gauge	66
CG-1R	Cylinder Gauge	66
CG-2R	Cylinder Gauge	66
CG-3R	Cylinder Gauge	66
CG-3CR	Cylinder Gauge	66
C-500	Digital Counter	145
C-700	Digital Counter	145
C-7HS	Digital Counter	146
CM-5B	Digital Counter	147

Model No.	Description	Page
D		
DL-2	Linear Gauge	136
D-5	Linear Gauge	136
D-5B	Linear Gauge	152
D-5UZ	Linear Gauge	136
D-10	Linear Gauge	138
D-20	Linear Gauge	138
D-50	Linear Gauge	140
D-100	Linear Gauge	140
DN-10	Linear Gauge	138
DN-10S	Linear Gauge	138
DN-20	Linear Gauge	138
DN-20S	Linear Gauge	138
DL-2S	Linear Gauge	136
D-5S	Linear Gauge	136
D-5SB	Linear Gauge	152
D-10S	Linear Gauge	138
D-10SS	Linear Gauge	142
D-10HS	Linear Gauge	142
D-20S	Linear Gauge	138
D-50S	Linear Gauge	140
D-100S	Linear Gauge	140
DG-127	Digital Gauge	132
DG-205	Digital Gauge	132
DG-257	Digital Gauge	132
E		
EG-1	Snap Caliper	87
EG-2	Snap Caliper	87
EMCC-2	Deep Hole Bore Gauge	152
EMCC-3	Deep Hole Bore Gauge	152
EMCC-4	Deep Hole Bore Gauge	152
EMCC-5	Deep Hole Bore Gauge	152
EMCC-6	Deep Hole Bore Gauge	152
F		
FFA-1	Constant Pressure Thickness Gauge	94

Model No.	Description	Page
FFA-2	Constant Pressure Thickness Gauge	94
FFA-3	Constant Pressure Thickness Gauge	94
FFA-4	Constant Pressure Thickness Gauge	94
FFA-5	Constant Pressure Thickness Gauge	94
FFA-6	Constant Pressure Thickness Gauge	94
FFA-7	Constant Pressure Thickness Gauge	94
FFA-8	Constant Pressure Thickness Gauge	94
FFA-9	Constant Pressure Thickness Gauge	94
FFA-10	Constant Pressure Thickness Gauge	94
FFA-11	Constant Pressure Thickness Gauge	94
FFA-12	Constant Pressure Thickness Gauge	94
FFA-13	Constant Pressure Thickness Gauge	94
FFD-1	Constant Pressure Thickness Gauge	95
FFD-2	Constant Pressure Thickness Gauge	95
FFD-3	Constant Pressure Thickness Gauge	95
FFD-4	Constant Pressure Thickness Gauge	95
FFD-6	Constant Pressure Thickness Gauge	95
FFD-7	Constant Pressure Thickness Gauge	95
FFD-8	Constant Pressure Thickness Gauge	95
FFD-10	Constant Pressure Thickness Gauge	95
FFD-13	Constant Pressure Thickness Gauge	95
FFG-1	Constant Pressure Thickness Gauge	93
FFG-2	Constant Pressure Thickness Gauge	93
FFG-4	Constant Pressure Thickness Gauge	93
FFG-5	Constant Pressure Thickness Gauge	93
FFG-6	Constant Pressure Thickness Gauge	93
FFG-7	Constant Pressure Thickness Gauge	93
FFG-8	Constant Pressure Thickness Gauge	93
FFG-9	Constant Pressure Thickness Gauge	93
FFG-11	Constant Pressure Thickness Gauge	93
FFG-12	Constant Pressure Thickness Gauge	93
G		
G	Dial Thickness Gauge	85
G-1A	Dial Thickness Gauge	85
G-1M	Dial Thickness Gauge	85
G-2	Dial Thickness Gauge	85
G-2.4N	Dial Thickness Gauge	85
G2-205	Digital Thickness Gauge	149
G2-205A	Digital Thickness Gauge	149

Model No.	Description	Page
G2-205M	Digital Thickness Gauge	149
G2-257	Digital Thickness Gauge	149
G2-257A	Digital Thickness Gauge	149
G2-257M	Digital Thickness Gauge	149
G-3	Dial Thickness Gauge	85
G-4	Dial Thickness Gauge	85
G-6C	Dial Thickness Gauge	86
G-7C	Dial Thickness Gauge	86
G-20	Dial Thickness Gauge	85
G-30	Dial Thickness Gauge	85
GL	Dial Lens Gauge	90
GH-1	Dial Hole Gauge	111
GH-127	Digital Hole Gauge	111
G-MT	Dial Thickness Gauge	85
H		
H	Dial Thickness Gauge	85
H-0.4N	Dial Thickness Gauge	85
H-2.4N	Dial Thickness Gauge	85
H-1A	Dial Thickness Gauge	85
H-2	Dial Thickness Gauge	85
H-3	Dial Thickness Gauge	85
H-20	Dial Thickness Gauge	85
H-30	Dial Thickness Gauge	85
H-MT	Dial Thickness Gauge	85
HR-1	Dial Thickness Gauge Roller Type	88
J		
J-A	Dial Thickness Gauge	88
JA-205	Digital Thickness Gauge	150
JA-257	Digital Thickness Gauge	150
J-B	Dial Thickness Gauge	88
K		
K-1	Dial Sheet Gauge	89
K1-257	Digital Sheet Gauge	150
K-2	Dial Sheet Gauge	89

Model No.	Description	Page
K-3	Dial Sheet Gauge	89
K-4	Dial Sheet Gauge	89
K-7	Dial Sheet Gauge	89

L

LA-1	Outside Dial Caliper Gauge	99
LA-2	Outside Dial Caliper Gauge	99
LA-3	Outside Dial Caliper Gauge	99
LA-4	Outside Dial Caliper Gauge	99
LA-5	Outside Dial Caliper Gauge	99
LA-5S	Outside Dial Caliper Gauge	99
LA-6	Outside Dial Caliper Gauge	99
LA-7	Outside Dial Caliper Gauge	99
LA-8	Outside Dial Caliper Gauge	99
LA-9	Outside Dial Caliper Gauge	99
LA-10	Outside Dial Caliper Gauge	99
LA-11	Outside Dial Caliper Gauge	101
LA-13	Outside Dial Caliper Gauge	101
LA-14	Outside Dial Caliper Gauge	101
LA-20	Outside Dial Caliper Gauge	101
LA-21	Outside Dial Caliper Gauge	101
LA-22	Outside Dial Caliper Gauge	101
LA-23	Outside Dial Caliper Gauge	101
LA-24	Outside Dial Caliper Gauge	101
LA-31	Outside Dial Caliper Gauge	101
LB-1	Inside Dial Caliper Gauge	103
LB-2	Inside Dial Caliper Gauge	103
LB-3	Inside Dial Caliper Gauge	103
LB-4	Inside Dial Caliper Gauge	103
LB-5	Inside Dial Caliper Gauge	103
LB-6	Inside Dial Caliper Gauge	103
LB-7	Inside Dial Caliper Gauge	103
LB-7S	Inside Dial Caliper Gauge	103
LB-7V	Inside Dial Caliper Gauge	103
LB-8	Inside Dial Caliper Gauge	103
LB-9	Inside Dial Caliper Gauge	103
LB-14	Inside Dial Caliper Gauge	103
LH-2	Inside Dial Caliper Gauge	103

Model No.	Description	Page
N		
NB	Dial Gauge Tester	80

O

OA	Bench Center	113
-----------	--------------------	------------

P

P-1	Dial Pipe Gauge	90
P-2	Dial Pipe Gauge	90
P-3	Dial Pipe Gauge	90
P2-127	Digital Pipe Gauge	150
P2-257	Digital Pipe Gauge	150
PC-1A	Pic Test Indicator	53
PC-1AE	Pic Test Indicator	50
PC-1AR	Pic Test Indicator	54
PC-1B	Pic Test Indicator	53
PC-1BE	Pic Test Indicator	50
PC-1BR	Pic Test Indicator	54
PC-1BW	Pic Test Indicator	47
PC-1L	Pic Test Indicator	53
PC-1LE	Pic Test Indicator	50
PC-1LR	Pic Test Indicator	54
PC-2	Pic Test Indicator	53
PC-2R	Pic Test Indicator	54
PC-3	Pic Test Indicator	53
PC-3L	Pic Test Indicator	53
PC-4	Pic Test Indicator	53
PCN-0	Pic Test Indicator	47
PCN-1A	Pic Test Indicator	47
PCN-1AE	Pic Test Indicator	50
PCN-1AR	Pic Test Indicator	54
PCN-1AU	Pic Test Indicator	51
PCN-1B	Pic Test Indicator	47
PCN-1BE	Pic Test Indicator	50
PCN-1BR	Pic Test Indicator	54
PCN-1BU	Pic Test Indicator	51
PCN-1BZ(A)	One Revolution Pic Test Indicator	48

Model No.	Description	Page
PCN-1BZ(B)	One Revolution Pic Test Indicator	49
PCN-1L	Pic Test Indicator	47
PCN-1LE	Pic Test Indicator	50
PCN-1LR	Pic Test Indicator	54
PCN-1LU	Pic Test Indicator	51
PCN-1LZ(A)	One Revolution Pic Test Indicator	48
PCN-1LZ(B)	One Revolution Pic Test Indicator	49
PCN-2	Pic Test Indicator	47
PCN-2E	Pic Test Indicator	50
PCN-2R	Pic Test Indicator	54
PCN-2U	Pic Test Indicator	51
PCN-2Z(A)	One Revolution Pic Test Indicator	48
PCN-2Z(B)	One Revolution Pic Test Indicator	49
PCN-2B	Pic Test Indicator	47
PCN-2BR	Pic Test Indicator	54
PCN-2BU	Pic Test Indicator	51
PCN-S	Pic Test Indicator	47
PCN-SR	Pic Test Indicator	54
PCN-SU	Pic Test Indicator	51
PCN-5	Pic Test Indicator	47
PCN-5R	Pic Test Indicator	54
PCN-5U	Pic Test Indicator	51
PCN-6	Pic Test Indicator	47
PCN-6R	Pic Test Indicator	54
PCN-6S	Pic Test Indicator	47
PCN-6U	Pic Test Indicator	51
PCN-7A	Pic Test Indicator	47
PCN-7C	Pic Test Indicator	47
PCN-1AD	Pic Test Indicator	52
PCN-1LD	Pic Test Indicator	52
PCN-2BD	Pic Test Indicator	52
PCN-SD	Pic Test Indicator	52
PCD-2	Centricator	56
PCD-3	Centricator	56
PCD-4	Centricator	56
PDS-2	Dial Gauge Stand	117
PDS-2F	Dial Gauge Stand	117
PDN-21	Digital Gauge	134
PDN-51	Digital Gauge	134
PS-1	Pearl Scale	87

Model No.	Description	Page
Q		
Q-1	Dial Swift Gauge	86

R

R1-127	Digital Upright Gauge	151
R1-205	Digital Upright Gauge	151
R1-257	Digital Upright Gauge	151
R1-A	Dial Upright Gauge	92
R1-B	Dial Upright Gauge	92
R1-C	Dial Upright Gauge	92
Repair Tools	41

S

SIS-4F	Dial Gauge Stand	116
SIS-6C	Dial Gauge Stand	117
SIS-7	Dial Gauge Stand	117
S-5	Signal Gauge	122
S-7	Signal Gauge	122
S-9	Signal Gauge	122
SC-2A	Signal Checker	122
SB-3	Signal Box	124
Spare Parts	for Dial Gauge	32-35-40
	for Pic Test Indicator	56-57
	Parts Drawing	157-169

T

T-1	Dial Depth Gauge	106
T-2	Dial Depth Gauge	106
T-3	Dial Depth Gauge	106
T-4	Dial Depth Gauge	106
T-1W	Dial Depth Gauge	106
T-2W	Dial Depth Gauge	106
T-2B	Dial Depth Gauge	106
T-2C	Dial Depth Gauge	106
T-6A	Dial Depth Gauge	107
T-6B	Dial Depth Gauge	107
T1-127	Digital Depth Gauge	108

Model No.	Description	Page
T1-205	Digital Depth Gauge	108
T1-257	Digital Depth Gauge	108
T2-205W	Digital Depth Gauge	108
T2-257W	Digital Depth Gauge	108
T3-127	Digital Depth Gauge	108
T5-127	Digital Depth Gauge	108
T6-127	Digital Depth Gauge	108

U

U-1	Dial Inside Gauge	110
U2HA	Dial Inside Gauge	110
U2HB	Dial Inside Gauge	110
U2FA	Dial Inside Gauge	110
U2FB	Dial Inside Gauge	110
U3HA	Dial Inside Gauge	110
U3HB	Dial Inside Gauge	110

X

XY-1	Lever type Contact Point	112
XY-2	Lever type Contact Point	112
XZ-1	Angle Contact Point	112
XZ-2	Angle Contact Point	112

Y

YM-1	Magnetic Stand	118
YM-2	Magnetic Stand	118
YM-3	Magnetic Stand	118
YMH-1	Magnetic Holder	119

Model No.	Description	Page
(Numerical)		
1		
107	Dial Gauge	27
107-BL	Dial Gauge	27
107-DX	Dial Gauge	27
107-E	Dial Gauge	27
107-HG	Dial Gauge	27
107-LL	Dial Gauge	27
107-SWA	Dial Gauge	27
107F	Dial Gauge	27
107F-RE	Dial Gauge	27
107F-T	Dial Gauge	27
107W	Dial Gauge	27
107Z	One Revolution Dial Gauge	23
107Z-XB	One Revolution Dial Gauge	23
117Z	One Revolution Dial Gauge	23
1200	Inch Scale Dial Gauge	71
1201	Inch Scale Metric Graduation	72
1310	Inch Scale Dial Gauge	71
1310B	Inch Scale Dial Gauge	71
1311	Inch Scale Metric Graduation	72
1330	Inch Scale Dial Gauge	71
1330B	Inch Scale Dial Gauge	71
1331	Inch Scale Metric Graduation	72
1361	Inch Scale Metric Graduation	72
1364	Inch Scale Dial Gauge	71
1364B	Inch Scale Dial Gauge	71
1440	Inch Scale Dial Gauge	71
1440B	Inch Scale Dial Gauge	71
1460	Inch Scale Dial Gauge	71
1460B	Inch Scale Dial Gauge	71
147Z	One Revolution Dial Gauge	23
15DZ	One Revolution Dial Gauge	23
15Z	One Revolution Dial Gauge	23
15Z-SWF	One Revolution Dial Gauge	23
17	One Revolution Dial Gauge	27
17B	One Revolution Dial Gauge	23
17Z	One Revolution Dial Gauge	23
17Z-SWA	One Revolution Dial Gauge	23
18	One Revolution Dial Gauge	23
196A	Back Plunger Type Dial Gauge	31

Model No.	Description	Page
196A-6	Back Plunger Type Dial Gauge	31
196B	Back Plunger Type Dial Gauge	31
196B-T	Back Plunger Type Dial Gauge	31
196Z	One Revolution Dial Gauge	23-31

2

2000	Inch Scale Test Indicator	73
2000B	Inch Scale Test Indicator	73
2010	Inch Scale Test Indicator	73
2010B	Inch Scale Test Indicator	73
2030	Inch Scale Test Indicator	73
2030B	Inch Scale Test Indicator	73
2050	Inch Scale Test Indicator	74
2050B	Inch Scale Test Indicator	74
2060	Inch Scale Test Indicator	74
2060B	Inch Scale Test Indicator	74
207	Long Travel Dial Gauge	29
207F-PL	Long Travel Dial Gauge	29
207F-T	Long Travel Dial Gauge	29
207S	Long Travel Dial Gauge	29
207S-LL	Long Travel Dial Gauge	29
207W	Long Travel Dial Gauge	29
207WF-T	Long Travel Dial Gauge	29
2200	Inch Scale Test Indicator	74
2200B	Inch Scale Test Indicator	74
2210	Inch Scale Test Indicator	74
2210B	Inch Scale Test Indicator	74
25	Dial Gauge	25
25F-RE	Dial Gauge	25
25S	Dial Gauge	25

3

307	Long Travel Dial Gauge	29
307S	Long Travel Dial Gauge	29
36A	Miniature Dial Gauge	30
36B	Miniature Dial Gauge	30
36Z	One Revolution Dial Gauge	23

4

4600	Inch Scale Dial Thickness Gauge	76
47	Miniature Dial Gauge	30

Model No.	Description	Page
47F	Miniature Dial Gauge	30
47SZ	One Revolution Dial Gauge	23
47Z	One Revolution Dial Gauge	23
47Z-XB	One Revolution Dial Gauge	23

5

5-SWF	Dial Gauge	25
5-DX	Dial Gauge	25
507	Long Travel Dial Gauge	29
509	Long Travel Dial Gauge	29
55	Dial Gauge	25
55-DX	Dial Gauge	25
56	Dial Gauge	25
57	Dial Gauge	27
57-SWA	Dial Gauge	27
5710	Inch Scale Dial Bore Gage set	75
5710B	Inch Scale Dial Bore Gage set	75
5730	Inch Scale Dial Bore Gage set	75
5730B	Inch Scale Dial Bore Gage set	75
5740	Inch Scale Dial Bore Gage set	75
5740B	Inch Scale Dial Bore Gage set	75
5750	Inch Scale Dial Bore Gage set	75
5750B	Inch Scale Dial Bore Gage set	75
5770	Inch Scale Dial Bore Gage set	75
5770B	Inch Scale Dial Bore Gage set	75
5790	Inch Scale Dial Bore Gage set	75
5790B	Inch Scale Dial Bore Gage set	75
57B	Dial Gauge	27
57F	Dial Gauge	27
57S	Miniature Dial Gauge	30
5B	Dial Gauge	25
5B-HG	Dial Gauge	25
5F	Dial Gauge	25
5S	Miniature Dial Gauge	30
5Z	One Revolution Dial Gauge	23
5Z-XB	One Revolution Dial Gauge	23

8

809	Long Travel Dial Gauge	29
------------	------------------------------	-----------

Weight of our products (packed with case)

*All the Pic Test Indicators are approx. 150g

weight: approx grams.

Model	weight (g)	Model	weight (g)	Model	weight (g)	Model	weight (g)	Model	weight (g)
Dial Gauge		5Z	165	H-1A	280	Dial Caliper Gauge		Linear Gauge	
107	190	5Z-XB	165	H-0.4N	280	LA-1	820	D-5	270
107F	150	47Z	110	H-2.4N	280	LA-2	1,250	D-5UZ	250
107-BL	190	47Z-XB	110	H-20	295	LA-3	2,100	D-5B	520
107F-RE	170	47SZ	100	H-30	315	LA-4	850	D-10	340
107W	220	147Z	100	H-2	780	LA-5	950	D-20	400
107-SWA	205	15Z	165	H-3	780	LA-5S	900	D-50	700
107-T	190	15Z-SWF	165	HR-1	550	LA-6	750	D-50HT	700
107F-T	150	15DZ	250	J-A	1,600	LA-8	1,060	D-50WA	720
107-LL	195	18	200	J-B	1,300	LA-9	770	D-100	900
107F-LL	155	196Z	110	PG-10	165	LA-10	1,000	D-100WA	920
107-E	190	36Z	165	GL	220	LA-11	780	DN-10	340
107-DX	220	Cylinder Gauge		P-1	200	LA-13	1,800	DN-20	400
107-HG	190	CC-02	370	P-2	330	LA-20	760	D-5S	270
57	190	CC-01	390	P-3	350	LA-21	1,050	D-5SB	520
57F	150	CC-1	680	Q-1	270	LA-22	1,280	D-10S	340
57B	150	CC-2	680	EG-1	130	LA-23	1,330	D-10ST	340
57-SWA	205	CC-3	680	EG-2	130	LA-24	8,900	D-10S	340
17	190	CC-3C	800	PS-1	130	LA-31	900	D-20S	400
5B	195	CC-4	1,900	Dial Sheet Gauge		LA-7	800	D-50S	700
5B-HG	195	CC-5	2,500	K-1	3,120	LA-14	950	D-50SWA	720
5F	155	CC-6	5,000	K-2	4,750	LB-1	790	D-100S	900
5-SWF	210	CG-01	390	K-3	4,450	LB-2	650	D-100SWA	920
5-DX	220	CG-1	650	K-4	4,500	LB-3	800	DN-10S	340
5S	120	CG-2	660	K-7	7,800	LB-4	820	DN-20S	400
25	235	CG-3	700	Dial Upright Gauge		LB-5	1,030	D-10SS	350
25F-RE	255	CG-3C	750	R1-A	3,350	LB-6	810	D-10HS	280
55	225	CG-4	1,900	R1-B	3,250	LB-8	950	DL-2	260
55-DX	180	CG-5	2,500	R1-C	3,300	LB-9	1,050	DL-2S	260
25S	220	CG-6	4,600	Dial Depth Gauge		LH-2	500	Digital Counter	
56	180	CC-1S	470	T-1	700	LB-7	820	C-500	1,200
207	245	CC-2S	520	T-1W	395	LB-7S	770	C-700	1,200
207F-PL	300	CC-3S	580	T-2	300	LB-7V	1,300	Digital Gauge	
207S	195	CC-3CS	580	T-2W	325	LB-14	920	DG-205	240
207S-LL	200	CC-01R	380	T-2B	245	Tester		DG-127	230
207W	220	CC-1R	700	T-2C	290	NB	6,000	DG-257	240
207WF-T	195	CC-2R	700	T-3	300	Bench Center		PDN-21	380
307	320	CC-3R	750	T-4	280	OA	80,000	PDN-51	700
307S	310	CC-3CR	800	T-6A	270	Others		Digital Thickness Gauge	
507	440	CG-01R	380	T-6B	270	Dial Inside Gauge		YM-1	340
509	440	CG-1R	650	U-1	330			G2-205	400
809	1,150	CG-2R	660	U2HA	250	XY-1	150	G2-205M	400
36A	135	CG-3R	700	U2HB	250	XY-2	100	G2-257	400
36B	135	CG-3CR	750	U2FA	380	XZ-1	155	G2-127M	390
47	110	Dial Thickness Gauge		U2FB	380	XZ-2	155	G2-205A	400
47F	100	G	165	U3HA	250	GH-1	300	G2-257A	400
57S	140	G-1A	165	U3HB	250			G2-257M	400
57SF	125	G-1M	165	Stand				G2-127A	390
196A	115	G-2	370	SIS-4F		5,800	Signal Gauge		
196A-6	115	G-3	355	SIS-6C		3,650	S-5	260	
196B	110	G-4	320	SIS-7		2,600	S-7	260	
196B-T	110	G-6	280	PDS-2		7,150	S-9	260	
107Z	160	G-6C	300	PDS-2F		7,150	SC-2A	240	
107Z-XB	160	G-7C	280	Magnetic Stand				Signal Box	
17B	190	G-0.4N	165	YM-1	1,500			SB-3	1,500
17BF	150	G-2.4N	165	YM-2	2,000				
17Z	160	G-20	180	YM-3	1,500				
17Z-SWA	160	G-30	200						
117Z	160	H	280						

Quick Chart for "PEACOCK" Dial Gauge

We have named our dial gauge by model numbers, which indicate measurement range and graduation, instead of product code numbers.

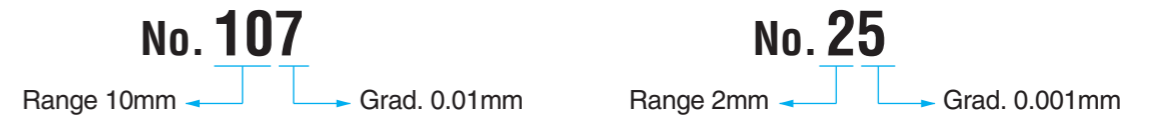

Our model numbers are:

The first and second digit numbers (1, 2, 4, 10, 20, 30, 50, 80) signify measurement ranges.

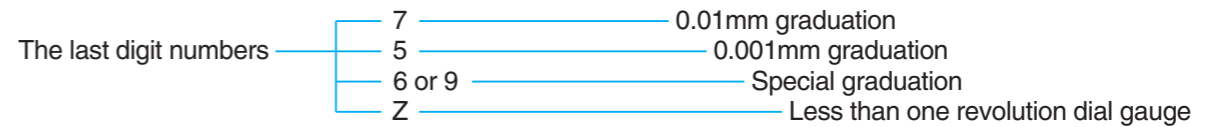

Exceptions: 1. Model No. 5 signifies 1mm measurement range with 0.001mm graduation.
2. Model No. 196A, 196B signify 5mm measurement range with 0.01mm graduation.

Grad.(mm)	Range(mm)	Model	Description
0.01	1	No. 17	(Small dial face)
	3	No. 36B	(Small dial face)
	4	No. 47	(Small dial face)
	5	No. 57	(B: balanced dial. S: small dial face)
	10	No. 107	(F-T: continuous CCW dial. SWA: oil-proof)
	20	No. 207	(S: small dial face. W: center pointer)
	30	No. 307	
	50	No. 507	
	5	No. 196A	(Back plunger, stem ϕ 6.35mm)
	5	No. 196A-6	(Back plunger, stem ϕ 6mm)
5	No. 196B	(Back plunger, stem ϕ 8mm)	
0.05	50	No. 509	
0.1	80	No. 809	
0.001	1	No. 5B	(5SWF: oil-proof. 5S: small dial face)
	2	No. 25	(S: small dial face)
	5	No. 55	
0.005	3	No. 36A	(Small dial face)
	5	No. 56	

Model	Description
17Z	(With carbide contact point)
17Z-SWA	(Oil-proof, carbide contact point)
17B	(White dial face)
47Z-XB	(Long stem, carbide contact point)
47Z	(Long stem, carbide contact point)
47SZ	(Short stem, carbide contact point)
107Z-XB	(Long stem, carbide contact point)
107Z	(Long stem, flat carbide contact point)
196Z	(Long stem, carbide contact point)
5Z-XB	(Long stem, carbide contact point)
5Z	(Long stem, flat carbide contact point)
15Z	(Short stem, carbide contact point)
15Z-SWF	(Oil-proof, carbide contact point)
18	(Long stem, white dial face, carbide contact point)

Name of Parts

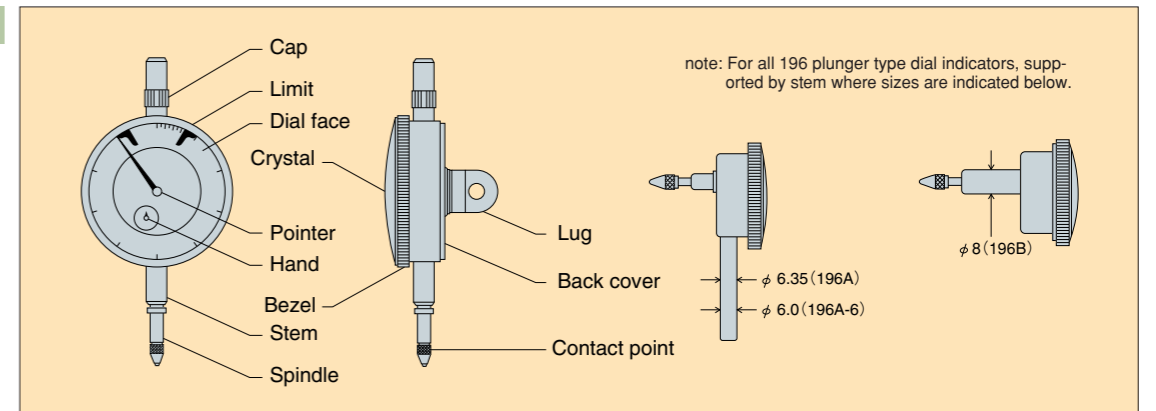

Quick Chart for "PEACOCK" Lever-Type Dial Indicators

Lever-type dial indicators are most suitable for alignment and TIR (Total Indicator Run-Out) testing. There are two types of lever-type dial indicators. Pivot bearings are used on all of Peacock's lever-type indicators, which assure exceptional precision over a long period of time.

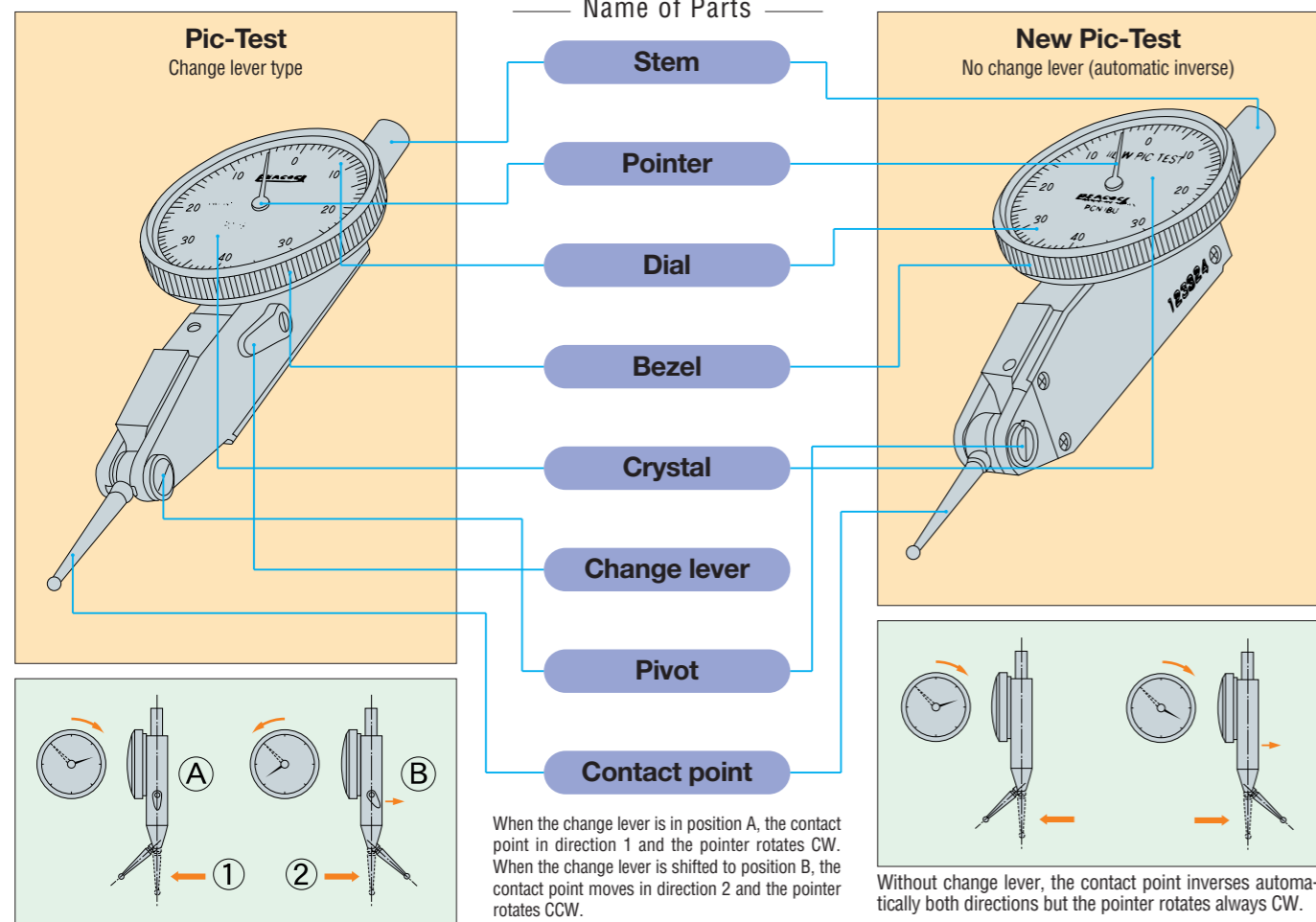

For particular requirements PC and PCN series are available. Model numbers ending with U, E, D or W signify particular applications.

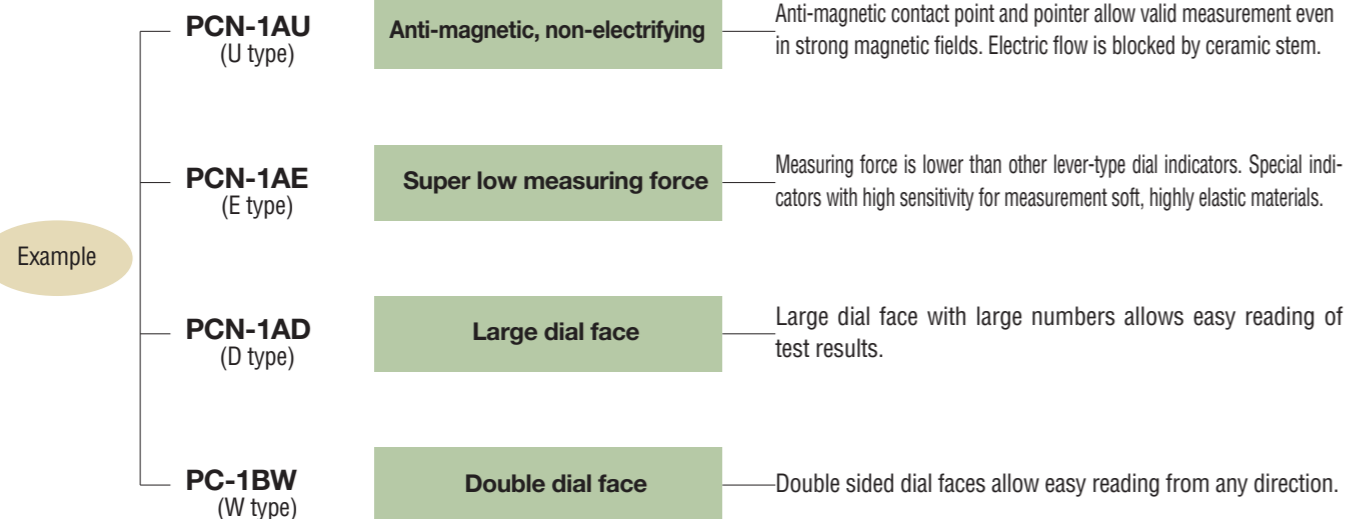

Table for Pic-Test and New Pic-Test

● items are made to order.

	Grad (mm)	Range (mm)	Model	Length of contact point (ℓ size)	Indicator types						
					U	E (measuring force)	D	W	Z		
PC with change lever	0.01	0.5	PC-1A	18.20mm	●	PC-1AE	Less than 0.1N	●	—	—	
			PC-3 (parallel)	18.20mm	●	—	—	—	—	—	
		0.8	PC-1B	19.24mm	●	PC-1BE	Less than 0.1N	—	PC-1BW	—	
	0.002	0.28	1.0	PC-1L	39.72mm	●	PC-1LE	Less than 0.1N	—	—	
			PC-2	8.80mm	●	●	—	—	—	—	
		PC-4 (parallel)	8.80mm	●	—	—	—	—	—		
PCN without change lever	0.01	0.5	PCN-0	17.74mm	—	—	—	—	—	—	
			PCN-1A	17.74mm	PCN-1AU	PCN-1AE	Less than 0.05N	PCN-1AD	—	—	
			PCN-5 (vertical)	17.74mm	PCN-5U	—	—	—	—	—	
		0.8	PCN-1B	18.63mm	PCN-1BU	PCN-1BE	Less than 0.05N	—	—	PCN-1BZ(A) PCN-1BZ(B)	
			1.0	PCN-1L	39.00mm	PCN-1LU	PCN-1LE	Less than 0.05N	PCN-1LD	—	PCN-1LZ(A) PCN-1LZ(B)
			1.5	PCN-7A	17.74mm	—	—	—	—	—	—
	0.002	0.2	PCN-2B	13.00mm	PCN-2BU	—	—	—	—	—	
			PCN-2	14.18mm	PCN-2U	PCN-2E	Less than 0.1N	PCN-2BD	—	PCN-2Z(A) PCN-2Z(B)	
		0.28	PCN-6 (vertical)	14.18mm	PCN-6U	—	—	—	—	—	
	0.001	0.14	0.6	PCN-7C	13.00mm	—	—	—	—	—	
			PCN-S	8.13mm	PCN-SU	—	—	—	—	—	
		0.2	—	13.00mm	—	—	—	PCN-SD	—	—	

We can customize Pic-Test and New Pic-Test indicators according to your special needs. Please contact Peacock for details.

Contact Points Ball Size

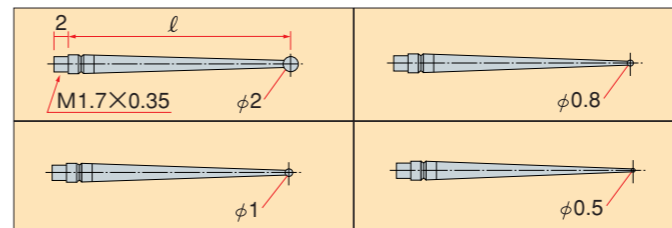

Warning!

Contact points are not interchangeable among different models. Each indicator is assigned a specific contact point length as shown in the table below. Not using proper contact point for assigned model will result in inaccuracy.

Contact points with φ 2mm carbide ball are attached to all Pic-Test indicators. φ 1.0mm, φ 0.8mm, and φ 0.5mm contact points are also available from our stock.

Lengths of contact points with φ 2mm carbide ball (actual size)

8.13mm	PCN-S PCN-SU	18.20mm	PC-1A PC-1AE PC-3
8.80mm	PC-2 PC-4	18.63mm	PCN-1B PCN-1BU PCN-1BE
13.00mm	PCN-2B PCN-SD PCN-2BU	19.24mm	PC-1B PC-1BE PC-1BW
14.18mm	PCN-2 PCN-2U PCN-2E	39.00mm	PCN-1L PCN-1LU PCN-1LE PCN-1LD
17.74mm	PCN-0 PCN-1A PCN-1AU PCN-1AE	39.72mm	PC-1L PC-1LE PC-1LW

※ φ2mm Ruby ball are available for PC-1A, PC-1B, PC-1L, PC-2, PCN-1A, PCN-1B, PCN-1L, PCN-2, PCN-2B and PCN-S

Quick Chart for "PEACOCK" Cylinder Gauges

For Both Blind Hole And Deep Bore Measuring

Select the best fitted probe length according to the measuring depth.

- CC Series (standard)
- CG Series (blind hole)

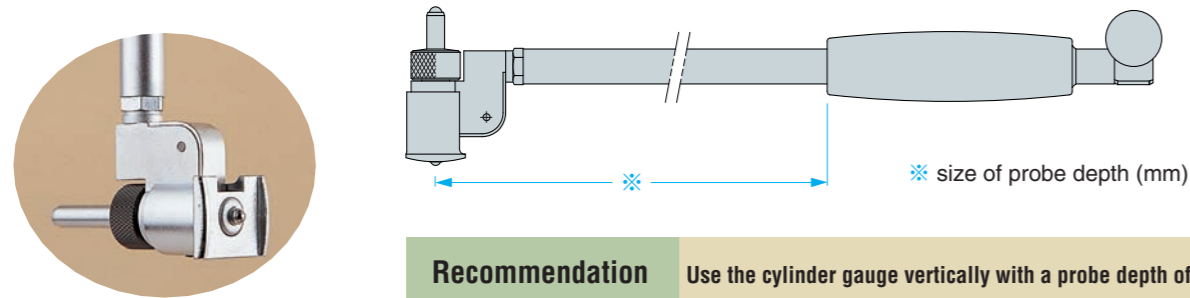

Recommendation Use the cylinder gauge vertically with a probe depth of 400mm or longer.

CC Series

Model	Measurement inner dia	Probe depth (mm)														
		50	100	150	200	250	300	400	500	600	700	800	900	1000	1500	2000
CC-02	φ 6~φ 10	●	—	—	—	—	—	—	—	—	—	—	—	—	—	—
CC-01	φ 10~φ 18	●	●	—	●	—	●	—	—	—	—	—	—	—	—	
CC-1	φ 18~φ 35	1. ●	●	●	—	●	●	—	—	—	—	—	—	—	—	
CC-2	φ 35~φ 60	2. ●	●	●	—	●	●	●	●	●	●	●	●	●	●	
CC-3	φ 50~φ 100	3. ●	●	●	—	●	●	●	●	●	●	●	●	●	●	
CC-3C	φ 50~φ 150	4. ●	●	●	—	●	●	●	●	●	●	●	●	●	●	
CC-4	φ 100~φ 160	●	●	—	●	●	●	●	●	●	●	●	●	●	●	
CC-5	φ 160~φ 250	●	●	—	●	●	●	●	●	●	●	●	●	●	●	
CC-6	φ 250~φ 400	●	●	—	●	—	●	●	●	●	●	●	●	●	●	

● More than L=600mm for CC-2 can not measure from 35 to 44mm and can measure from 45 to 60mm ID.

- are standard probe depth sizes
- are short type standard items. (Please order by model no.)
- 1. CC-1S (φ 18 ~ φ 35)
- 2. CC-2S (φ 35 ~ φ 60)
- 3. CC-3S (φ 50 ~ φ 100)
- 4. CC-3CS (φ 50 ~ φ 150)

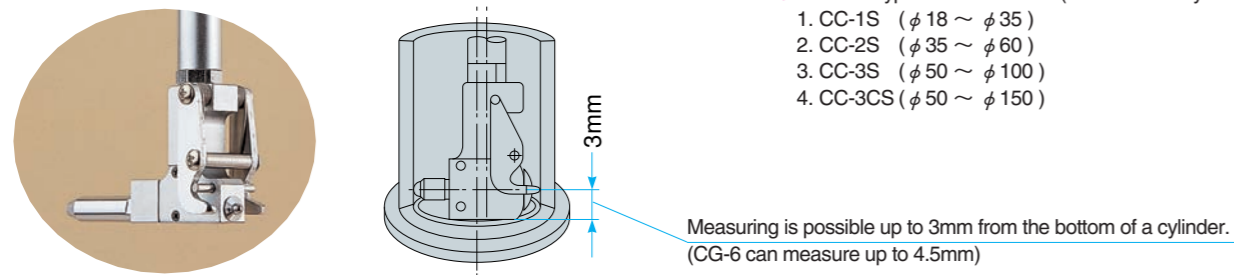

CG Series

Model	Measurement inner dia	Probe depth (mm)												
		50	100	150	200	250	300	400	500	600	700	800	900	1000
CG-01	φ 10~φ 18	●	●	●	●	●	—	—	—	—	—	—	—	—
CG-1	φ 18~φ 35	●	●	●	●	●	●	●	—	—	—	—	—	—
CG-2	φ 35~φ 60	●	●	●	●	●	●	●	●	●	●	●	●	●
CG-3	φ 50~φ 100	●	●	●	●	●	●	●	●	●	●	●	●	●
CG-3C	φ 50~φ 150	●	●	●	—	●	●	●	●	●	●	●	●	●
CG-4	φ 100~φ 160	●	●	●	●	●	●	●	●	●	●	●	●	●
CG-5	φ 160~φ 250	●	●	●	●	●	●	●	●	●	●	●	●	●
CG-6	φ 250~φ 400	●	●	●	●	●	●	●	●	●	●	●	●	●

● are standard probe depth sizes

Cylinder Gauges for Measuring Spline and Internal Gears

Easy and precise measurement of an **OVER PIN DIAMETER**, **LARGE** and **SMALL** diameter of **SPLINE** by our custom-manufactured **Cylinder Gauges**.

- Measuring OVER PIN diameter...Please specify diameters of over pin and balls.
- Measuring Large/Small diameter of the SPLINE...we will add a guide plate for accurate measurement by the shape of your work-piece.

Measuring OVER PIN Diameter

- Please specify diameters of Over pin and Balls.

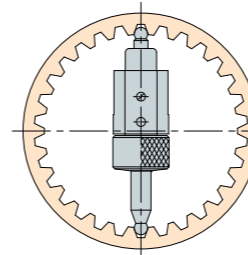

Even tooth

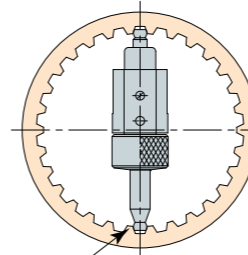

Even tooth

- We cut both tips of the balls when interference with Large diameter.

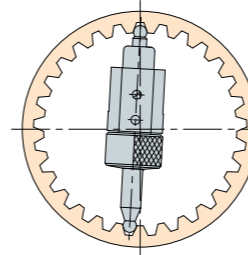

Odd tooth

Measuring Large Diameter

- Please specify large diameter (φ D), width and height of face. (We design contact points that do not touch either gear surface.)

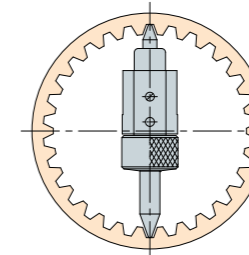

Even tooth

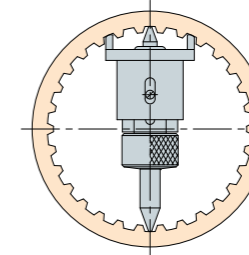

Even tooth

- In case the root diameter is wide, we will add guide plate.

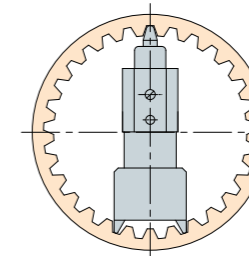

Odd tooth

- If the root of the face is not in the symmetry, the measurement points will across at any position. This is the reference of measurement by set a Master.

Measuring Small Diameter

- Please specify small diameter and height of face. (We design contact point guides on both sides of contact point.)

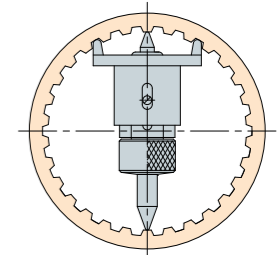

Even tooth

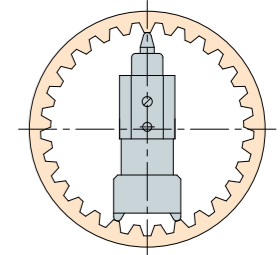

Odd tooth

- If the root of the face is not in the symmetry, the measurement points will across at any position. This is the reference of measurement by set a Master.

For Inquiries:

We provide quotes based on submitted workpiece drawings or actual workpiece examples. There is no minimum quantity required. Please specify what you want to measure, workpiece materials and tolerance. See page 20. (Please contact us directly or call a sales representative in your area.)

Request for Special Designed Cylinder Gauge

Measurement for Internal Gear Only
(Helical Gear is not acceptable as unstable.)

Date: _____

Name: _____

For your measurement, please check

Major Diameter

Minor Diameter

B.B.D=Between Ball Diameter or
O.P.D= Over Pin Diameter

Depth of measurement work-piece

_____ mm

Remark:

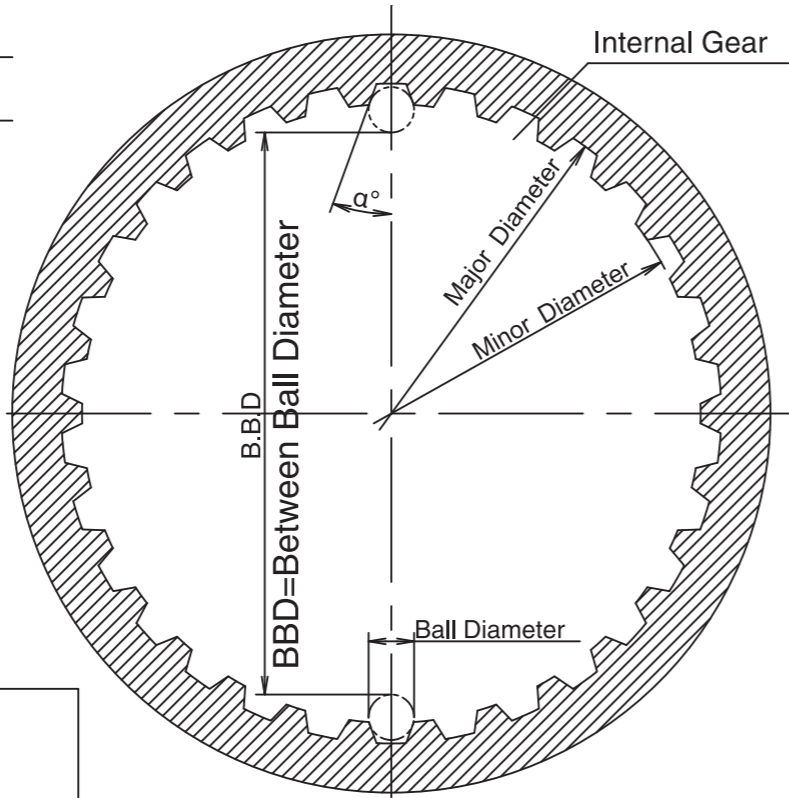

Specifications for BBD

B.B.D	Tolerance
Ball Diameter	$S\phi$ Ball Cut <input type="checkbox"/> Yes (cut) <input type="checkbox"/> No 
Major Diameter	Tolerance
Minor Diameter	Tolerance
Pressure Angle	$\alpha^\circ =$
No.of teeth	Z

Specifications for Major Diameter and Minor Diameter

B.B.D	Tolerance
Ball Diameter	$S\phi =$
Major Diameter	Tolerance
Minor Diameter	Tolerance
Pressure Angle	$\alpha^\circ =$
No.of Teeth	Z

※ Conversion Table for Odd tooth is unready.

In case ball cut is necessary, we can provide the Master.

Master Production Yes No

Please enclose the Specification table with clear Tolerance for your measurement work-piece at the time of request.

OZAKI MFG. CO., LTD. TOKYO, JAPAN

URL: <http://www.peacockozaki.jp/eng.htm>

Tel: +81 3 3966 1109

Fax: +81 3 3558 1868





Dial Gauges

- One Revolution Dial Gauges
- Standard Dial Gauges
(0.01mm, 0.005mm, 0.001mm)
- Long Travel Dial Gauges
(0.01mm, 0.05mm, 0.1mm)
- Miniature Dial Gauges
(0.001mm, 0.005mm, 0.01mm)
- Back Plunger Type Dial Gauges
- Accessories
- Technical Data
- Marking Service

One Revolution Dial Gauges

0.001mm and 0.01mm Z series

- These are high-accuracy dial gauges with the pointer giving less than a full turn that can resist rigorous continuous measurement. The long stem is made of stainless steel, is high in strength and is malfunction-free due to fastening. The dial faces except No. 18 and 17B are easy to read with green and orange (dead zone)

0.001mm Type



15Z
Graduation: 0.001mm
Range: 0.16mm

- Contact point (XB-1)
- Flat back



15Z-SWF
Graduation: 0.001mm
Range: 0.16mm

- Contact point (XB-2A)
- Oil-proof type
- Flat back



5Z-XB
Graduation: 0.001mm
Range: 0.14mm

- Contact point (XB-1)
- Flat back

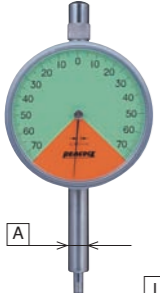

5Z
Graduation: 0.001mm
Range: 0.14mm

- Long stem
- Flat back



18
Graduation: 0.001mm
Range: 0.16mm

- Long stem
- Contact point (XB-1)
- Oil-proof type
- Flat crystal
- Flat back



15DZ
Graduation: 0.001mm
Range: 0.16mm

- Large dial face (φ 66.5)
- Contact point (XB-1)
- Flat back

φ 4.0 Flat carbide contact point (XB-406)

0.01mm Type



17Z
Graduation: 0.01mm
Range: 0.8mm

- Contact point (XB-1)
- Flat back



17Z-SWA
Graduation: 0.01mm
Range: 0.8mm

- Oil-proof type
- Contact point (XB-2)
- Flat back



107Z-XB
Graduation: 0.01mm
Range: 0.8mm

- Long stem
- Contact point (XB-1)
- Flat back

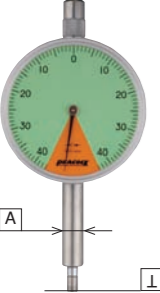

107Z
Graduation: 0.01mm
Range: 0.8mm

- Long stem
- Flat back



17B
Graduation: 0.01mm
Range: 0.8mm

- Contact point (X-1)
- Lug back



117Z
Graduation: 0.01mm
Range: 1.0mm

- Contact point (XB-1)
- Flat back

φ 4.0 Flat carbide contact point (XB-406)

Miniature Type

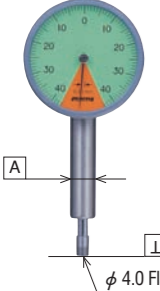

47Z
Graduation: 0.01mm
Range: 0.8mm

- Long stem
- Flat back



47Z-XB
Graduation: 0.01mm
Range: 0.8mm

- Contact point (XB-1)
- Flat back



47SZ
Graduation: 0.01mm
Range: 0.8mm

- Contact point (XB-1)
- Flat back

φ 4.0 Flat carbide contact point (XB-406)



- 147Z**
Graduation: 0.01mm
Range: 1.0mm
- Small dial face (φ 36)
 - Contact point (XB-1)
 - Flat back



- 36Z**
Graduation: 0.005mm
Range: 0.4mm
- Contact point (XB-1)
 - Flat back



- 196Z**
Graduation: 0.01mm
Range: 0.8mm
- Stem φ 8mm
 - Pointer giving less than one revolution
 - Contact point (X-112)

Specifications

Model	Graduation (mm)	Range (mm) (Free stroke)	Reading	Indication error (unit: μm)					Retrace error	Repeatability	Measuring force less than (N)
				1/10 revolution	1/2 revolution	One revolution	Two revolutions	Whole measuring range			
15Z	0.001	0.16 (3.0)	80 - 0 - 80	2.5	±3	±4	—	—	3	0.5	1.5
15Z-SWF	0.001	0.16 (3.0)	80 - 0 - 80	2.5	±3	±4	—	—	3	0.5	1.5
5Z-XB	0.001	0.14 (3.0)	70 - 0 - 70	2.5	±3	±4	—	—	3	0.5	1.5
5Z	0.001	0.14 (3.0)	70 - 0 - 70	2.5	±3	±4	—	—	3	0.5	1.5
18	0.001	0.16 (3.0)	80 - 0 - 80	2.5	±3	±4	—	—	3	0.5	1.5
17Z	0.01	0.8 (7.0)	40 - 0 - 40	8	±9	±10	—	—	5	5	1.4
17Z-SWA	0.01	0.8 (7.0)	40 - 0 - 40	8	±9	±10	—	—	5	5	1.4
107Z-XB	0.01	0.8 (7.0)	40 - 0 - 40	8	±9	±10	—	—	5	5	1.4
107Z	0.01	0.8 (7.0)	40 - 0 - 40	8	±9	±10	—	—	5	5	1.4
17B	0.01	0.8 (10.0)	40 - 0 - 40	8	±9	±10	—	—	5	5	1.4
15DZ	0.001	0.16 (3.0)	80 - 0 - 80	2.5	±3	±4	—	—	3	0.7	1.5
117Z	0.01	1.0 (7.0)	50 - 0 - 50	8	±9	±10	—	—	5	5	1.4
47Z	0.01	0.8 (4.0)	40 - 0 - 40	9	—	±13	—	—	6	5	1.4
47Z-XB	0.01	0.8 (4.0)	40 - 0 - 40	9	—	±13	—	—	6	5	1.4
47SZ	0.01	0.8 (4.0)	40 - 0 - 40	9	—	±13	—	—	6	5	1.4
196Z	0.01	0.8 (4.0)	40 - 0 - 40	10	±12	±15	—	—	6	5	1.4
147Z	0.01	1.0 (4.0)	50 - 0 - 50	9	—	±13	—	—	6	5	1.4
36Z	0.005	0.4 (3.0)	20 - 0 - 20	—	—	±10	—	—	5	5	1.4

Note- All Dial Indicators (except for 196Z) listed above have flat back as standard.

Note- Lug back Model No. : 47ZL, 47Z-XBL, 47SZL, 147ZL, 36ZL.

Dimensions

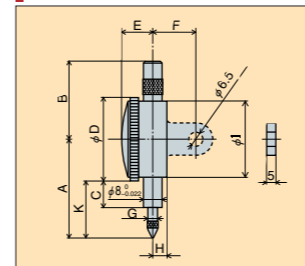

Dimensions 196Z

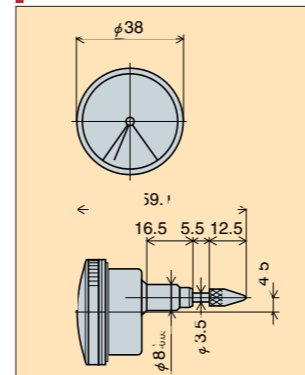

Sizes

Model		A	B	C	D	E	F	G	H	I	K
Flat back type	Lug back type										
15Z	15ZL	60	41.5	18.5	53	14.5	(20)	4	6.5	49	33.5
15Z-SWF	15Z-SWFL	62.5									36
5Z-XB	5Z-XBL	69.4		30	42.9						
5Z	5ZL	66.4	29	55	16.8	(20)	4	6.5	49	39.9	
18	18L	69.4								41.9	
17Z	17ZL	65	18.5	30	53	14.5	(20)	4	5.8	32	38.5
17Z-SWA	17Z-SWAL	65									38.5
107Z-XB	107Z-XBL	69.4	30	53	14.5	(20)	4	6.5	49	42.9	
107Z	107ZL	66.4								39.9	
17BF	17B	65	40.5	18.5			20(-)				38.5
117Z	117ZL	65	41.5	18.5			(20)				38.5
15DZ	15DZL	69.4	41.5	23.7	66.5	15.5			7.6		36
47Z	47ZL	58.9	20	30	36	13	(15)	3.5	6.5	49	40.9
47Z-XB	47Z-XBL	61.9									43.9
47SZ	47SZL	41.1	9.7	36	13	(15)	3.5	6.5	49	23.1	
147Z	147ZL	41.1								23.1	
36Z	36ZL	60	41.5	18.5	53	14.5	(20)	4			33.5

Note- () indicates the model number of lug back and its size. Both lug back and flat back share the same size except for the items listed under column F.

Standard Dial Gauges

JIS B 7503

0.001mm and 0.005mm

Dial Gauges are widely used manufacturing plants.

- The stem, made of SK quench hardened with strength, is malfunction-free due to fastening.
- The shock-proof mechanism prevents gears from damage due to shocks arisen by abruptly pushing up the spindle.
- The turning section of the outer frame sealed by the O-ring and the back inside sealed by the packing are water-proof and dust-proof in construction.
- The back is increased in strength by four screws, and the lug can be turned 90 degrees in the installation way.

<HG>

High Precision Type



5B-HG
Graduation: 0.001mm
Range: 1mm
● Indication error $\pm 3\mu\text{m}$
● Retrace error 2 μm
● Includes accuracy certification
● Lug back



5-DX
Graduation: 0.001mm
Range: 1mm
● Durable type (Spindle $\phi 5\text{mm}$)
● Lug back



5B
Graduation: 0.001mm
Range: 1mm
● Lug back



5F
Graduation: 0.001mm
Range: 1mm
● Flat back



5-SWF
Graduation: 0.001mm
Range: 1mm
● Oil-proof type
● Contact point (X-2A)
● Lug back

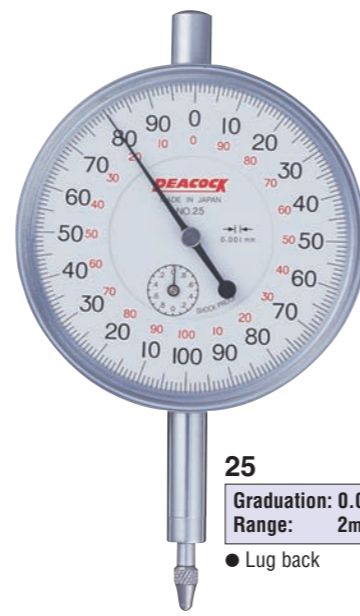

25
Graduation: 0.001mm
Range: 2mm
● Lug back

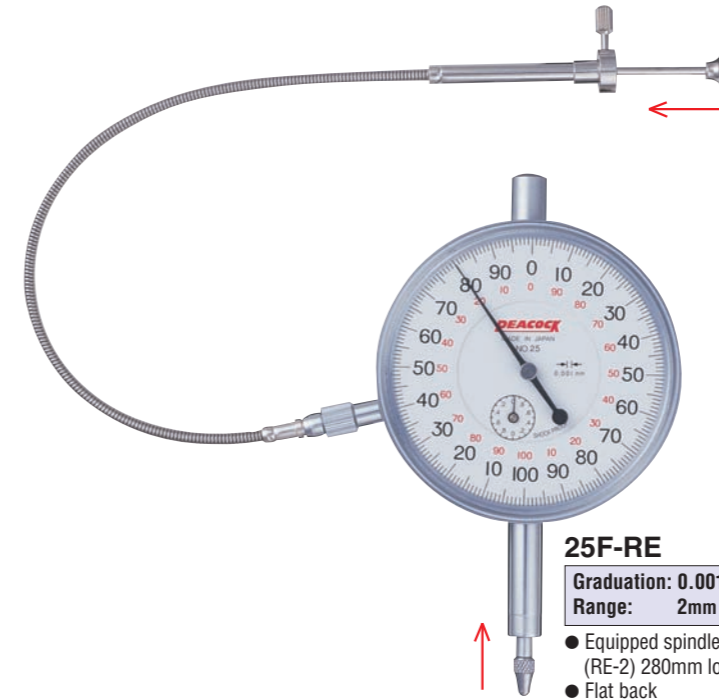

25F-RE
Graduation: 0.001mm
Range: 2mm
● Equipped spindle pull-up release (RE-2) 280mm long
● Flat back



25S
Graduation: 0.001mm
Range: 2mm
● Small dial face type ($\phi 55.7\text{mm}$)
● Lug back



55
Graduation: 0.001mm
Range: 5mm
● Lug back



55-DX
Graduation: 0.001mm
Range: 5mm
● Small dial face type ($\phi 57\text{mm}$)
● Lug back



56
Graduation: 0.005mm
Range: 5mm
● Lug back

Specifications

Model	Graduation (mm)	Range (mm)	Reading	Indication error					Retrace error	Repeatability	Measuring force less than (N)
				1/10 revolution	1/2 revolution	One revolution	Two revolutions	Whole measuring range			
5B-HG	0.001	1	0 - 100 - 0	2	± 2	± 3	± 3	± 3	2	0.5	1.5
5-DX	0.001	1	0 - 100 - 0	2.5	± 3	± 4	± 4	± 5	3	0.5	1.5
5B	0.001	1	0 - 100 - 0	2.5	± 3	± 4	± 4	± 5	3	0.5	1.5
5F	0.001	1	0 - 100 - 0	2.5	± 3	± 4	± 4	± 5	3	0.5	1.5
5-SWF	0.001	1	0 - 100 - 0	2.5	± 3	± 4	± 4	± 5	3	0.5	1.5
25	0.001	2	$\pm 0 - 100 - 100$	4	± 5	± 6	± 6	± 7	3	0.5	1.5
25F-RE	0.001	2	$\pm 0 - 100 - 100$	4	± 5	± 6	± 6	± 7	3	0.5	1.5
25S	0.001	2	0 - 100 - 0	4	± 5	± 6	± 6	± 7	3	0.5	1.5
55	0.001	5	0 - 100 - 0	5	± 6	± 7	± 8	± 10	4	1	1.5
55-DX	0.001	5	0 - 100 - 0	5	± 6	± 7	± 8	± 10	4	1	1.5
56	0.005	5	0 - 25 - 50	6	± 10	± 10	± 12	± 12	5	5	1.5

(unit: μm)

Standard Dial Gauges

JIS B 7503

0.01mm

Dial Gauges are widely used manufacturing plants.

- The stem, made of SK quench hardened with strength, is malfunction-free due to fastening.
- The shock-proof mechanism prevents gears from damage due to shocks arisen by abruptly pushing up the spindle.
- The turning section of the outer frame sealed by the O-ring and the back inside sealed by the packing are waterproof and dust-proof in construction.
- The back is increased in strength by four screws, and the lug can be turned 90 degrees in the installation way.

<HG>

High Precision Type



107-HG
Graduation: 0.01mm
Range: 10mm
● Indication error $\pm 10\mu\text{m}$
● Retrace error $4\mu\text{m}$
● Includes accuracy certification
● Lug back



107-DX
Graduation: 0.01mm
Range: 10mm
● Durable type (Spindle $\phi 5\text{mm}$)
● Lug back



107
Graduation: 0.01mm
Range: 10mm
● Lug back



107F
Graduation: 0.01mm
Range: 10mm
● Flat back



107-SWA
Graduation: 0.01mm
Range: 10mm
● Oil-proof type
● Flat crystal
● Contact point (X-2A)
● Lug back



107-BL
Graduation: 0.01mm
Range: 10mm
● Spindle pull-up back lever
● Lug back



107F-RE
Graduation: 0.01mm
Range: 10mm
● Spindle pull-up release (RE-1) 280 mm long
● Flat back



107-LL
Graduation: 0.01mm
Range: 10mm
● Spindle lifting lever (LL-1)
● Lug back

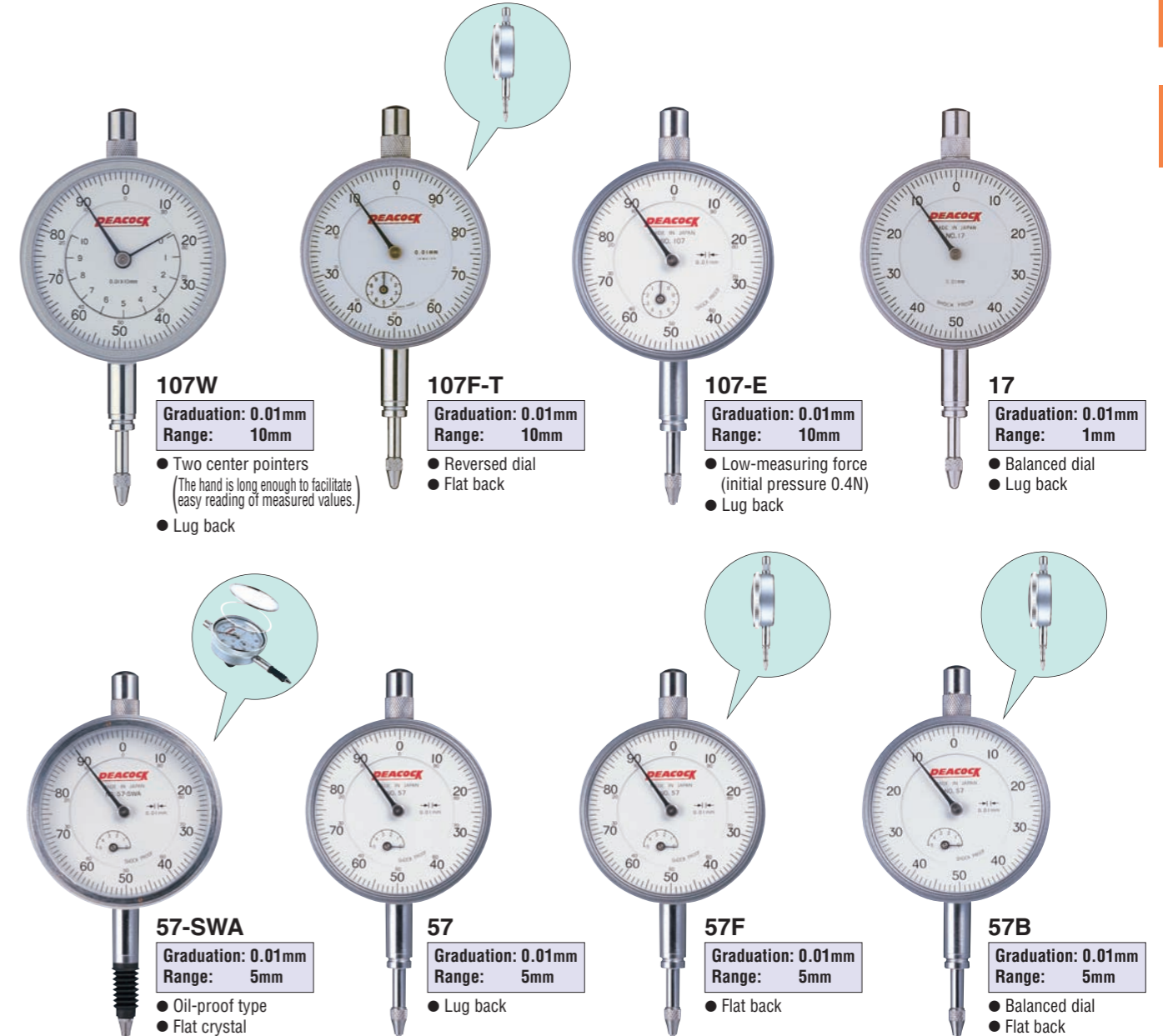

Specifications

Model	Graduation (mm)	Range (mm)	Reading	Indication error (unit: μm)					Retrace error	Repeatability	Measuring force less than (N)
				1/10 revolution	1/2 revolution	One revolution	Two revolutions	Whole measuring range			
107-HG	0.01	10	$\pm 0 - 50 - 100$	6	± 7	± 8	± 10	± 10	4	5	1.4
107-DX	0.01	10	$\pm 0 - 50 - 100$	8	± 9	± 10	± 15	± 15	5	5	1.4
107	0.01	10	$\pm 0 - 50 - 100$	8	± 9	± 10	± 15	± 15	5	5	1.4
107F	0.01	10	$\pm 0 - 50 - 100$	8	± 9	± 10	± 15	± 15	5	5	1.4
107-SWA	0.01	10	$\pm 0 - 50 - 100$	8	± 9	± 10	± 15	± 15	5	5	1.4
107-BL	0.01	10	$\pm 0 - 50 - 100$	8	± 9	± 10	± 15	± 15	5	5	1.4
107F-RE	0.01	10	$\pm 0 - 50 - 100$	8	± 9	± 10	± 15	± 15	5	5	1.4
107-LL	0.01	10	$\pm 0 - 50 - 100$	8	± 9	± 10	± 15	± 15	5	5	1.4
107W	0.01	10	$\pm 0 - 50 - 100$	8	± 9	± 10	± 15	± 15	5	5	1.4
107F-T	0.01	10	$\pm 100 - 50 - 0$	8	± 9	± 10	± 15	± 15	5	5	1.4
107-E	0.01	10	$\pm 0 - 50 - 100$	8	± 9	± 10	± 15	± 15	5	5	initial pressure 0.4
17	0.01	1	0 - 50 - 0	8	± 9	± 10	—	—	5	5	1.4
57-SWA	0.01	5	$\pm 0 - 50 - 100$	8	± 9	± 10	± 15	± 15	5	5	1.4
57	0.01	5	$\pm 0 - 50 - 100$	8	± 9	± 10	± 15	± 15	5	5	1.4
57F	0.01	5	$\pm 0 - 50 - 100$	8	± 9	± 10	± 15	± 15	5	5	1.4
57B	0.01	5	0 - 50 - 0	8	± 9	± 10	± 15	± 15	5	5	1.4

Standard Dial Gauges

Standard Dial Gauges

Long Travel Dial Gauges

JMAS 2001

0.01mm, 0.05mm and 0.1mm

Dial Gauges are widely used manufacturing plants.

- The stem, made of SK quench hardened with strength, is malfunction-free due to fastening.
- The shock-proof mechanism prevents gears from damage due to shocks arisen by abruptly pushing up the spindle.
- The turning section of the outer frame sealed by the O-ring and the back inside sealed by the packing are water-proof and dust-proof in construction.
- The back is increased in strength by four screws, and the lug can be turned 90 degrees in the installation way.

The position of the lever can be installed either right or left.

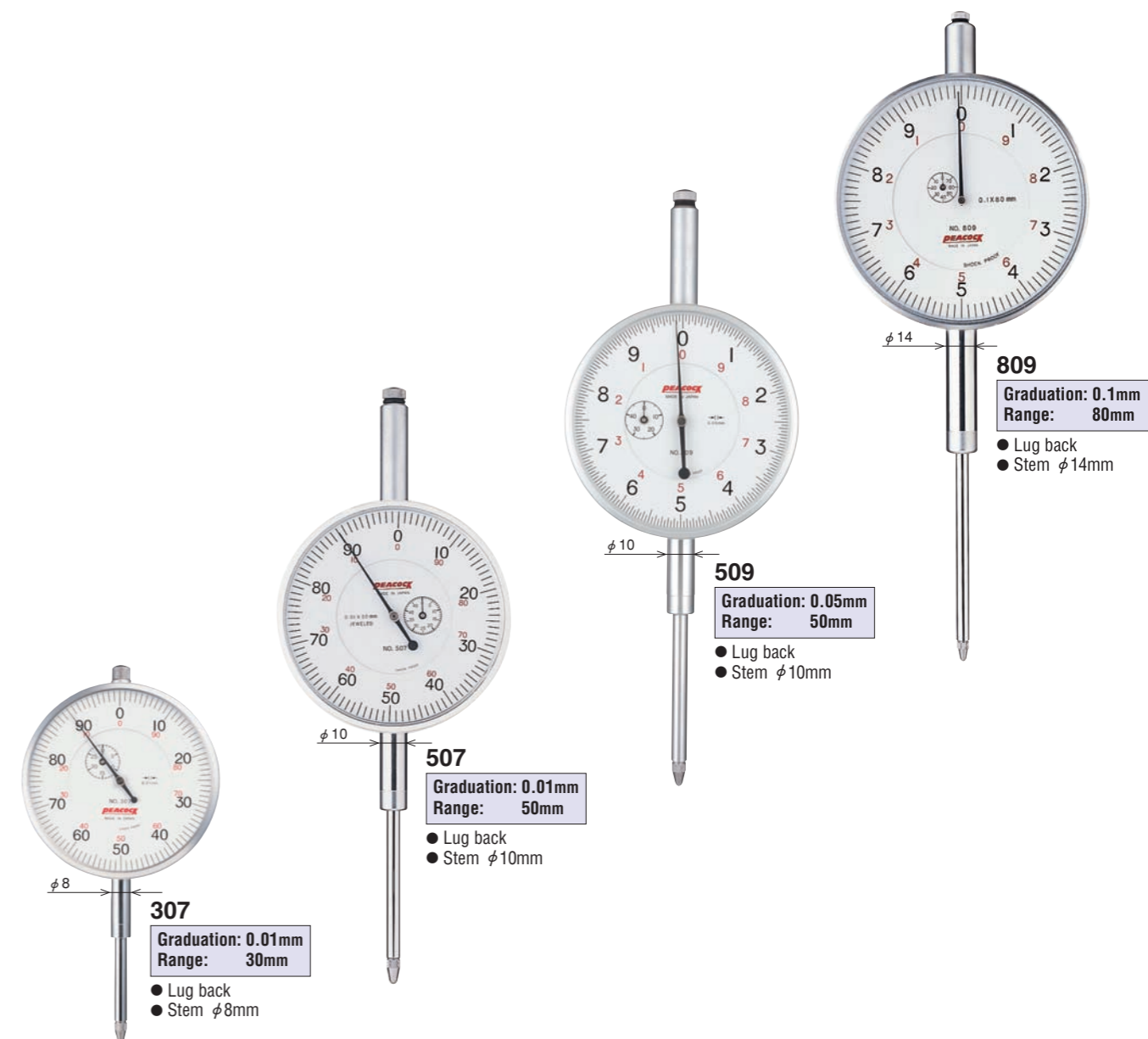
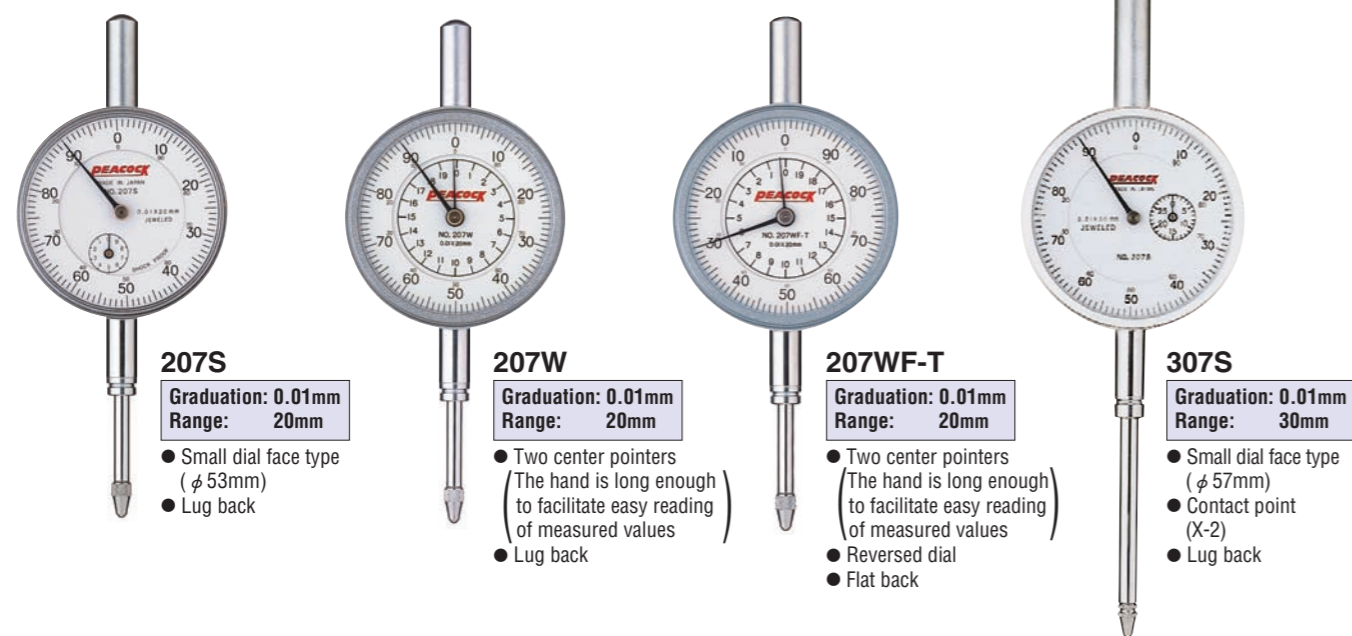
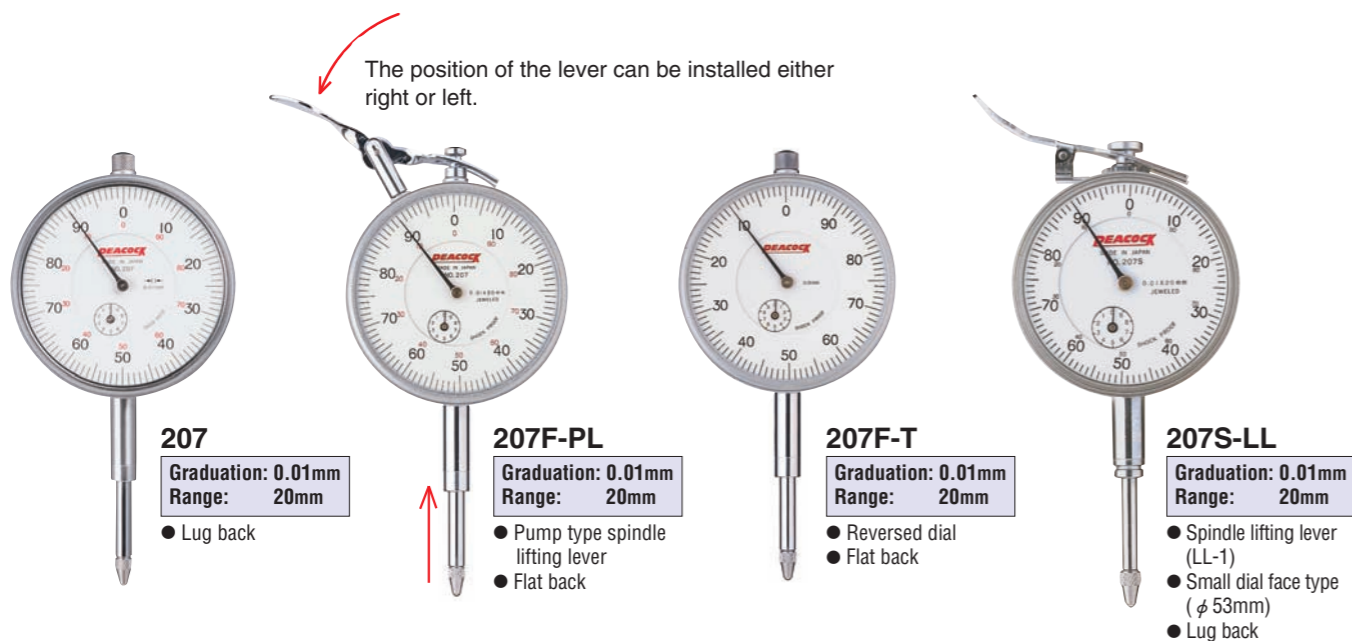

Specifications

Model	Graduation (mm)	Range (mm)	Reading	Indication error					Retrace error	Repeatability	Measuring force less than (N)
				1/10 revolution	1/2 revolution	One revolution	Two revolutions	Whole measuring range			
207	0.01	20	±0 - 50 - 100	10	—	±15	—	±20	7	5	2.0
207F-PL	0.01	20	±0 - 50 - 100	10	—	±15	—	±20	7	5	2.0
207F-T	0.01	20	±100 - 50 - 0	10	—	±15	—	±20	7	5	2.0
207S-LL	0.01	20	±0 - 50 - 100	10	—	±15	—	±20	7	5	2.0
207S	0.01	20	±0 - 50 - 100	10	—	±15	—	±20	7	5	2.0
207W	0.01	20	±0 - 50 - 100	10	—	±15	—	±20	7	5	2.0
207WF-T	0.01	20	±100 - 50 - 0	10	—	±15	—	±20	7	5	2.0
307S	0.01	30	±0 - 50 - 100	14	—	±18	—	±25	7	5	2.2
307	0.01	30	±0 - 50 - 100	14	—	±18	—	±25	7	5	2.2
507	0.01	50	±0 - 50 - 100	15	—	±20	—	±35	9	5	2.5
509	0.05	50	±0 - 5 - 10	30	—	±100	—	±100	10	20	2.5
809	0.1	80	±0 - 5 - 10	50	—	±100	—	±100	—	35	2.5

(unit: μm)

Long Travel Dial Gauges

Long Travel Dial Gauges

Miniature Dial Gauges

JMAS 2003

0.001mm, 0.005mm and 0.01mm

- These compact size dial gauges are equipped with small dial faces. They are especially useful for measuring jigs, in restricted areas.



5S
Graduation: 0.001mm
Range: 1mm
● Contact point (X-107)
● Flat back
● Dial dia. ϕ 40.8mm

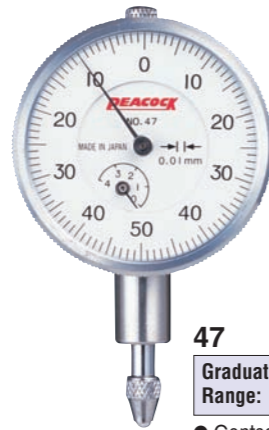

47
Graduation: 0.01mm
Range: 4mm
● Contact point (X-107)
● Lug back
● Dial dia. ϕ 36mm



47F
Graduation: 0.01mm
Range: 4mm
● Contact point (X-107)
● Flat back
● Dial dia. ϕ 36mm



57S
Graduation: 0.01mm
Range: 5mm
● Contact point (X-105)
● Lug back
● Dial dia. ϕ 39mm



36A
Graduation: 0.005mm
Range: 3mm
● Contact point (X-107)
● Lug back
● Dial dia. ϕ 40.8mm



36B
Graduation: 0.01mm
Range: 3mm
● Contact point (X-107)
● Lug back
● Dial dia. ϕ 40.8mm



Specifications

Model	Graduation (mm)	Range (mm)	Reading	Indication error					Retrace error	Repeatability	Measuring force less than (N)
				1/10 revolution	1/2 revolution	One revolution	Two revolutions	Whole measuring range			
5S	0.001	1	$\pm 0 - 100 - 100$	5	± 6	± 7	± 8	± 10	4	5	1.5
47	0.01	4	0 - 50 - 0	9	—	± 13	—	± 15	6	5	1.4
47F	0.01	4	0 - 50 - 0	9	—	± 13	—	± 15	6	5	1.4
57S	0.01	5	$\pm 0 - 50 - 100$	9	—	± 13	—	± 15	6	5	1.4
36A	0.005	3	$\pm 0 - 25 - 50$	9	—	± 13	—	± 15	6	5	1.4
36B	0.01	3	0 - 25 - 50	9	—	± 13	—	± 15	6	5	1.4

(unit: μ m)

Back Plunger Type Dial Gauges

0.01mm

- The back plunger dial gauge is characterized with easy handling since the spindle having the contact point moves in the direction perpendicular to the dial face and the gauge is more compact.
- The dial gauge of this type is convenient for use in achieving a parallelism of the table of the machine tool, with measuring jigs, in restricted areas and on locations where scale reading is difficult.



196A
Graduation: 0.01mm
Range: 5mm
● Stem ϕ 6.35mm
● Contact point (X-1)



196A-6
Graduation: 0.01mm
Range: 5mm
● Stem ϕ 6mm
● Contact point (X-1)



196Z
Graduation: 0.01mm
Range: 0.8mm
● Stem ϕ 8mm
● Pointer giving less than one revolution
● Contact point (X-112)



196B
Graduation: 0.01mm
Range: 5mm
● Stem ϕ 8mm
● Contact point (X-112)



196B-T
Graduation: 0.01mm
Range: 5mm
● Stem ϕ 8mm
● Reversed dial
● Contact point (X-112)

Dimensions (Holder for 196B)

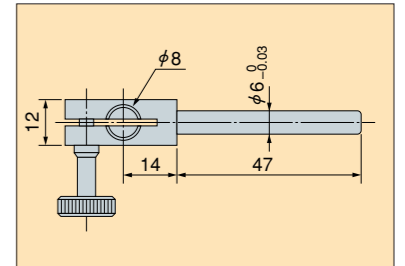

Specifications

Model	Graduation (mm)	Range (mm)	Reading	Indication error					Retrace error	Repeatability	Measuring force less than (N)
				1/10 revolution	1/2 revolution	One revolution	Two revolutions	Whole measuring range			
196A	0.01	5	0 - 50 - 100	10	± 12	± 15	± 20	± 20	6	5	1.4
196A-6	0.01	5	0 - 50 - 100	10	± 12	± 15	± 20	± 20	6	5	1.4
196Z	0.01	0.8	40 - 0 - 40	10	± 12	± 15	—	—	6	5	1.4
196B	0.01	5	0 - 50 - 100	10	± 12	± 15	± 20	± 20	6	5	1.4
196B-T	0.01	5	100 - 50 - 0	10	± 12	± 15	± 20	± 20	6	5	1.4

※ Dial dia. ϕ 38mm (All Back Plunger type Dial Gauges)

Replaceable Contact Point (Screw pitch M2.5 × 0.45mm)

for Dial Indicators and Linear Gauges

● Ball Contact Point

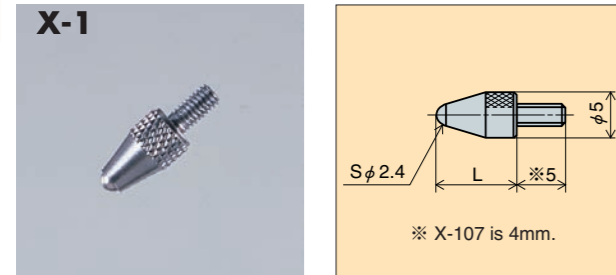

Part No.	L (mm)	Material
X-1	9	Steel
X-103	3.5	Steel
X-105	5	Steel
X-107	7.5	Steel
X-112	12.5	Steel
X-125	25	Steel
XB-1	9	Carbide
XB-115	15	Carbide
XB-125	25	Carbide
XB-130	30	Carbide
XC-1	9	Ruby
XC-125	25	Ruby

● Ball Contact Point for Oil Proof type

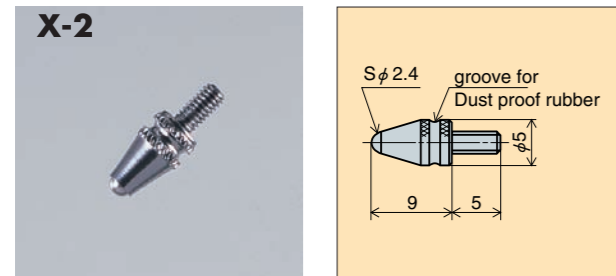

Part No.	L (mm)	Material
X-2	9	Steel
XB-2	9	Carbide
XC-2	9	Ruby
X-2A	12	Steel
XB-2A	12	Carbide

● Special Contact Point

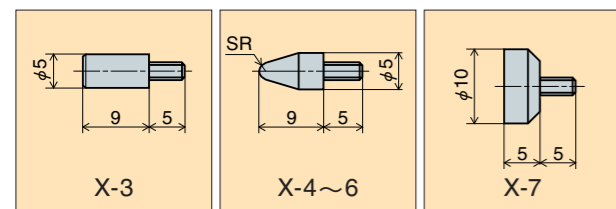

Part No.	Material
X-3	NSB
X-4	Copper
X-5	Bakelite
X-6	Teflon
X-7	Teflon

● Offset Contact Point

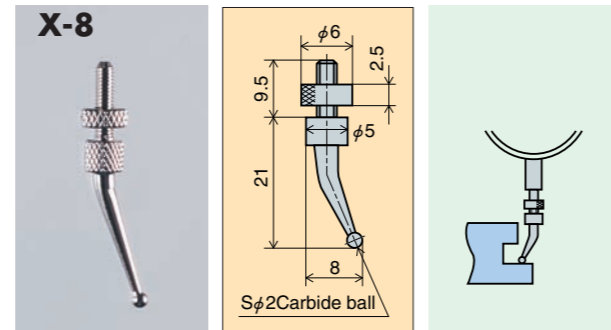

Part No.	Material
X-8	Carbide

● Special Contact Point

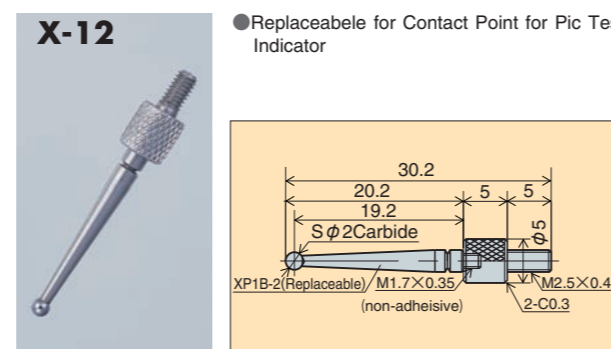

Part No.	Material
X-12	Carbide

● Spherical Contact Point

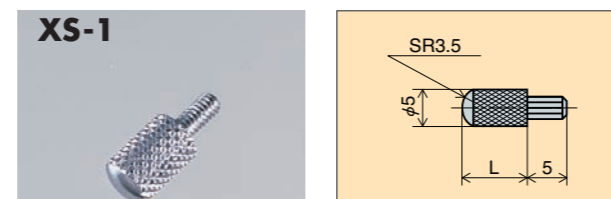

XS-1 series

Part No.	L (mm)	Material
XS-1	8	SKS3
XS-105	5	SKS3
XS-110	10	SKS3
XS-115	15	SKS3
XS-120	20	SKS3
XS-125	25	SKS3
XS-130	30	SKS3

Replaceable Contact Point (Screw pitch M2.5 × 0.45mm)

for Dial Indicators and Linear Gauges

● Flat Contact Point

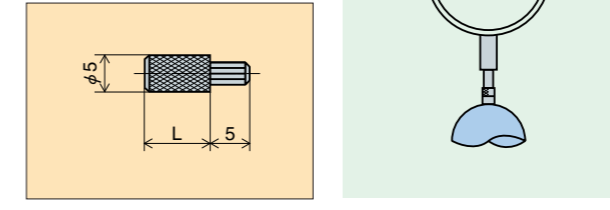
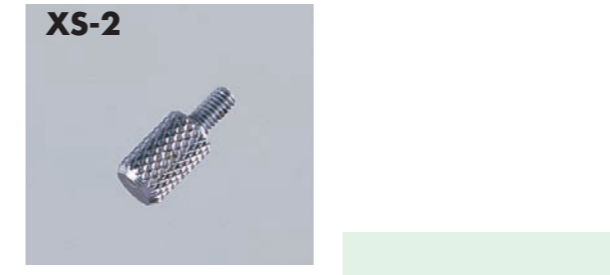

XS-2 series

Part No.	L (mm)	Material
XS-2	8	SKS3
XS-205	5	SKS3
XS-210	10	SKS3
XS-215	15	SKS3
XS-220	20	SKS3
XS-225	25	SKS3
XS-230	30	SKS3

● Taper Contact Point

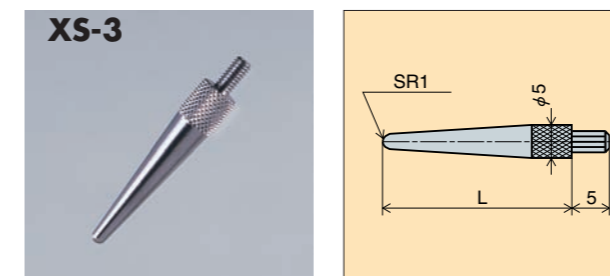

XS-3 series

Part No.	L (mm)	Material
XS-3	25	SKS3
XS-310	10	SKS3
XS-315	15	SKS3
XS-320	20	SKS3
XS-330	30	SKS3

● Plain Contact Point

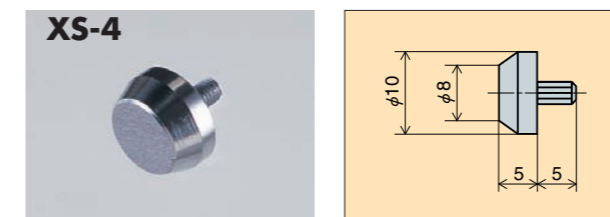

XS-4 series

Part No.	Material
XS-4	SKS3

● Flat Contact Point

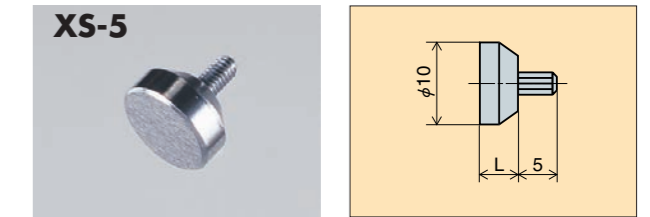

XS-5 series

Part No.	L (mm)	Material
XS-5	5	SKS3
XS-510	10	SKS3

● Button type Contact Point

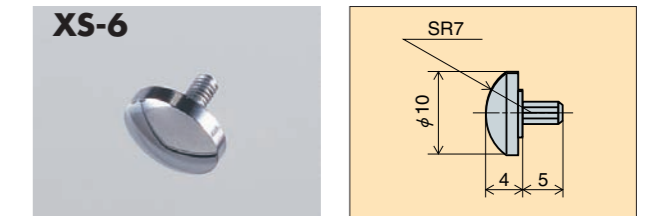

XS-6 series

Part No.	Material
XS-6	SKS3

● Contact Point set XS



※XS is provided with setting table for XS-1 to XS-6 contact points, and a case. Each type sold separately.

Part No.	Material
XS	SKS3

● Knife-edge Contact Point

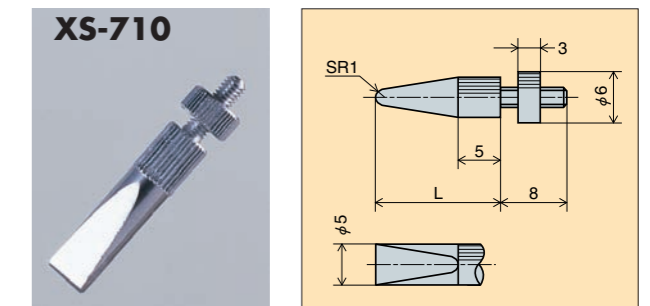

Part No.	L (mm)	Material
XS-710	10	SKS3
XS-715	15	SKS3
XS-720	20	SKS3
XS-725	25	SKS3
XS-730	30	SKS3

Replaceable Contact Point (Screw pitch M2.5 × 0.45mm)

for Dial Indicators and Linear Gauges

● Carbide Spherical Contact Point

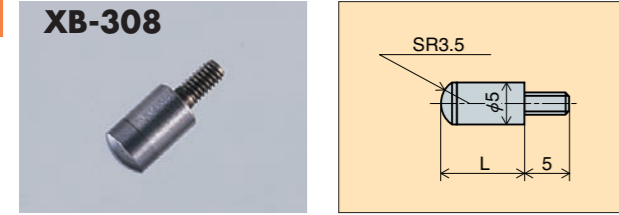

Part No.	L (mm)	Material
XB-305	5	Carbide
XB-308	8	Carbide

● Carbide Flat Contact Point

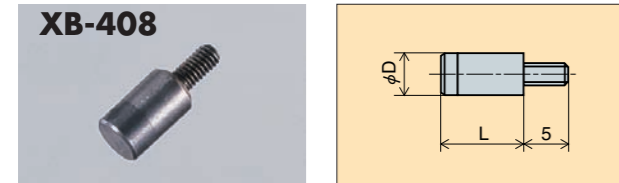

Part No.	φ D (mm)	L (mm)	Material
XB-405	5	5	Carbide
XB-406	4	6	Carbide
XB-408	5	8	Carbide

● Carbide Plain Contact Point

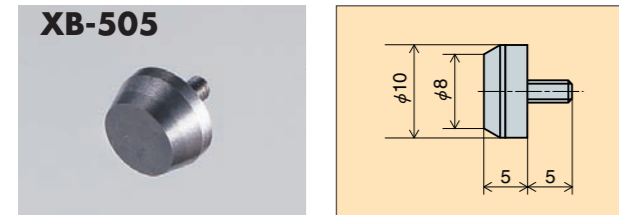

Part No.	Material
XB-505	Carbide

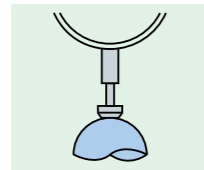

● Needle Type Contact Point

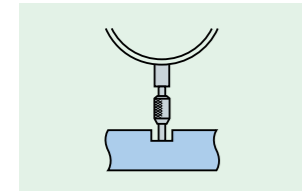
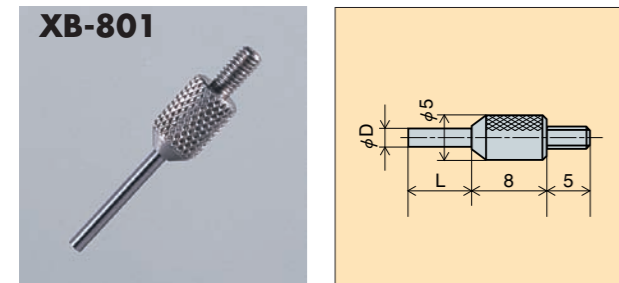

● Carbide Flat Contact Point



Part No.	Material
XB-605	Carbide

● Carbide Knife-edge Contact Point

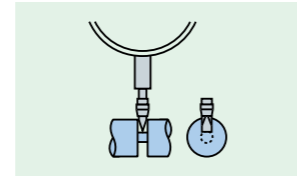
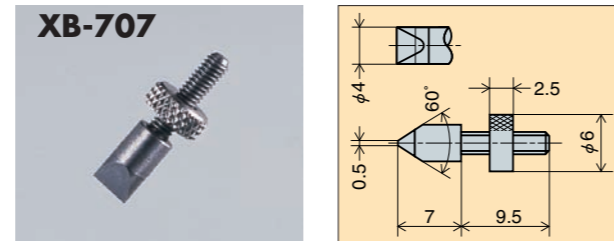

Part No.	Material
XB-707	Carbide

● Carbide Plain Contact Point

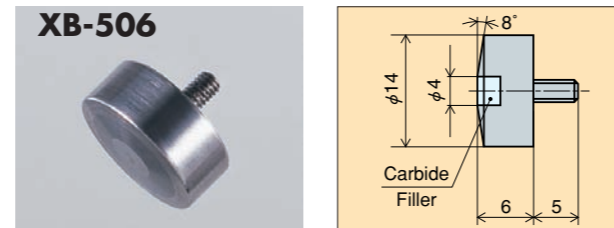

Part No.	Material
XB-506	Carbide

Part No.	φ D (mm)	L (mm)	Material
XB-800	1	2	Carbide
XB-801	1.5	12	Carbide
XB-802	2	7	Carbide
XB-803	2	12	Carbide
XB-804	1	20	Carbide
XB-805	1.5	20	Carbide
XB-806	2	20	Carbide
XB-807	1	40	Carbide
XB-808	1.5	40	Carbide
XB-809	2	40	Carbide

Part No.	φ D (mm)	L (mm)	Material
XS-800	1	2	SKS3
XS-801	1.5	12	SKS3
XS-802	2	7	SKS3
XS-803	2	12	SKS3
XS-804	1	20	SKH
XS-805	1.5	20	SKH
XS-806	2	20	SKH
XS-807	1	40	SKH
XS-808	1.5	40	SKH
XS-809	2	40	SKH

Replaceable Contact Point (Screw pitch M2.5 × 0.45mm)

for Dial Indicators and Linear Gauges

● Needle Contact Point

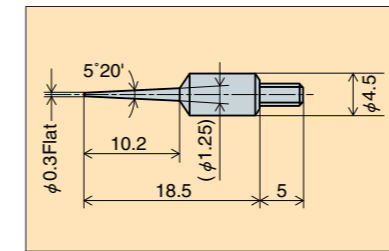

Part No.	Material
XT-2C	SK 3

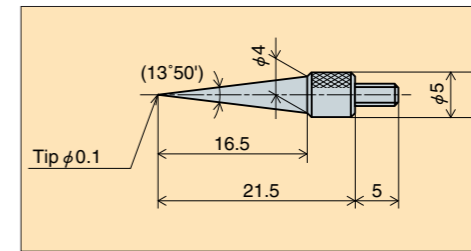

Part No.	Material
XT-3	SK 3

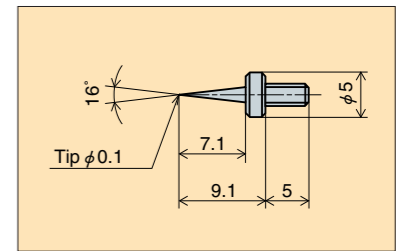

Part No.	Material
XT-4	SK 3

● Needle Contact Point

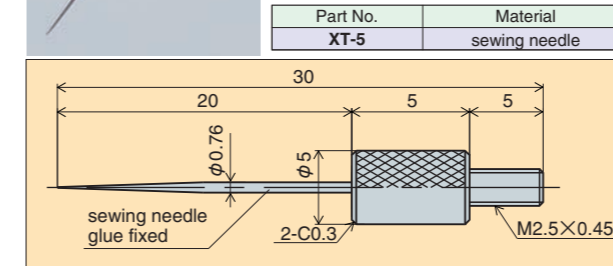
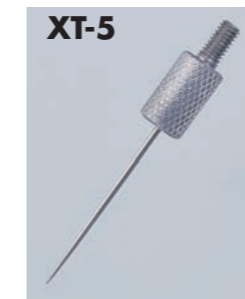

Part No.	Material
XT-5	sewing needle

● Roller Contact Point

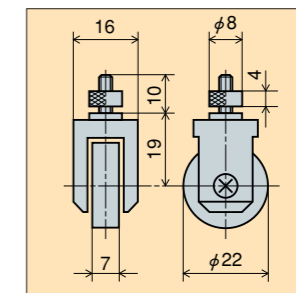

Part No.	Material
SH-1	SUJ2

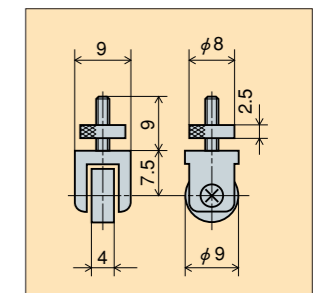

Part No.	Material
SH-2	SUJ2

● Contact Point Joint

To extend the contact point, simply add the contact point joint.

L (mm)	φ 4 type	φ 5 type
6	XJ-406	
10	XJ-410	XJ-510
15	XJ-415	
20	XJ-420	XJ-520
25	XJ-425	
30	XJ-430	XJ-530
35	XJ-435	
40	XJ-440	XJ-540
45	XJ-445	
50	XJ-450	XJ-550
55	XJ-455	
60	XJ-460	XJ-560
65	XJ-465	
70	XJ-470	
75	XJ-475	
80	XJ-480	
90	XJ-490	
100	XJ-400	

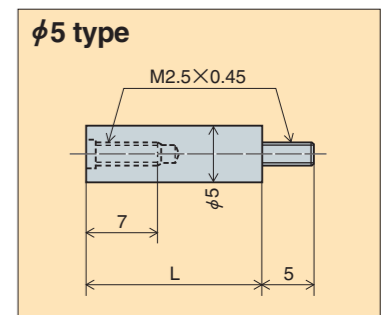
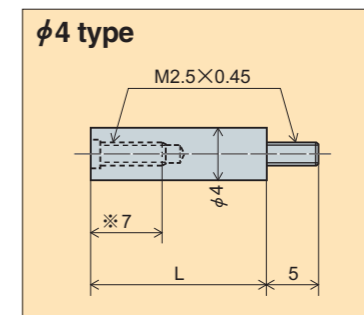

※Length of the thread screw of XJ-406 is 5mm.

Replaceable Contact Point

Replaceable Contact Point

Dimensions of Dial Gauges

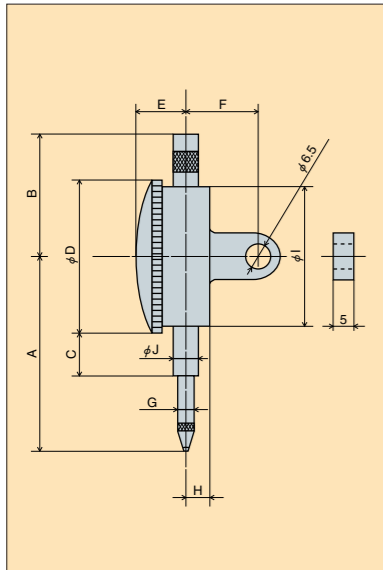

Standard 0.001mm 0.005mm (mm)

Model	A	B	C	D	E	F	G	H	I	J
5B-HG	60	41.5	18.5	53	14.5	20	4	6.5	49	8.0 ⁰ _{-0.022}
5-DX	60	42.6	17	55.7	14.5	20	5	7	52	8.0 ⁰ _{-0.03}
5B	60	41.5	18.5	53	14.5	20	4	6.5	49	8.0 ⁰ _{-0.022}
5F	60	41.5	18.5	53	14.5	—	4	6.5	49	8.0 ⁰ _{-0.022}
5-SWF	63	41.5	17.5	55	15	20	4	6.5	49	8.0 ⁰ _{-0.022}
25	72	42	25	66.5	14.5	20	4	7.5	62.5	8.0 ⁰ _{-0.03}
25F-RE	72	41	25	66.5	14.5	—	4	7.5	62.5	8.0 ⁰ _{-0.03}
25S	60	42.6	17	55.7	14.5	20	5	7	52	8.0 ⁰ _{-0.03}
55	73	52	25	66	17	20	4.5	7	62.5	8.0 ⁰ _{-0.03}
55-DX	62	44.5	17	57	17	19.5	4.5	6.5	52	8.0 ⁰ _{-0.03}
56	62	44.5	17	57	17	19.5	4.5	6.5	52	8.0 ⁰ _{-0.03}

Standard 0.01mm (mm)

Model	A	B	C	D	E	F	G	H	I	J
107-HG	65	41.5	18.5	53	14.5	20	4	6.5	49	8.0 ⁰ _{-0.03}
107-DX	65	50.7	17	55.7	14.5	20	5	7	52	8.0 ⁰ _{-0.03}
107	65	41.5	18.5	53	14.5	20	4	6.5	49	8.0 ⁰ _{-0.03}
107F	65	41.5	18.5	53	14.5	—	4	6.5	49	8.0 ⁰ _{-0.03}
107-SWA	68	41.5	17.5	55	15	20	4	6.5	49	8.0 ⁰ _{-0.03}
107-BL	65	41.5	18.5	53	14.5	—	4	6.5	49	8.0 ⁰ _{-0.03}
107F-RE	65	41.5	18.5	53	14.5	20	4	6.5	49	8.0 ⁰ _{-0.03}
107-LL	65	—	18.5	53	14.5	20	4	6.5	49	8.0 ⁰ _{-0.03}
107W	65	41.5	17.5	55	17	20	4	6.5	49	8.0 ⁰ _{-0.03}
107F-T	65	41.5	18.5	53	14.5	—	4	6.5	49	8.0 ⁰ _{-0.03}
107-E	65	41.5	18.5	53	14.5	20	4	6.5	49	8.0 ⁰ _{-0.03}
17	65	41.5	18.5	53	14.5	20	4	6.5	49	8.0 ⁰ _{-0.03}
57-SWA	65	41.5	18.5	55	15	20	4	6.5	49	8.0 ⁰ _{-0.03}
57	65	41.5	18.5	53	14.5	20	4	6.5	49	8.0 ⁰ _{-0.03}
57F	65	41.5	18.5	53	14.5	—	4	6.5	49	8.0 ⁰ _{-0.03}
57B	65	41.5	18.5	53	14.5	—	4	6.5	49	8.0 ⁰ _{-0.03}

Long Travel 0.01mm 0.005mm 0.1mm (mm)

Model	A	B	C	D	E	F	G	H	I	J
207	90	41	25	66.5	14.5	20	5	7.5	62.5	8.0 ⁰ _{-0.03}
207F-PL	90	41	25	66.5	14.5	—	5	7.5	62.5	8.0 ⁰ _{-0.03}
207F-T	90	41	25	66.5	14.5	—	5	7.5	62.5	8.0 ⁰ _{-0.03}
207S-LL	75	50.5	18.5	53	14.5	20	4	6.5	49	8.0 ⁰ _{-0.03}
207S	75	50.5	18.5	53	14.5	20	4	6.5	49	8.0 ⁰ _{-0.03}
207W	75	50.5	17.5	55	17	20	4	6.5	49	8.0 ⁰ _{-0.03}
207WF-T	75	50.5	17.5	55	17	—	4	6.5	49	8.0 ⁰ _{-0.03}
307S	107	89	22	57	17.5	20	5	7	52	8.0 ⁰ _{-0.03}
307	102	46	22.8	75.5	17.5	21	5	8	72.5	8.0 ⁰ _{-0.03}
507	128	81.5	26.7	81.5	17.5	21.5	5.5	8.5	78.5	10.0 ⁰ _{-0.03}
509	128	81.5	26.7	81.5	17.5	21.5	5.5	8.5	78.5	10.0 ⁰ _{-0.03}
809	201.5	86.5	54	112	24	22.5	6	10	108	14.0 ⁰ _{-0.03}

Miniature 0.01mm 0.005mm (mm)

Model	A	B	C	D	E	F	G	H	I	J
5S	43.2	30.5	12.9	40.8	12.5	—	4	5.1	37	8.0 ⁰ _{-0.03}
47	39.6	20	9.7	36	13	15	3.5	5.8	32	8.0 ⁰ _{-0.03}
47F	39.6	20	9.7	36	13	—	3.5	5.8	32	8.0 ⁰ _{-0.03}
57S	41.3	27.4	10	39	14	19	4	5.1	36.5	8.0 ⁰ _{-0.03}
36A	46.2	30.5	12.9	40.8	12.5	19	4	5.1	37	8.0 ⁰ _{-0.03}
36B	46.2	30.5	12.9	40.8	12.5	19	4	5.1	37	8.0 ⁰ _{-0.03}

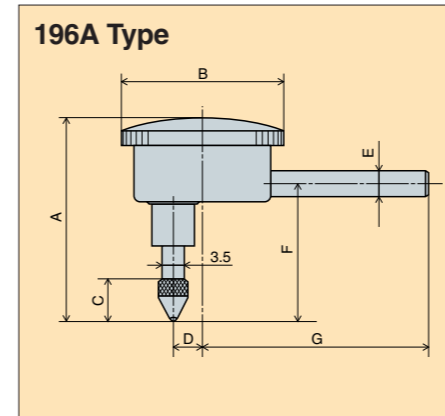

Back Plunger 0.01mm (mm)

Model	A	B	C	D	E	F	G
196A	44	38	9	4.5	6.35	28.1	57
196A-6	44	38	9	4.5	6	28.1	57

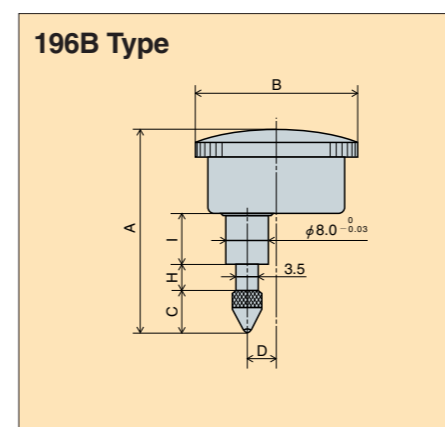

Back Plunger 0.01mm (mm)

Model	A	B	C	D	E	F	G	H	I
196B	58.5	38	12.5	4.5	—	—	—	5.5	16.5
196B-T	58.5	38	12.5	4.5	—	—	—	5.5	16.5
196Z	58.5	38	12.5	4.5	—	—	—	5.5	16.5

Accessories for Dial Gauges

● Outer dial plates

0.001mm type

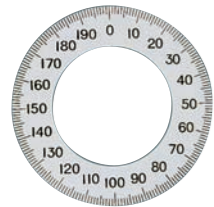

Continuous Dial A
(0-100-200)

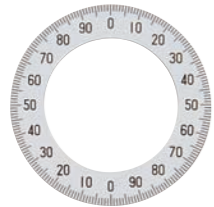

Continuous Dial B
(0-100-100)



Balanced dial
(0-100-0)

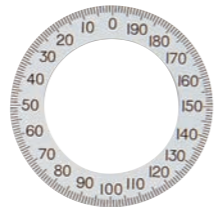

Reversed dial A
(±200-100-0)

0.01mm type

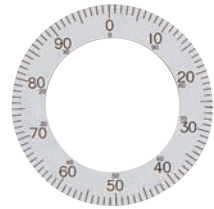

Continuous Dial A
(0-50-100)

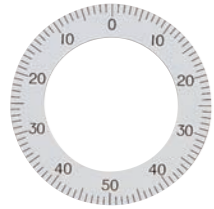

Balanced dial
(0-50-0)

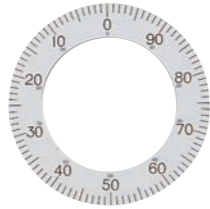

Reversed dial A
(±100-50-0)

● Color Caps



To manage the measurement by dial gauges, caps with five different colors are available. They are attachable to standard dial gauges. (No. 5, 107, 15, 17, 18, 55, 56 and 25S)

● Spindle Lifting Lever (LL-1)



Part No.	Dial Gauge installable
LL-1	107. 107F. 57. 57B. 57F. 17. 17B. 207S. 5B. 5F. 55. 55DX. 25S. 56. 17Z. 15Z. 107W

● Spindle pull-up Release

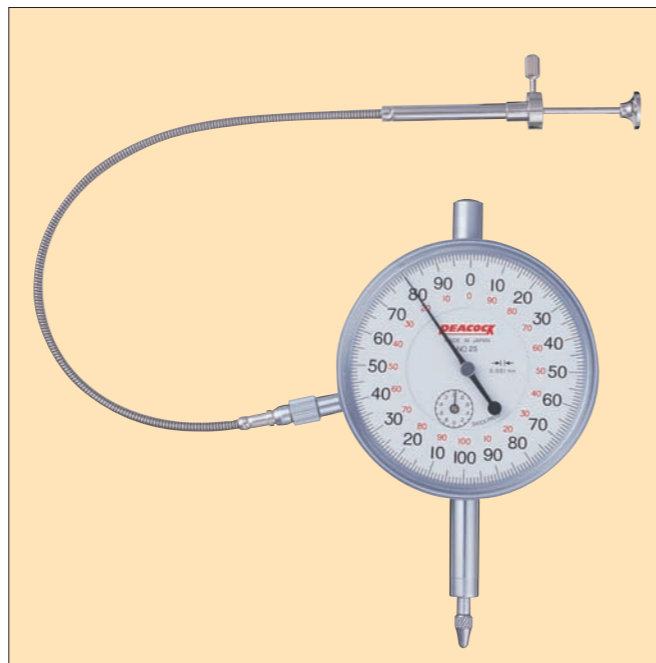

Part No.	Dial Gauge installable
RE-1 (Total length:275mm)	107F-RE. R1-B.
RE-2 (Total length:287mm)	25F-RE. R1-A.

(Applicable Models)

- 5B-HG, 5B, 5F, 5-SWF
- We can manufacture outer dials for other 0.001mm dial indicators. (examples: 25, 55, 55-DX)
 - We can manufacture outer dials with counter clock wise numbering.

(Applicable Models)

- 107-HG, 107, 107F, 107-SWA, 107-BL, 107F-RE, 107-LL, 17, 57-SWA, 57, 57F.
- We can manufacture outer dials for other 0.01mm dial indicators. (examples: 47, 57S, 36B)

● Various accessories

● Easily attachable adhesive limits A type



● Examples of adhesive limits stickers

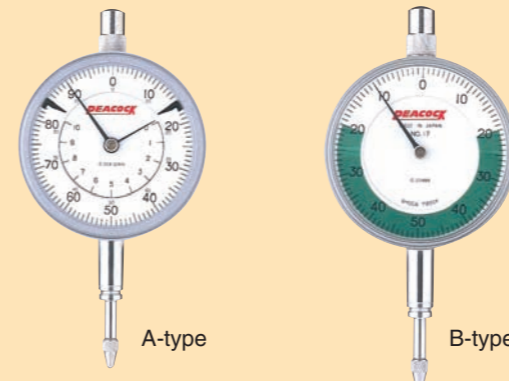

● Easily attachable adhesive limits B type

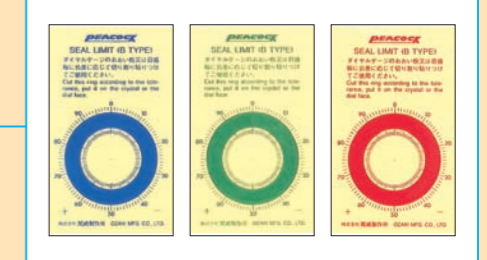

● Color caps



● Spindle Lifting Lever (LL-1)

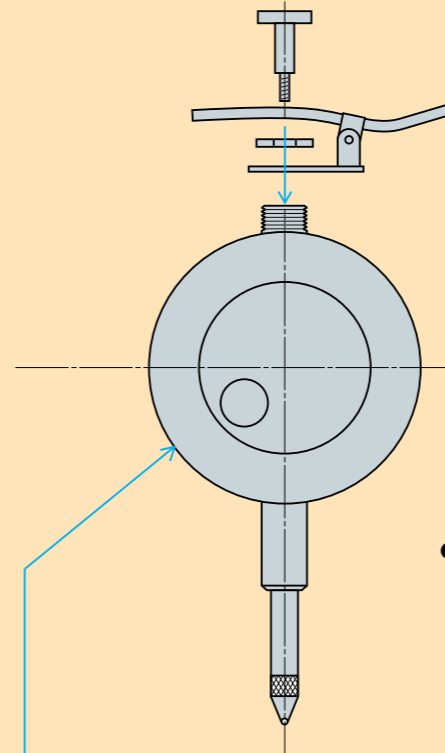

● Backs

● Contact point joint

● Replaceable contact points

● Outer dial plates



● Backs

The method of holding the dial gauge comes in two types; holding the stem and holding the lug of the back. However, the back may be replaced for convenience of holding.

1 Center lug back



GB-1A

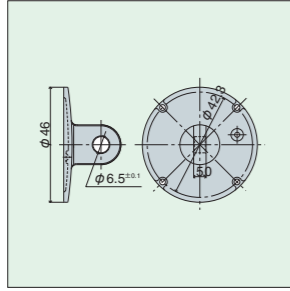

Part No.	Outer dia.	Dial Gauge installable
GB-1A	46.0	107. 107Z. 17Z. 57. 17. 17B. 5Z. 15Z. 207S. 207W. 18. 5B
GB-125	59.5	25. 55. 207
GB-1307	69.8	307
GB-1507	76.7	507. 509
GB-1809	105.0	809
GB-147	30.7	47. 47Z. 47SZ
GB-136	35.8	5S. 36A. 36B
GB-157S	35.3	57S
GB-1DX	50.2	55DX. 56. 107DX. 307S. 25S

2 Flat back



GB-3A

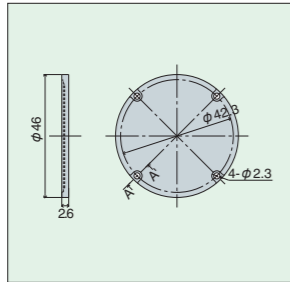

GB-3A	46.0	107. 107Z. 17Z. 57. 17. 17B. 5Z. 15Z. 207S. 207W. 18. 5B
GB-325	59.5	25. 207. 55
GB-3307	69.8	307
GB-3507	76.7	507. 509
GB-3809	105.0	809
GB-347	30.7	47. 47SZ. 47Z
GB-336	35.8	5S. 36A. 36B
GB-357S	35.3	57S
GB-3DX	50.2	55DX. 56. 107DX. 307S. 25S

3 Post back

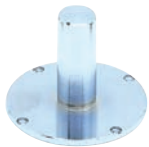

GB-4A

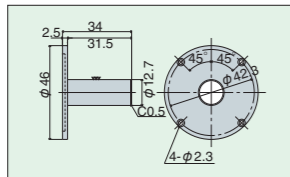

GB-4A	46.0	107. 107Z. 17Z. 57. 17. 17B. 5Z. 15Z. 207S. 207W. 18. 5B
GB-447	30.7	47. 47Z. 47SZ

4 Screw back

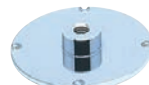

GB-5A

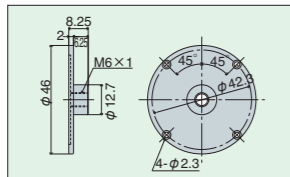

GB-5A	46.0	107. 107Z. 57. 17. 5B. 5Z. 17B. 15Z. 207S. 207W. 18
GB-547	30.7	47. 47Z. 47SZ
GB-536	35.8	5S. 36A. 36B
GB-557S	35.3	57S

5 Adjustable back



GB-6A

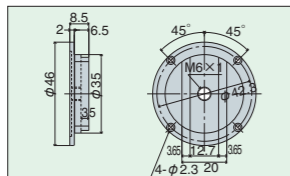

GB-6A	46.0	107. 107Z. 57. 17. 5B. 5Z.
GB-625	59.5	25. 55. 207
GB-647	30.7	47. 47Z. 47SZ
GB-636	35.8	5S. 36A. 36B
GB-657S	35.3	57S

6 Lug back with lever





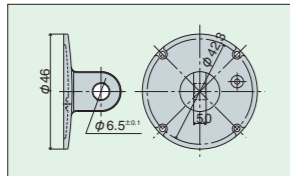









GB-7A

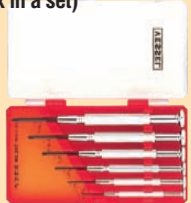

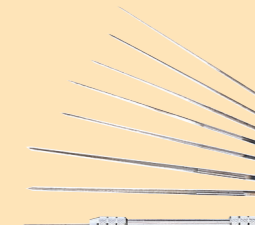
GB-7A	46.0	107. 107Z. 57. 17. 5B. 5Z. 17B. 15Z. 17Z. 18. 207S
-------	------	----------------------------------------------------

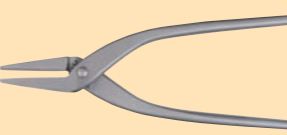
Repair Tools

● The tools in the table below are available either in a set or individually.

<p>1 Case</p>  <p>Width × Depth × Height 225mm × 180mm × 170mm</p>	<p>2 Pointer drawer</p>  <p>This is used to draw out a pointer. Insert the tip of this tool under the pointer, and push the spindle center with thread. The pointer can be drawn out easily. In this case, the center of pointer drawer should match with the spindle center.</p> <p>example </p>	<p>3 Hand drawer</p>  <p>This is used to draw out a hand of gauge. Extend a piece of thin paper between the hand and the dial face. Insert the tip of the tool under the hand, and draw it out in accordance with the principles of the lever.</p>	<p>4 Plus and minus driver set (six in a set)</p>  <p>⊖ No.2 (1.4mmW) ⊖ No.5 (2.9mmW) ⊕ No.3 (2mmW) ⊕ No.0 (4mmW) ⊕ No.4 (2.4mmW) ⊕ No.1 (5mmW) Select a driver which is suitable for the width of thread head and that of the slot. In particular, please avoid fastening or loosening a large thread using a small driver.</p>
<p>5 Driver with handle</p>  <p>This is used to fasten a thread which may be, at first, fastened with small driver, but finally requires to be fastened sufficiently. (For example, fastening of attaching screw of bottom board.)</p>	<p>6 Reamer and reamer holder</p>  <p>This is used to enlarge holes for pointer, hand, or spindle center. Stand the reamer in a right angle with the plane, and bore the hole lightly, relaxing your finger as possible as you can.</p>	<p>7 Clock oil</p>  <p>This is an oil to be lubricated in the course of assembly.</p>	<p>8 Tweezers</p>  <p>This is used to handle small parts such as hair spring, pointer or small thread.</p>
<p>9 Pliers</p>  <p>This is used to fasten or loosen a pin or knock.</p>	<p>10 Washing brush</p>  <p>This is used to remove sticks such as old oil cake and dusts with washing.</p>	<p>11 Blower</p>  <p>This is used, in the course of assembly, to remove dusts stuck to the dial face and so on. When the brush at the tip is removed, this can be used as a pump to blow off dusts. Do not breathe upon the apparatus to blow off dusts.</p>	<p>12 Lubrication brush</p>  <p>This is used, in the course of assembly, to lubricate into the spindle center. Use care to lubricate only a small amount of oil.</p>
<p>13 Crystal press fitter</p>  <p>This is to replace crystals. Set a crystal on the pad. Then press the fitter from the above to reduce the outer diameter, and fit the crystal into the outer frame.</p> <ul style="list-style-type: none"> ● Cover plate installer is for pressing the cover plate into either the outer frame of a plunger-type dial indicator or a lever-type dial indicator. ● Includes 8 types of changeable frames. ● Changeable frame examples: <ul style="list-style-type: none"> ③ and ④: for lever-type dial indicators PC and PCN ④ and ⑤: for small dial indicators ⑥ and ⑦: for standard type 0.001mm and 0.01mm dial indicators ⑦ and ⑧: for long stroke dial indicators ● Changeable frame sizes (mm): <ul style="list-style-type: none"> ① φ 20 ② φ 21.5 ③ φ 24.5 ④ φ 30 ⑤ φ 33 ⑥ φ 36 ⑦ φ 40.5 ⑧ φ 43 			

Technical Data

Dial Indicators JIS B 7503: 1997 (Japan Industrial Standards)

Methods of measuring of performance

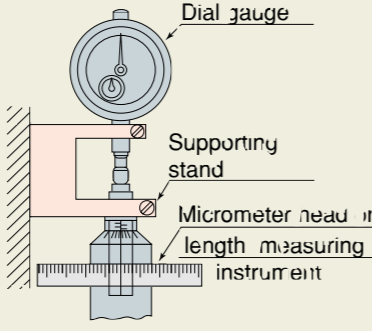
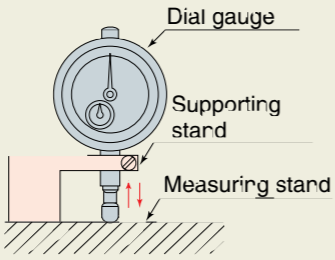
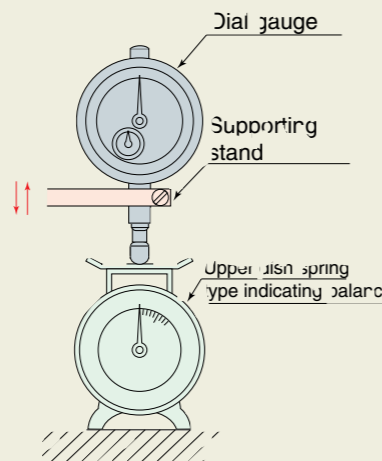
No.	Item	Measuring method	Illustration	Measuring instrument
1	Indication error	Holding the plunger of the dial gauge vertically and downward, carry out the following procedure setting the reading of dial gauge at the zero point.		Micrometer head or length measuring instrument of 0.5μm or under in scale interval and instrumental error of ±1μm and supporting stand for the dial gauge of 0.001mm and 0.002mm in scale interval and 2mm or under in measuring range.
2	Adjacent error	Press in the plunger 1/10 by 1/10 revolution up to two revolutions from the zero point, 1/2 by 1/2 revolution up to five revolutions and 1 by 1 revolution up to the end point of the measuring range after exceeding five revolutions and, returning back the plunger in the same state, read the same measuring points as in the pressing in direction. Obtain the error from the error diagram made as a result of the reading in both directions (see Attached Fig.1).		For other dial gauges from the above, micrometer head or length measuring instruments of 1μm or under in scale interval and ±1μm in instrumental error and measuring stand.
3	Retrace error	Pressing in direction. Obtain the error from the error diagram made as a result of the reading in both directions (see Attached Fig.1).		
4	Repeatability	Applying the contact point vertically on the upper surface of the measuring stand, obtain the maximum difference between the indications at every times when the plunger is operated rapidly and slowly five times at an arbitrary position in the measuring range.		Measuring stand. Supporting stand.
5	Measuring Force	Hold the dial gauge whose plunger is placed vertically and downward, transfer the plunger up-and-downward continuously and slowly to measure the measuring forces at the zero point, center and end point of the measuring range.		Supporting stand. Upper dish spring type indicating balance (2g or under in scale interval) or force meter (0.02 N or under in sensitivity).

Dial Indicators JIS B 7503: 1997 (Japan Industrial Standards)

Maximum allowable error of indication

(unit: μm)

Measuring range	Scale interval and measuring range					
	0.01mm	0.002mm		0.001mm		
Measuring range	10mm max.	2mm max.	Over 2mm, and less than 10mm	1mm max.	Over 1mm, and less than 2mm	Over 2mm, and less than 5mm
Retrace Error	5	3	4	3	3	4
Repeatability	5	0.5	1	0.5	0.5	1
Indication error	1/10 revolution (1)	8	4	5	2.5	4
	1/2 revolution	±9	±5	±6	±3	±5
	One revolution	±10	±6	±7	±4	±6
	Two revolutions	±15	±6	±8	±4	±6
	Whole measuring range	±15	±7	±12	±5	±7

Note: (1) Adjacent error.
Remark: The value in this table shall be at 20°C.

Indication error diagram

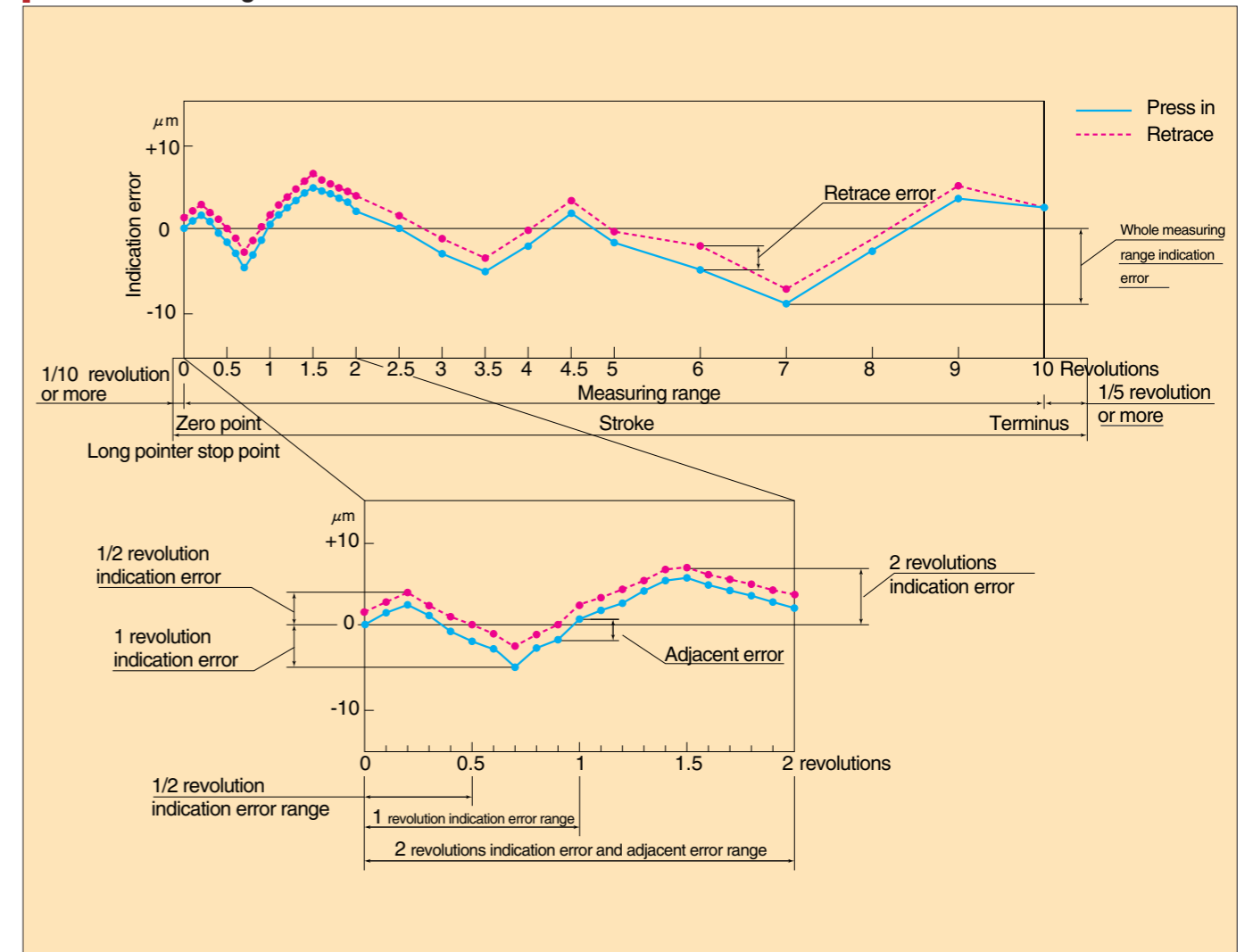

Technical Data

Technical Data

Marking Service

1

To all our valued customers :

When you purchase any new PEACOOK gauges from us, we now offer an optional value adding free making services of Control Numbers directly onto gauges for your ISO needs; any other control needs and for planned future needs.

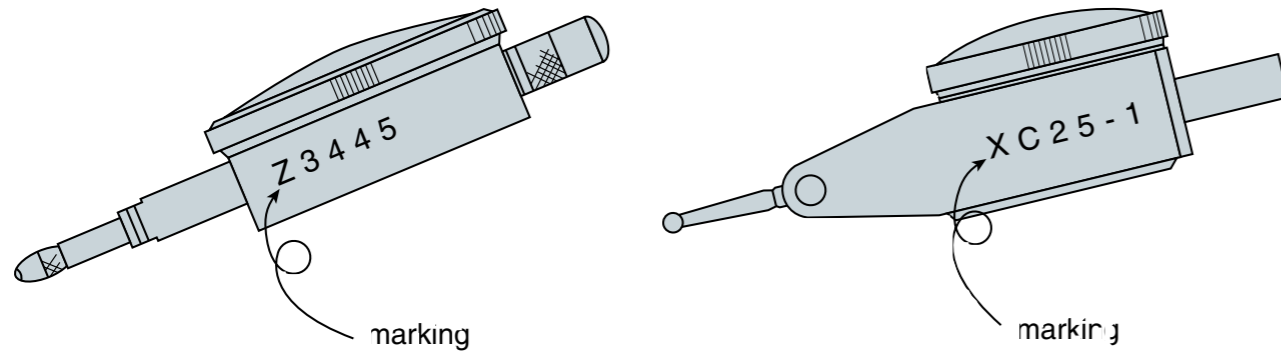

● Marking is made by an ultrasonic method.

Character size, spacing between characters and its direction can specifically be set under the following ranges :

Character size (height) — 1.0 to 10 mm

(at intervals of 0.1mm, at variable step)

max. 10 characters

Numbers of characters — • Alphabet-Capital letters (26)

Characters of making — A B C D E F X Y Z

• Alphabet-Small letters (26)

a b c d e f x y z

• Numeric characters (10)

0 1 2 3 4 5 6 7 8 9

• Symbols (18)

+ - × / ± = () < > [] ¥ : . , . .

• Standard font (Helvetica)

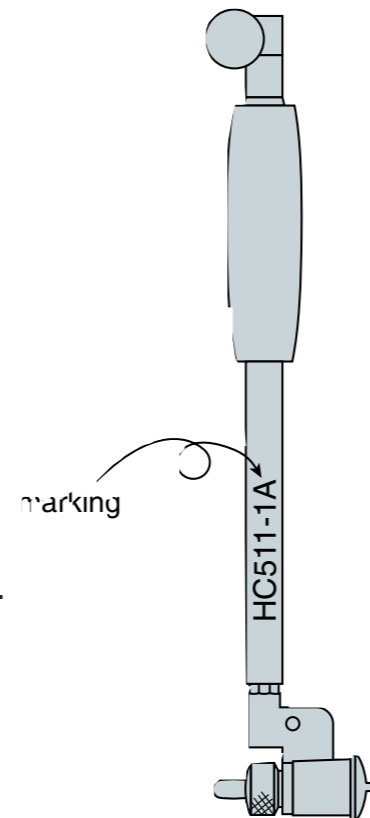

SECTION

2



2

Lever Type Dial Indicators Pic Test • New Pic Test

- PCN Series
- W Series
- Z Series
- E Series
- U Series
- D Series
- PC Series
- R Series **"NEW"**
- With 8mm Dovetail Stem Series **"NEW"**
- Accessories

Lever Type Dial Indicators NEW PIC TEST

Without change lever PCN series

The New Pic Test is a lever type dial indicators used in all over the world. It is a measuring instrument used for measurements of restricted areas, and the outside/inside, groove width and centering with the dial gauge installed to the lathe or the milling cutting machine for measurements with the gauges held on the height gauges.

- **Without change lever (Automatic inverse type)**
The lever type dial gauge of this type has no change lever, the contact point inverses automatically in normal or reverse direction as desired and pointer turns always CW to improve the measuring efficiency.
- **Miniature Bearing Used**
The miniature bearing used as a bearing at the pivot of the contact point to show good indication stability without any effect by rod play.
- **O-ring used**
Oil resistance is enhanced by seating the O-ring in the turning section of the outer frame.



PCN-0
Graduation: 0.01mm
Range: 0.5mm

- Small dial face (φ 29)



PCN-1A
Graduation: 0.01mm
Range: 0.5mm

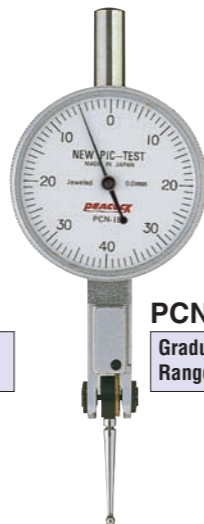

PCN-1B
Graduation: 0.01mm
Range: 0.8mm



PCN-1L
Graduation: 0.01mm
Range: 1.0mm

- Long contact point (L = 42.8mm)



PCN-2
Graduation: 0.002mm
Range: 0.28mm



PCN-2B
Graduation: 0.002mm
Range: 0.2mm



PCN-S
Graduation: 0.001mm
Range: 0.14mm

- High accuracy

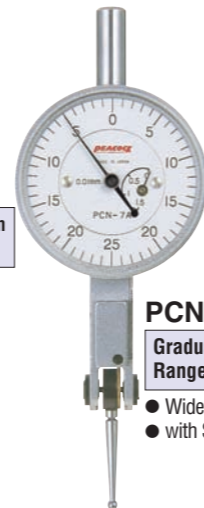

PCN-7A
Graduation: 0.01mm
Range: 1.5mm

- Wide measuring range
- with Shorter Pointer



PCN-7C
Graduation: 0.002mm
Range: 0.6mm

- Wide measuring range
- with Shorter Pointer

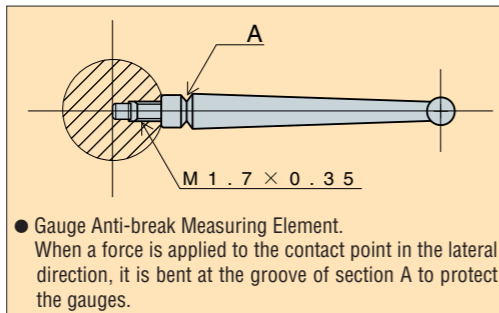

※ The contact point can simply replaced (See page P57).



PCN-5
Graduation: 0.01mm
Range: 0.5mm



PCN-6
Graduation: 0.002mm
Range: 0.28mm



PCN-6S
Graduation: 0.001mm
Range: 0.14mm

Specifications

Model	Graduation (mm)	Range (mm)	Reading	Accuracy (μm)			Measuring force less than(N)
				Wide-range forward accuracy	Adjacent error	Backward error	
PCN-0	0.01	0.5	0 - 25 - 0	5	5	3	0.3
PCN-1A	0.01	0.5	0 - 25 - 0	5	5	3	0.3
PCN-1B	0.01	0.8	0 - 40 - 0	8	5	3	0.3
PCN-1L	0.01	1.0	0 - 50 - 0	10	5	4	0.3
PCN-2	0.002	0.28	0 - 140 - 0	3	2	2	0.3
PCN-2B	0.002	0.2	0 - 100 - 0	3	2	2	0.3
PCN-S	0.001	0.14	0 - 70 - 0	3	2	2	0.3
PCN-7A	0.01	1.5	0 - 25 - 0	8	5	3	0.3
PCN-7C	0.002	0.6	0 - 100 - 0	6	2	3	0.3
PCN-5	0.01	0.5	0 - 25 - 0	5	5	3	0.3
PCN-6	0.002	0.28	0 - 140 - 0	3	2	2	0.3
PCN-6S	0.001	0.14	0 - 70 - 0	3	2	2	0.3

New

Special Type Test Indicators

Double Dial Type W series

- The conventional lever type dial gauge used to have some unreadable points when aligning with it, which has made it impossible to do the accurate aligning till now. The double dial type Pic Test has two dials at both sides, making it possible to cover said unreadable points by conventional Pic Tests.



PC-1BW
Graduation: 0.01mm
Range: 0.8mm

- Change lever type

Alignment work

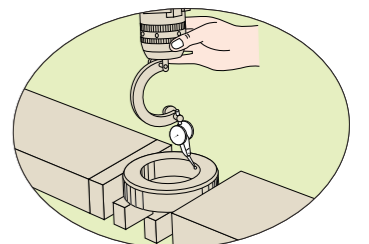

With Dual dial type, readings can be made easily even if gauges is turned 180 deg.

Specifications

Model	Graduation (mm)	Range (mm)	Reading	Accuracy (μm)			Measuring force less than(N)
				Wide-range forward accuracy	Adjacent error	Backward error	
PC-1BW	0.01	0.8	0 - 40 - 0	8	5	4	0.4

Special Type Test Indicators

One Revolution Z series (without change lever type)

The dial face is easy to read with light yellow and blue (dead zone)

- Gauge Anti-break Measuring Element**
When a force is applied to the contact point in the lateral direction, it is bent at the groove of section A to protect the gauge. The contact point can simply be replaced (adopted in all the PCN and PC).
- Dial face with colored limit**
To check out of tolerance detection and testing easier.
- Dust and Oil resistant O-ring (inside bezel)**
Oil resistance is enhanced by seating the O-ring in the turning section of the outer frame.
- Super sensitive miniature bearing used**
The miniature bearing is used as a bearing at the pivot of the contact point to show stable indication without any effect by rod play.
- No clutch (automatic inverse type)**
The Pic Test Indicator of this type has no bias lever, the contact point inverse automatically in the normal or reverse direction as desired and the pointer turns always CW to improve the measuring efficiency.
- φ6mm SK quenched stem**

"A" type Downward



PCN-1BZ(A)
Graduation: 0.01mm
Range: 0.6mm
● Contact point (XN1B-2) is attached



PCN-1LZ(A)
Graduation: 0.01mm
Range: 0.8mm
● Contact point (XN1L-2) is attached



PCN-2Z(A)
Graduation: 0.002mm
Range: 0.2mm
● High accuracy
● Contact point (XN2-2) is attached

Specifications

Model	Graduation (mm)	Range (mm)	Movable Range (mm)	Indication error			Measuring force less than(N)
				Whole measuring range	Adjacent error	Backward error	
PCN-1BZ(A)	0.01	0.6	0.7	8	5	3	0.3
PCN-1LZ(A)	0.01	0.8	0.9	10	5	4	0.3
PCN-2Z(A)	0.002	0.2	0.24	3	2	2	0.3

"B" type Upward



PCN-1BZ(B)
Graduation: 0.01mm
Range: 0.6mm
● Contact point (XN1B-2) is attached



PCN-1LZ(B)
Graduation: 0.01mm
Range: 0.8mm
● Contact point (XN1L-2) is attached



PCN-2Z(B)
Graduation: 0.002mm
Range: 0.2mm
● High accuracy
● Contact point (XN2-2) is attached

Specifications

Model	Graduation (mm)	Range (mm)	Movable Range (mm)	Indication error			Measuring force less than(N)
				Whole measuring range	Adjacent error	Backward error	
PCN-1BZ(B)	0.01	0.6	0.7	8	5	3	0.3
PCN-1LZ(B)	0.01	0.8	0.9	10	5	4	0.3
PCN-2Z(B)	0.002	0.2	0.24	3	2	2	0.3

Dimensions

● Length of Contact Point

Model	L (mm)
PCN-1BZ(A) PCN-1BZ(B)	22.2
PCN-2Z(A) PCN-2Z(B)	17.94
PCN-1LZ(A) PCN-1LZ(B)	42.8

Special Type Test Indicators

Super low measuring force E series

Lever dial gauge that is suitable for flaw-free measure of an object under measurement and for measurement of plastic products with a low measuring force.
A measuring force is 0.05N, 0.1N or less that is lower than a 0.4N measuring force in the conventional dial gauges.
Specifications and outer dimensions are the same as those of standard PC and PCN types, except a measuring force.

Without change lever type (CW rotation only)

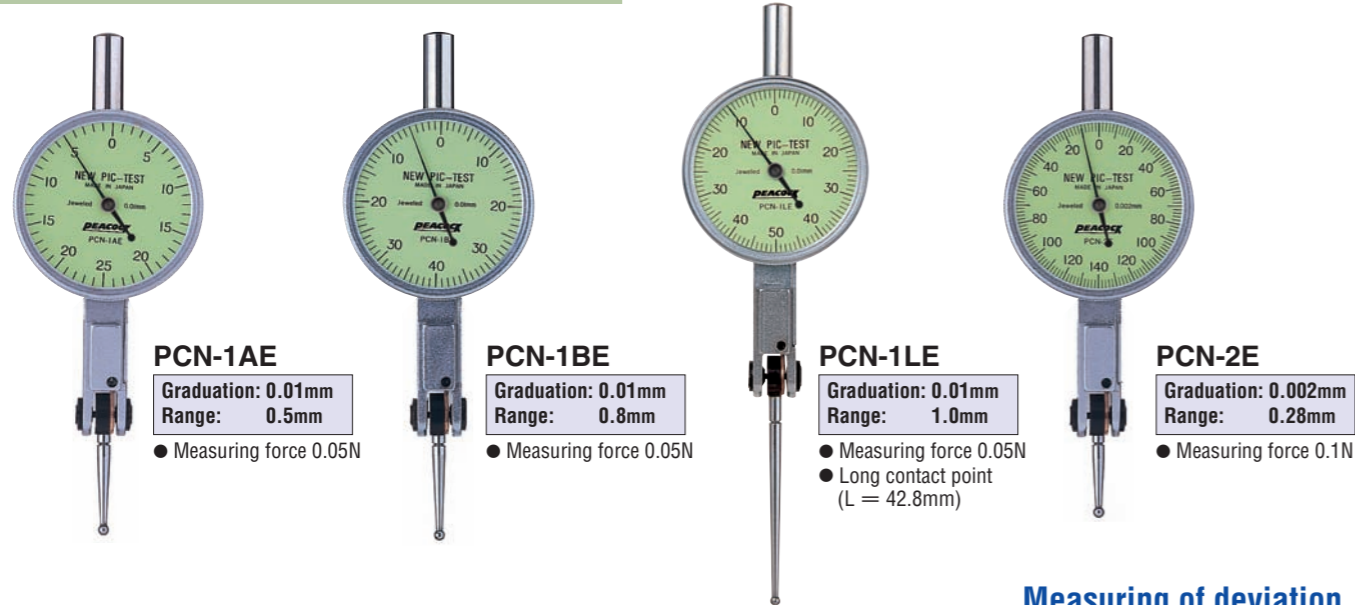

Change lever type

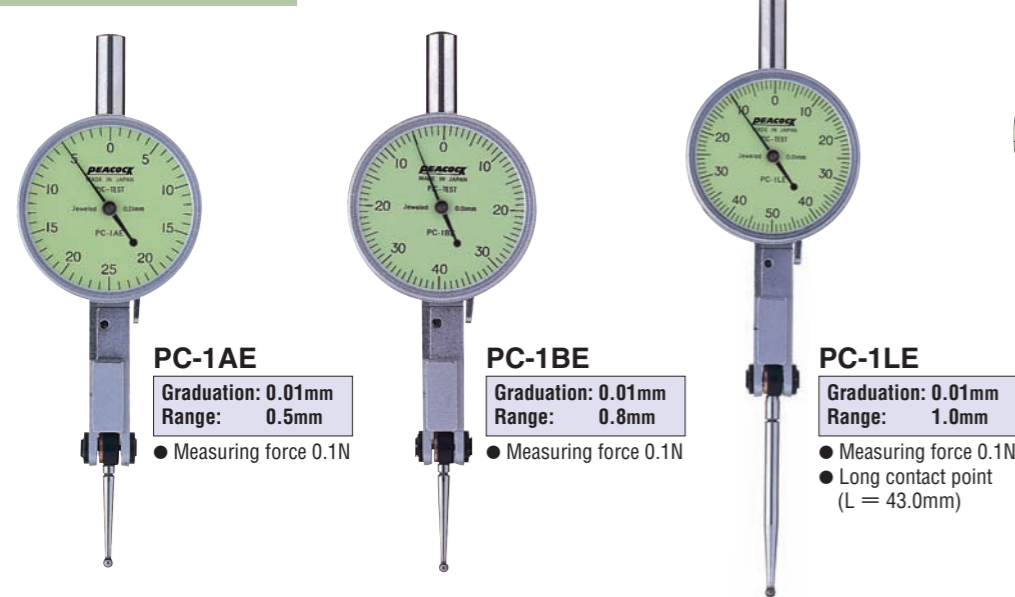

Measuring of deviation on rubber roller

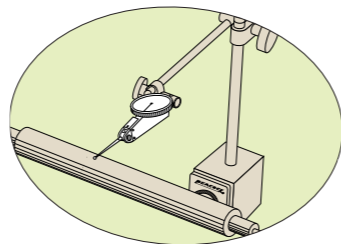

With extra low measuring force, work piece can be measured without deforming it.

Specifications

Model	Graduation (mm)	Range (mm)	Reading	Accuracy (μm)			Measuring force less than(N)
				Wide-range forward accuracy	Adjacent error	Backward error	
PCN-1AE	0.01	0.5	0 - 25 - 0	5	5	3	0.05
PCN-1BE	0.01	0.8	0 - 40 - 0	8	5	3	0.05
PCN-1LE	0.01	1.0	0 - 50 - 0	10	5	4	0.05
PCN-2E	0.002	0.28	0 - 140 - 0	3	2	2	0.1
PC-1AE	0.01	0.5	0 - 25 - 0	5	5	3	0.1
PC-1BE	0.01	0.8	0 - 40 - 0	8	5	3	0.1
PC-1LE	0.01	1.0	0 - 50 - 0	10	5	4	0.1

Special Type Test Indicators

Non-electrifying & Complete Anti-magnetic U series

When non-electrifying type of Pic Test or New Pic Test is used, electric flow is blocked at the ceramic stem, even of a magnetic stand is electrified. Thus, you can continue your work without any problem.

The dial face is light blue color and easy to read.
Specifications and outer dimensions are the same as those of standard PCN types, except the portion of stems.

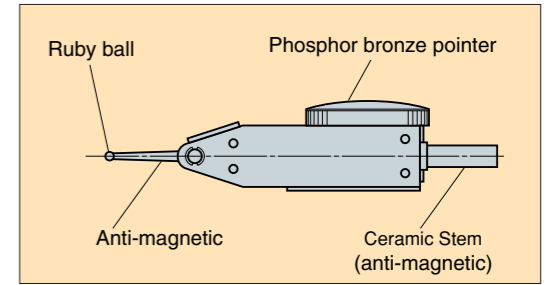

Without change lever type (CW rotation only)

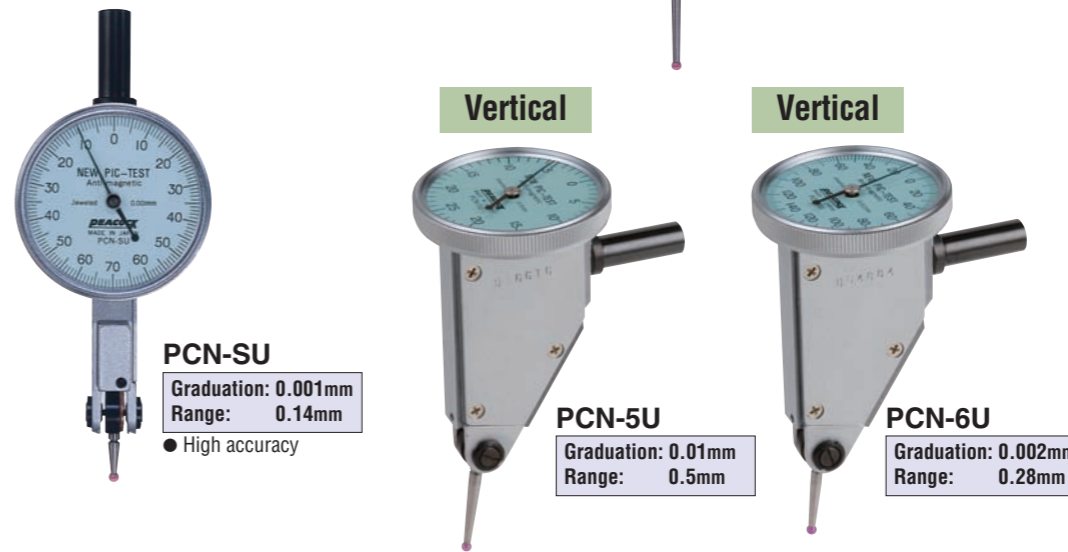
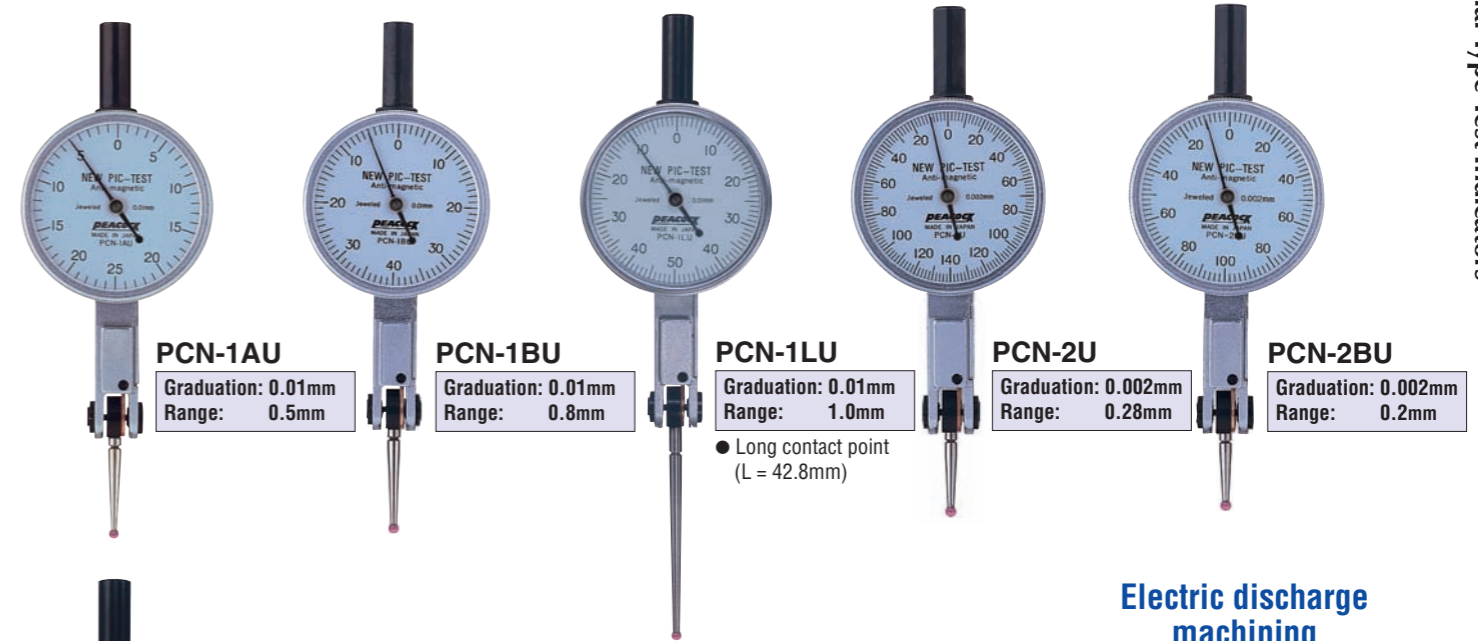

Electric discharge machining

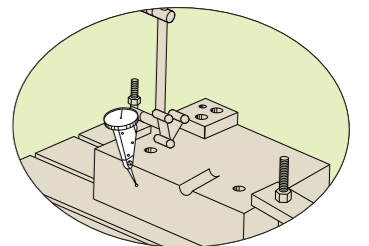

Ceramic stem is supported by a magnetic stand. Electric current is isolated by the ceramic stem. It is thus possible to measure the work piece without electrifying it.

Specifications

Model	Graduation (mm)	Range (mm)	Reading	Accuracy (μm)			Measuring force less than(N)
				Wide-range forward accuracy	Adjacent error	Backward error	
PCN-1AU	0.01	0.5	0 - 25 - 0	5	5	3	0.3
PCN-1BU	0.01	0.8	0 - 40 - 0	8	5	3	0.3
PCN-1LU	0.01	1.0	0 - 50 - 0	10	5	4	0.3
PCN-2U	0.002	0.28	0 - 140 - 0	3	2	2	0.3
PCN-2BU	0.002	0.2	0 - 100 - 0	3	2	2	0.3
PCN-SU	0.001	0.14	0 - 70 - 0	3	2	2	0.3
PCN-5U	0.01	0.5	0 - 25 - 0	5	5	3	0.3
PCN-6U	0.002	0.28	0 - 140 - 0	3	2	2	0.3

Special Type Test Indicators

Large dial face D series

The dial plate size of PCN-1A, PCN-1L, PCN-2B, and PCN-S models has been enlarged, with easy reading due to the larger scale spacing, as a result. Screw type long stems are standard for these large dial face test indicators.

Without change lever type (CW rotation only)



PCN-1AD
Graduation: 0.01mm
Range: 0.5mm

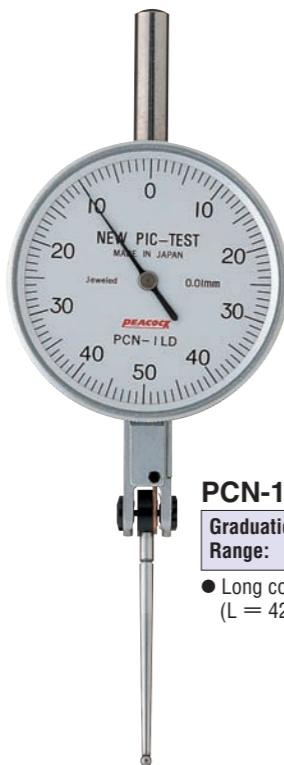

PCN-1LD
Graduation: 0.01mm
Range: 1mm
● Long contact point (L = 42.8mm)



PCN-2BD
Graduation: 0.002mm
Range: 0.2mm

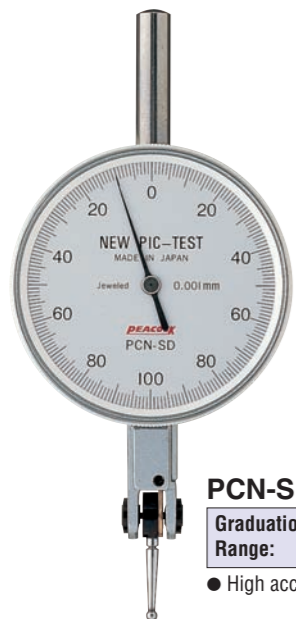

PCN-SD
Graduation: 0.001mm
Range: 0.2mm
● High accuracy

Easy to read

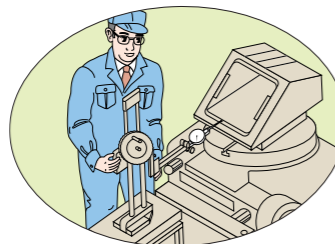

An enlarge dial face with bigger scale intervals enables easy reading by user of all ages.

Large Size Dial Face

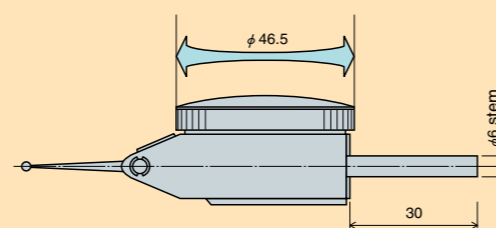

Specifications

Model	Graduation (mm)	Range (mm)	Reading	Accuracy (μm)			Measuring force less than(N)
				Wide-range forward accuracy	Adjacent error	Backward error	
PCN-1AD	0.01	0.5	0 - 25 - 0	5	5	3	0.3
PCN-1LD	0.01	1.0	0 - 50 - 0	10	5	4	0.3
PCN-2BD	0.002	0.2	0 - 100 - 0	3	2	2	0.3
PCN-SD	0.001	0.2	0 - 100 - 0	3	2	2	0.3

Lever Type Dial Indicators PIC TEST

Change lever type PC series

- Miniature Bearing Used
The miniature bearing used as a bearing at the pivot of the contact point to show good indication stability without any effect by rod play.
- O-ring used
Oil resistance is enhanced by seating the O-ring in the turning section of the outer frame.

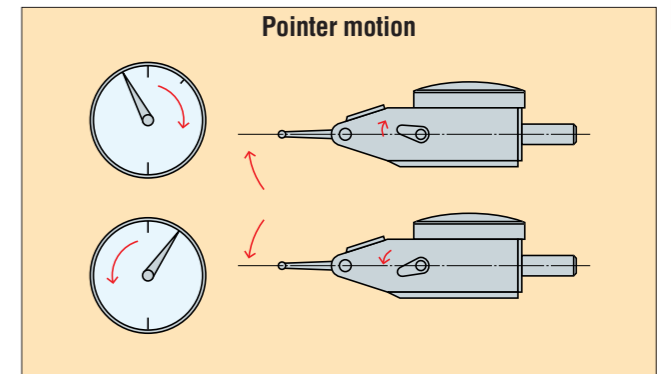

PC-1A
Graduation: 0.01mm
Range: 0.5mm



PC-1B
Graduation: 0.01mm
Range: 0.8mm

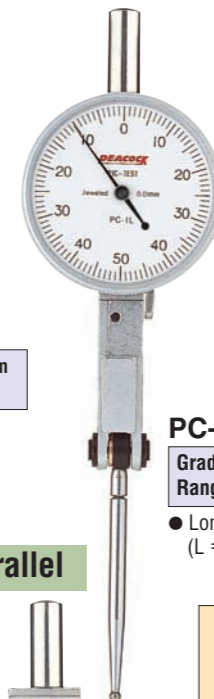

PC-1L
Graduation: 0.01mm
Range: 1.0mm
● Long contact point (L = 43.0mm)



PC-2
Graduation: 0.002mm
Range: 0.28mm



PC-3
Graduation: 0.01mm
Range: 0.5mm

Parallel
New



PC-3L
Graduation: 0.01mm
Range: 1.0mm
● Contact point (XPIL-2)

Parallel



PC-4
Graduation: 0.002mm
Range: 0.28mm

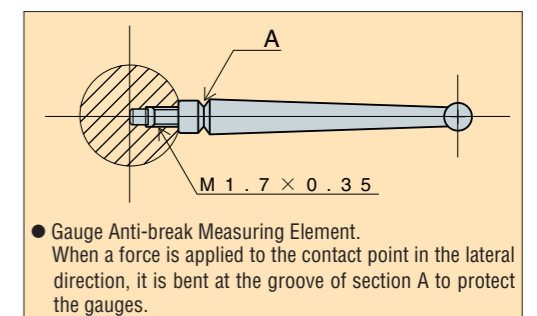

● Gauge Anti-break Measuring Element.
When a force is applied to the contact point in the lateral direction, it is bent at the groove of section A to protect the gauges.

※ The contact point can simply be replaced (See page P57).

Specifications

Model	Graduation (mm)	Range (mm)	Reading	Accuracy (μm)			Measuring force less than(N)
				Wide-range forward accuracy	Adjacent error	Backward error	
PC-1A	0.01	0.5	0 - 25 - 0	5	5	3	0.4
PC-1B	0.01	0.8	0 - 40 - 0	8	5	3	0.4
PC-1L	0.01	1.0	0 - 50 - 0	10	5	4	0.4
PC-2	0.002	0.28	0 - 140 - 0	3	2	2	0.4
PC-3	0.01	0.5	0 - 25 - 0	5	5	3	0.4
PC-3L	0.01	1.0	0 - 50 - 0	10	5	4	0.4
PC-4	0.002	0.28	0 - 140 - 0	3	2	2	0.4

PIC TEST/NEW PIC TEST PC · PCN New Lineup

PIC TEST/NEW PIC TEST with Ruby ball Contact Point "R" series (Contact Point ball dia. 2mm Only)

- Excellent wear resistance
- Non-electrifying and Anti-magnetic
- Can be used on Electrical Discharge Machine

Ruby ball Contact Point

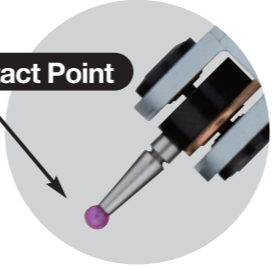

Horizontal



PC-1AR
Graduation: 0.01mm
Range: 0.5mm

- Change Lever type
- Contact Point XP1A-2R

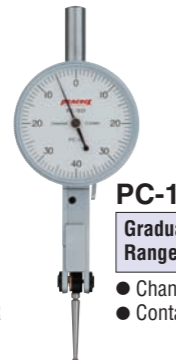

PC-1BR
Graduation: 0.01mm
Range: 0.8mm

- Change Lever type
- Contact Point XP1B-2R

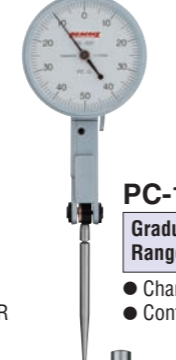

PC-1LR
Graduation: 0.01mm
Range: 1.0mm

- Change Lever type
- Contact Point XP1L-2R

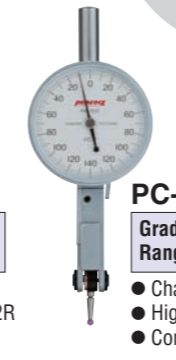

PC-2R
Graduation: 0.002mm
Range: 0.28mm

- Change Lever type
- High accuracy
- Contact Point XP2-2R



PCN-1AR
Graduation: 0.01mm
Range: 0.5mm

- Without Change Lever type
- Contact Point XN1A-2R

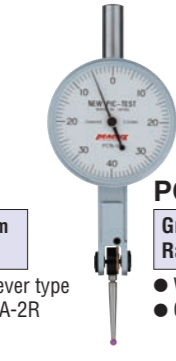

PCN-1BR
Graduation: 0.01mm
Range: 0.8mm

- Without Change Lever type
- Contact Point XN1B-2R

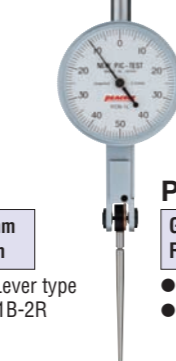

PCN-1LR
Graduation: 0.01mm
Range: 1.0mm

- Without Change Lever type
- Contact Point XN1L-2R

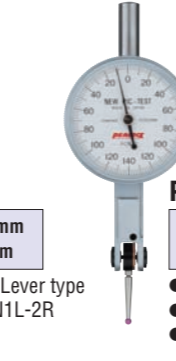

PCN-2R
Graduation: 0.002mm
Range: 0.28mm

- Without Change Lever type
- High accuracy
- Contact Point XN2-2R



PCN-2BR
Graduation: 0.002mm
Range: 0.2mm

- Without Change Lever type
- High accuracy
- Contact Point XN2B-2R



PCN-SR
Graduation: 0.001mm
Range: 0.14mm

- Without Change Lever type
- High accuracy
- Contact Point XNS-2R



PCN-5R
Graduation: 0.01mm
Range: 0.5mm

- Without Change Lever type
- Contact Point XN1A-2R

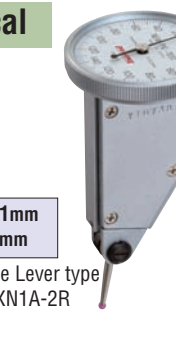

PCN-6R
Graduation: 0.002mm
Range: 0.28mm

- Without Change Lever type
- High accuracy
- Contact Point XN2-2R

Vertical

Specifications

Model	Graduation (mm)	Range (mm)	Reading	Accuracy (μm)			Measuring force less than(N)
				Wide-range forward accuracy	Adjacent error	Backward error	
PC-1AR	0.01	0.5	0 - 25 - 0	5	5	3	0.4
PC-1BR	0.01	0.8	0 - 40 - 0	8	5	3	0.4
PC-1LR	0.01	1.0	0 - 50 - 0	10	5	4	0.4
PC-2R	0.002	0.28	0 - 140 - 0	3	2	2	0.4
PCN-1AR	0.01	0.5	0 - 25 - 0	5	5	3	0.3
PCN-1BR	0.01	0.8	0 - 40 - 0	8	5	3	0.3
PCN-1LR	0.01	1.0	0 - 50 - 0	10	5	4	0.3
PCN-2R	0.002	0.28	0 - 140 - 0	3	2	2	0.3
PCN-2BR	0.002	0.2	0 - 100 - 0	3	2	2	0.3
PCN-SR	0.001	0.14	0 - 70 - 0	3	2	2	0.3
PCN-5R	0.01	0.5	0 - 25 - 0	5	5	3	0.3
PCN-6R	0.002	0.28	0 - 140 - 0	3	2	2	0.3

News

"DS8V" series

- We can provide all of our PIC TEST/NEW PIC TEST with φ 8mm Dovetail Stem to meet with your holding device.
(except Model PC-1BW, PC-1LW)





PC-1B-DS8V
Graduation: 0.01mm
Range: 0.8mm



PC-1L-DS8V
Graduation: 0.01mm
Range: 1.0mm



PC-4-DS8V
Graduation: 0.002mm
Range: 0.28mm



PCN-1B-DS8V
Graduation: 0.01mm
Range: 0.8mm



PCN-2-DS8V
Graduation: 0.002mm
Range: 0.28mm



PCN-S-DS8V
Graduation: 0.001mm
Range: 0.14mm

Set in Cass



Example
Devetail A. B. C

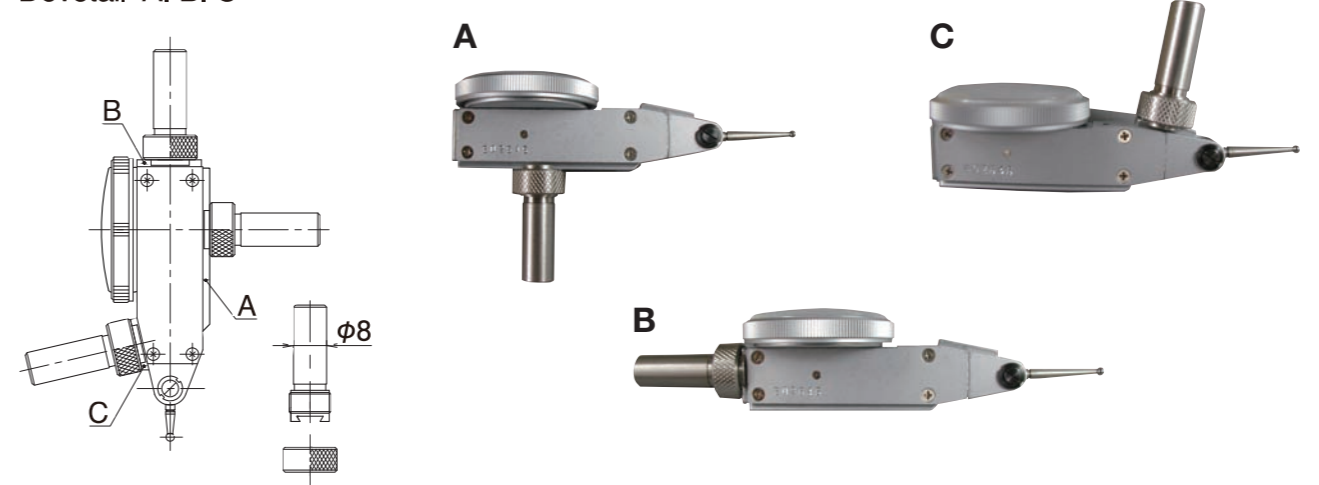

Special Type Test Indicators

Special Type Test Indicators

Accessories (Option)

● Replaceable contact point (carbide ball)



● Pic test holder

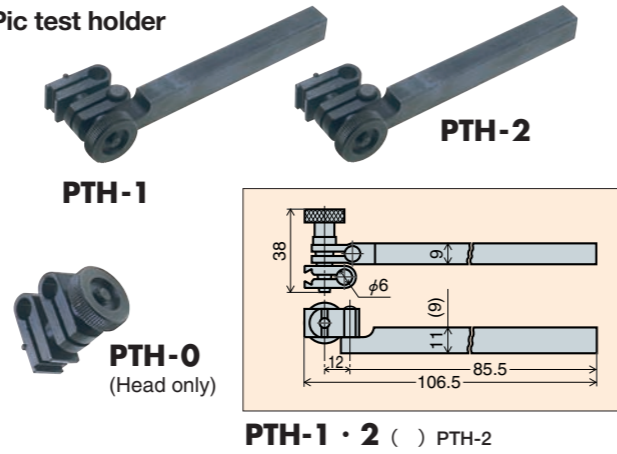

● Universal holder

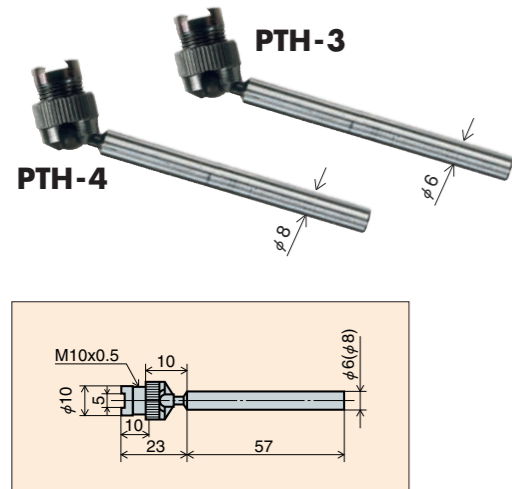

● Centricator (Pic Test Indicators supplied on request)

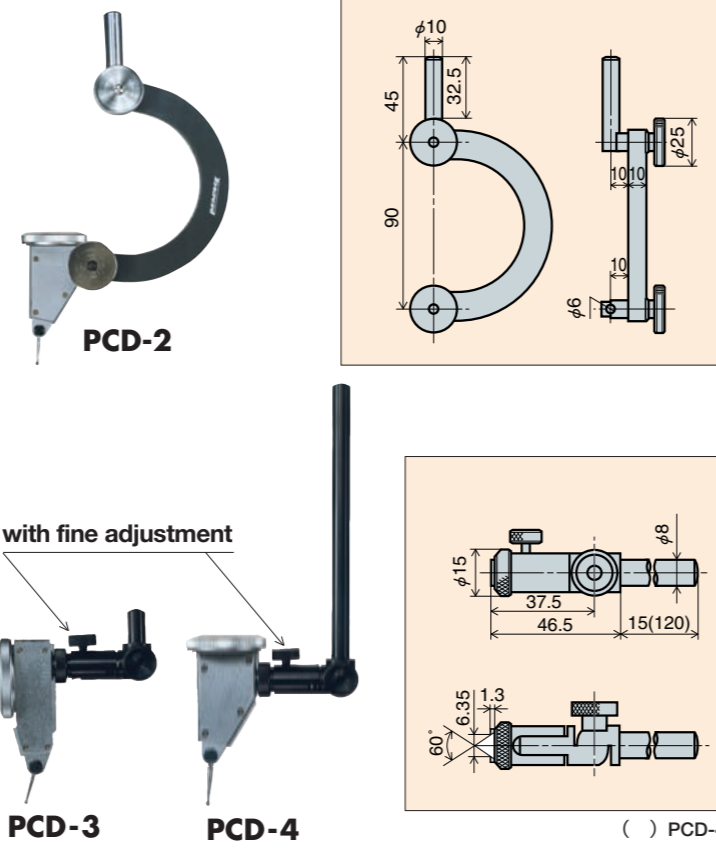

● Dovetail stem

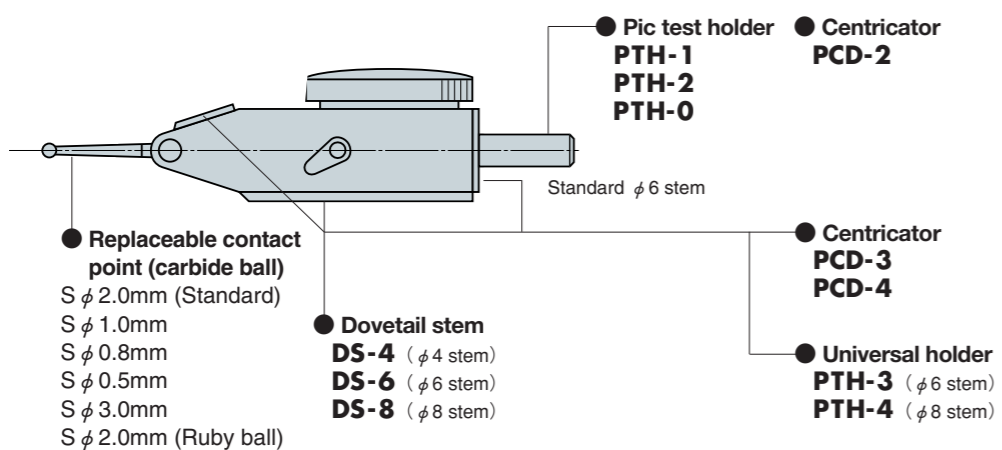
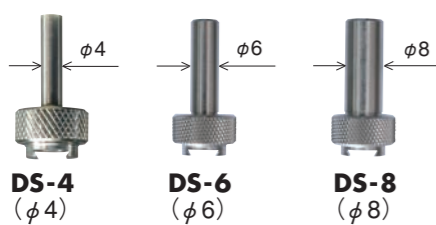

Replaceable Contact Points (M1.7 × 0.35)

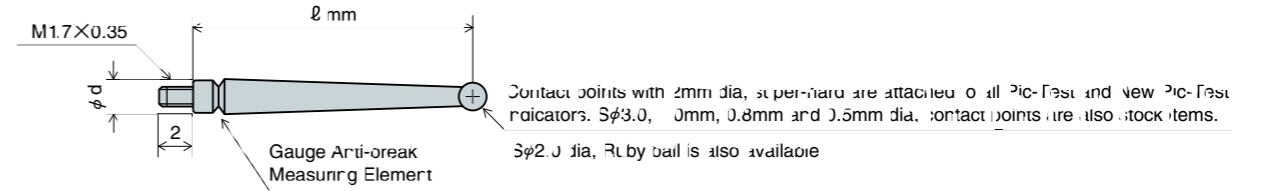

For Pic Test (Change lever type)

Part No.	ℓ (mm)	φ ball (mm)	φ d (mm)	Applicable Indicator
XP1A-3	18.2	3	2.5	PC-1A PC-1AE PC-3
XP1A-2	18.2	2	2.5	PC-1A PC-1AE PC-3
XP1A-2R (ruby ball)	18.2	2	2.5	PC-1A PC-1AE PC-3
XP1A-1	18.2	1	2.5	PC-1A PC-1AE PC-3
XP1A-08	18.2	0.8	2.5	PC-1A PC-1AE PC-3
XP1A-05	18.2	0.5	2.5	PC-1A PC-1AE PC-3
XP1B-3	19.24	3	2.5	PC-1B PC-1BE PC-1BW
XP1B-2	19.24	2	2.5	PC-1B PC-1BE PC-1BW
XP1B-2R (ruby ball)	19.24	2	2.5	PC-1B PC-1BE PC-1BW
XP1B-1	19.24	1	2.5	PC-1B PC-1BE PC-1BW
XP1B-08	19.24	0.8	2.5	PC-1B PC-1BE PC-1BW
XP1B-05	19.24	0.5	2.5	PC-1B PC-1BE PC-1BW
XP1L-3	39.72	3	3.0	PC-1L PC-1LE PC-3L
XP1L-2	39.72	2	3.0	PC-1L PC-1LE PC-3L
XP1L-2R (ruby ball)	39.72	2	3.0	PC-1L PC-1LE PC-3L
XP1L-1	39.72	1	3.0	PC-1L PC-1LE PC-3L
XP1L-08	39.72	0.8	3.0	PC-1L PC-1LE PC-3L
XP1L-05	39.72	0.5	3.0	PC-1L PC-1LE PC-3L
XP2-3	8.80	3	2.2	PC-2 PC-4
XP2-2	8.80	2	2.2	PC-2 PC-4
XP2-2R (ruby ball)	8.80	2	2.2	PC-2 PC-4
XP2-1	8.80	1	2.2	PC-2 PC-4
XP2-08	8.80	0.8	2.2	PC-2 PC-4
XP2-05	8.80	0.5	2.2	PC-2 PC-4

For New Pic Test (without Change lever type)

Part No.	ℓ (mm)	φ ball (mm)	φ d (mm)	Applicable Indicator
XN1A-3	17.74	3	2.5	PCN-1A PCN-0 PCN-1AE PCN-1AD PCN-5 PCN-7A
XN1A-2	17.74	2	2.5	PCN-1A PCN-0 PCN-1AE PCN-1AD PCN-5 PCN-7A
XN1A-2R (ruby ball)	17.74	2	2.5	PCN-1A PCN-0 PCN-1AE PCN-1AD PCN-5 PCN-7A PCN-1AU PCN-5U
XN1A-1	17.74	1	2.5	PCN-1A PCN-0 PCN-1AE PCN-1AD PCN-5 PCN-7A
XN1A-08	17.74	0.8	2.5	PCN-1A PCN-0 PCN-1AE PCN-1AD PCN-5 PCN-7A
XN1A-05	17.74	0.5	2.5	PCN-1A PCN-0 PCN-1AE PCN-1AD PCN-5 PCN-7A
XN1B-3	18.63	3	2.5	PCN-1B PCN-1BE PCN-1BZ (A)-(B)
XN1B-2	18.63	2	2.5	PCN-1B PCN-1BE PCN-1BZ (A)-(B)
XN1B-2R (ruby ball)	18.63	2	2.5	PCN-1B PCN-1BE PCN-1BU PCN-1BZ (A)-(B)
XN1B-1	18.63	1	2.5	PCN-1B PCN-1BE PCN-1BZ (A)-(B)
XN1B-08	18.63	0.8	2.5	PCN-1B PCN-1BE PCN-1BZ (A)-(B)
XN1B-05	18.63	0.5	2.5	PCN-1B PCN-1BE PCN-1BZ (A)-(B)
XN1L-3	39.00	3	2.5	PCN-1L PCN-1LE PCN-1LD PCN-1LZ (A)-(B)
XN1L-2	39.00	2	2.5	PCN-1L PCN-1LE PCN-1LD PCN-1LZ (A)-(B)
XN1L-2R (ruby ball)	39.00	2	2.5	PCN-1L PCN-1LE PCN-1LD PCN-1LU PCN-1LZ (A)-(B)
XN1L-1	39.00	1	2.5	PCN-1L PCN-1LE PCN-1LD PCN-1LZ (A)-(B)
XN1L-08	39.00	0.8	2.5	PCN-1L PCN-1LE PCN-1LD PCN-1LZ (A)-(B)
XN1L-05	39.00	0.5	2.5	PCN-1L PCN-1LE PCN-1LD PCN-1LZ (A)-(B)
XN2-3	14.33	3	2.2	PCN-2 PCN-2E PCN-6 PCN-2Z (A)-(B)
XN2-2	14.33	2	2.2	PCN-2 PCN-2E PCN-6 PCN-2Z (A)-(B)
XN2-2R (ruby ball)	14.33	2	2.2	PCN-2 PCN-2E PCN-6 PCN-2U PCN-6U PCN-2Z (A)-(B)
XN2-1	14.33	1	2.2	PCN-2 PCN-2E PCN-6 PCN-2Z (A)-(B)
XN2-08	14.33	0.8	2.2	PCN-2 PCN-2E PCN-6 PCN-2Z (A)-(B)
XN2-05	14.33	0.5	2.2	PCN-2 PCN-2E PCN-6 PCN-2Z (A)-(B)
XN2B-3	13.00	3	2.2	PCN-2B PCN-2BD PCN-7C PCN-SD
XN2B-2	13.00	2	2.2	PCN-2B PCN-2BD PCN-7C PCN-SD
XN2B-2R (ruby ball)	13.00	2	2.2	PCN-2B PCN-2BD PCN-7C PCN-SD PCN-2BU
XN2B-1	13.00	1	2.2	PCN-2B PCN-2BD PCN-7C PCN-SD
XN2B-08	13.00	0.8	2.2	PCN-2B PCN-2BD PCN-7C PCN-SD
XN2B-05	13.00	0.5	2.2	PCN-2B PCN-2BD PCN-7C PCN-SD
XNS-3	8.13	3	2.2	PCN-S
XNS-2	8.13	2	2.2	PCN-S
XNS-2R (ruby ball)	8.13	2	2.2	PCN-S PCN-SU
XNS-1	8.13	1	2.2	PCN-S
XNS-08	8.13	0.8	2.2	PCN-S
XNS-05	8.13	0.5	2.2	PCN-S

Dimensions of Lever Type Dial Indicators

Dimensions of Lever Type Dial Indicators

Contact Points Length and Types

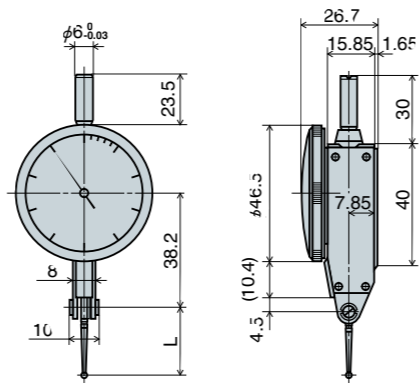
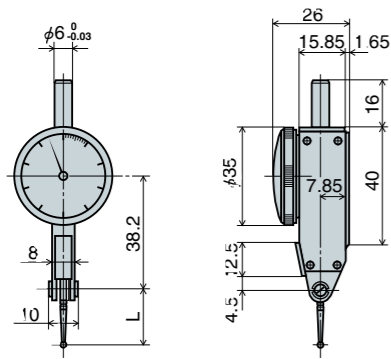

Model	L (mm)
PCN-1A . PCN-1AE . PCN-1AU . PCN-7A	21.3
PCN-1B . PCN-1BE . PCN-1BU . PCN-1BZ(A)(B)	22.2
PCN-1L . PCN-1LE . PCN-1LU . PCN-1LZ(A)(B)	42.8
PCN-2 . PCN-2E . PCN-2U . PCN-2Z(A)(B)	17.94
PCN-2B . PCN-2BU	16.6
PCN-S	11.7
PCN-7C	16.6

Model	L (mm)
PCN-1AD	21.3
PCN-2BD . PCN-SD	16.6
PCN-1LD	42.8

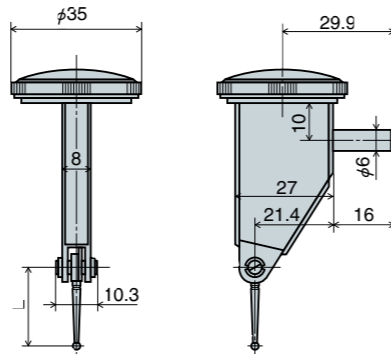
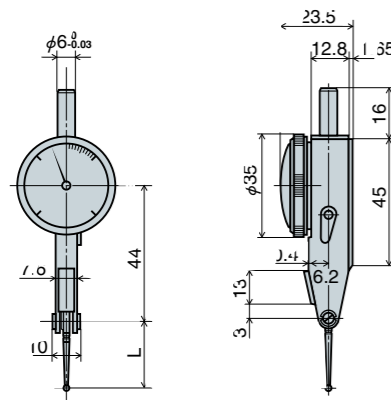

Model	L (mm)
PC-1A . PC-1AE	21.4
PC-1B . PC-1BE	22.4
PC-1L . PC-1LE	43.0
PC-2	12.0

Model	L (mm)
PCN-5 . PCN-5U	21.3
PCN-6 . PCN-6U	17.94

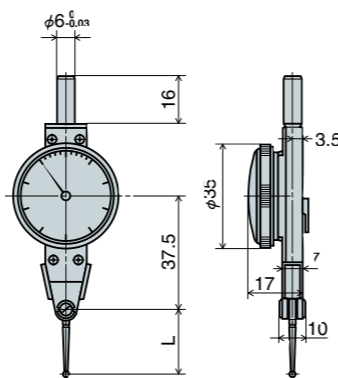
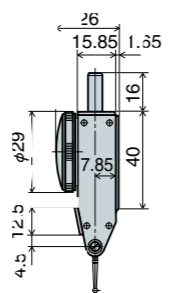
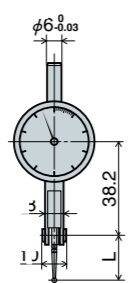
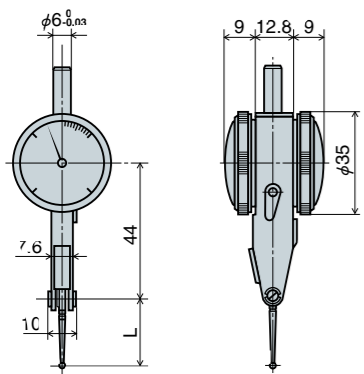

Model	L (mm)
PC-1BW	22.4

Model	L (mm)
PCN-0	21.3

Model	L (mm)
PC-3	21.4
PC-4	12.0
PC-3L	43.0

Applied Examples

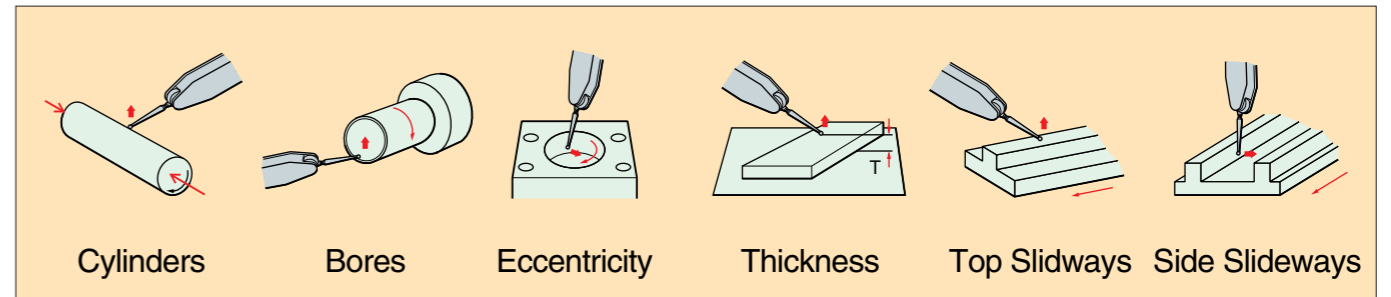

Precautions for Handling

- Dial gauges shall be used by being fixed to a rigid retainer to prevent the influence of flexure or the like. In measurement, the measuring direction shall be made perpendicular to the center line of the measuring probe.

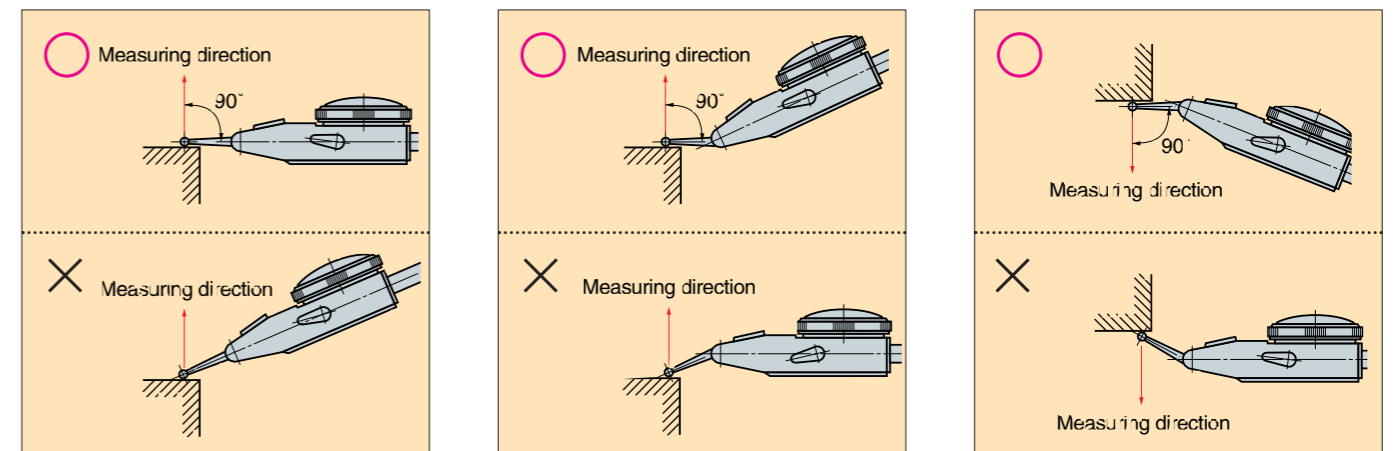

- In case they are not perpendicular, a correction by the following formula is necessary: Due to various measuring direction, the contact point sometimes can not be angled perpendicular to the measuring device.

Examples the diagrams below, where the measuring probe is set at a non-perpendicular angles and the distance between the pivot of the contact point and the measuring device is signified by the letter H:

Displacement = quantity of pointer movement x COS θ

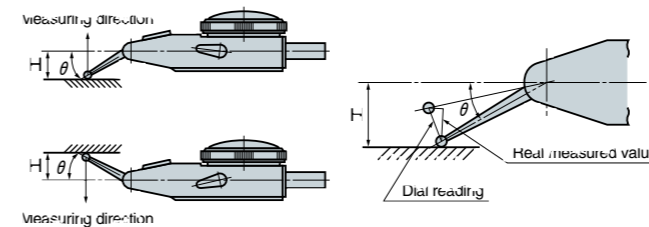

Example:
Using a PC-1A indicator, suppose the degree of angle is 30° and the Pic Test reading is 0.05mm. The factor for the PC-1A indicator from the graph is 0.87.
 $0.05\text{mm} \times 0.87 = 0.0435 = 0.043\text{mm}$

- When modification is not necessary: If the measuring tolerance is 10% and the graph factor is above 0.9, modification by calculation is unnecessary.

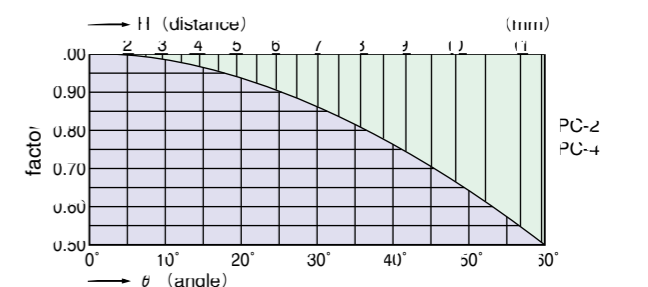
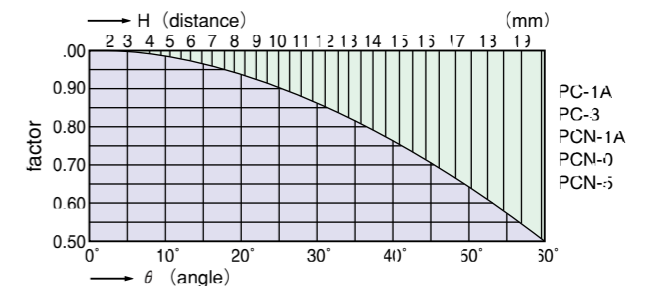

Special Type Pic Test Indicators

Without stem type V series

Our standard Pic Test Indicators have $\phi 6\text{mm}$ fixed stem.
If you do not need it, we can supply Pic Test Indicators without stem or with Dovetail Stem. ($\phi 4\text{mm}$, $\phi 6\text{mm}$ or $\phi 8\text{mm}$)

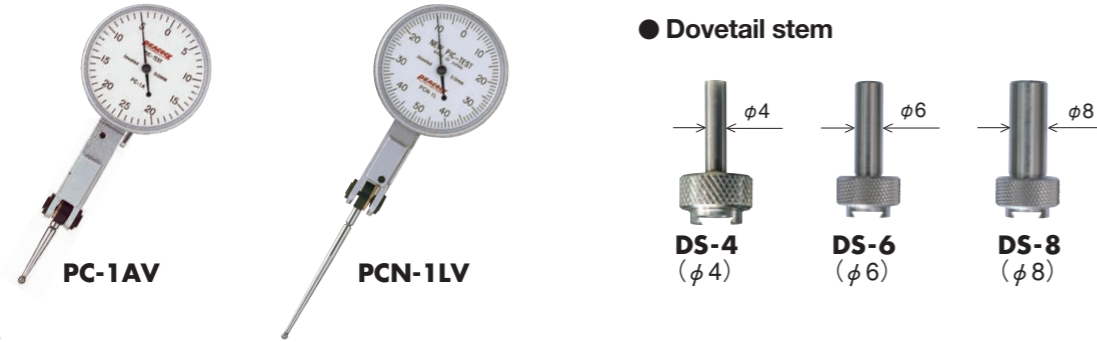

Specifications

Model	Graduation (mm)	Range (mm)	Reading	Accuracy (μm)			Measuring force less than(N)
				Wide-range forward accuracy	Adjacent error	Backward error	
PC-1AV	0.01	0.5	0 - 25 - 0	5	5	3	0.4
PC-1BV	0.01	0.8	0 - 40 - 0	8	5	3	0.4
PC-1LV	0.01	1.0	0 - 50 - 0	10	5	4	0.4
PC-2V	0.002	0.28	0 - 140 - 0	3	2	2	0.4
PCN-1AV	0.01	0.5	0 - 25 - 0	5	5	3	0.3
PCN-1BV	0.01	0.8	0 - 40 - 0	8	5	3	0.3
PCN-1LV	0.01	1.0	0 - 50 - 0	10	5	4	0.3
PCN-2V	0.002	0.28	0 - 140 - 0	3	2	2	0.3
PCN-2BV	0.002	0.2	0 - 100 - 0	3	2	2	0.3
PCN-SV	0.001	0.14	0 - 70 - 0	3	2	2	0.3

*We also can supply other Pic Test Indicators without $\phi 6\text{mm}$ fixed stem.

Right Angle Contact Point for PIC TEST (PAT.No.3065810)

Unique Contact Point not existing before!

Contact Point Part No. XPILX-2

A Contact Point end bent at a right has made it possible to make a measurement of an object that used to be impossible to measure!

Set the Contact Point so that it is horizontal and perpendicular to work.

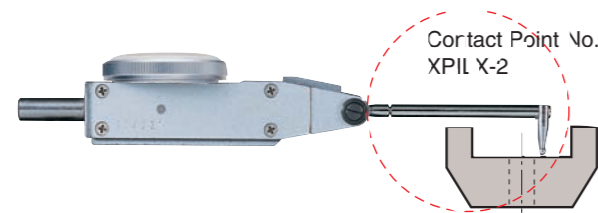

The Contact Point enable a measurement of a recessed portion located at the back of a project portion that would not be possible by the use of an existing Contact Point.

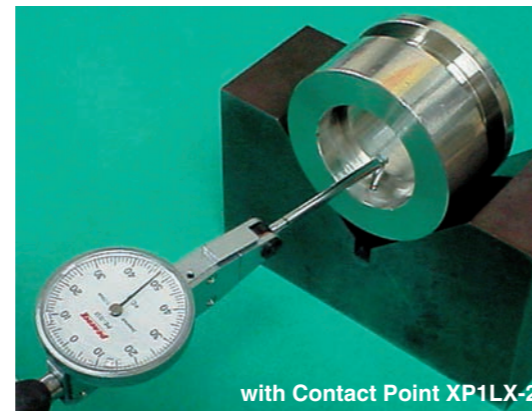
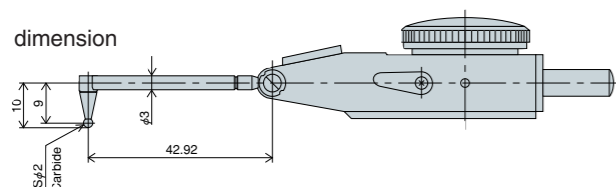

Also makes it possible to measure the parallelism and run-out of grooves on different levels.

Right Angle Contact Point for PIC TEST (PAT.No.3065810)

SECTION

3



3

Cylinder Gauges

- Standard Cylinder Gauges
CC Series
CG Series
- Special Cylinder Gauges
S Series
- "R" Series

Standard Cylinder Gauges

JIS B 7515

CC series

Peacock offers a complete line of Dial Bore Gauges with interchangeable anvils and necessary accessories to perform close tolerance measurements of holes, taper and roundness.

- Dial gauge mounting knob is very simple and sure avoiding demerit of collet-system.
- The contact point is tungsten carbide ball.
- The standard ball tipped at the replacement rod is made of steel. The sintered hard-alloy ball is also available to tip.
- Wide range accuracy.....5 μm or less
Adjacent error.....2 μm or less
Repeated accuracy.....2 μm or less
- Effective measuring range is 0.5 mm (CC-02 CC-01)
- Effective measuring range is 1.2 mm (CC-1 to CC-6)

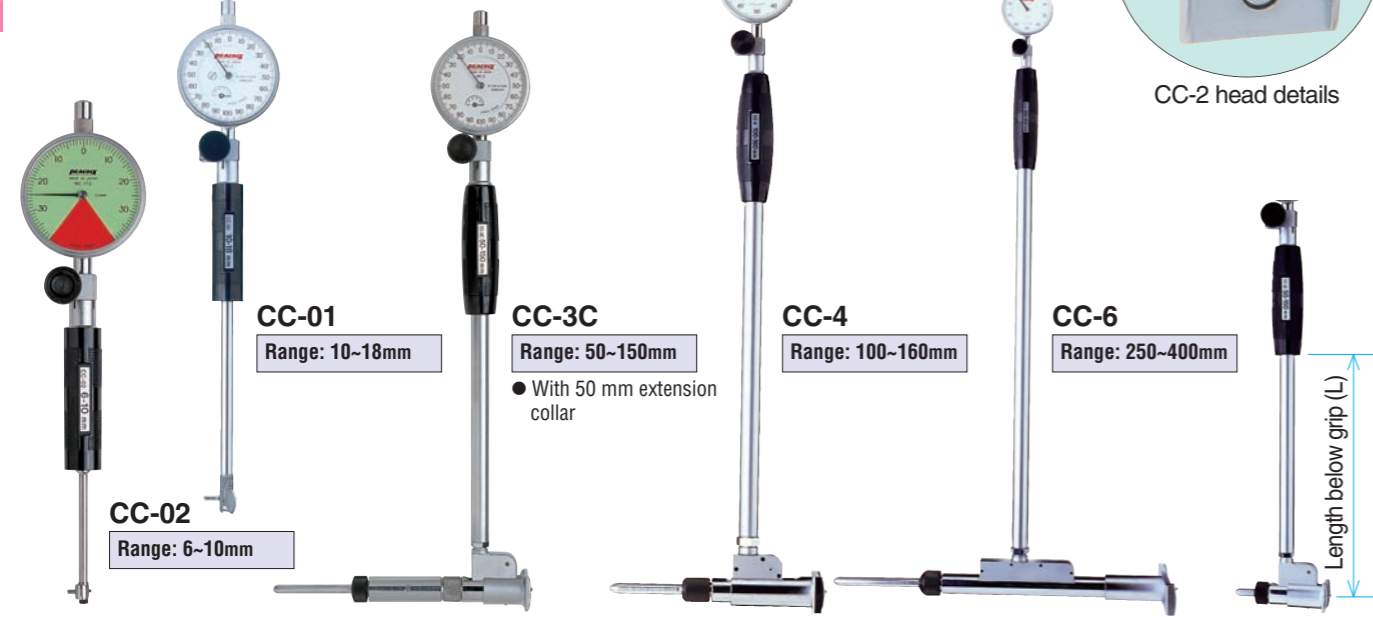

Specifications

Model	Range (mm)	Length below grip (mm)	Number of Feelers (mm)	Thickness of Washers (mm)
CC-02	6 ~ 10	50	Intervals 0.5 mm x 9	—
CC-01	10 ~ 18	100	Intervals 1 mm x 9	0.5 mm
CC-1	18 ~ 35	150	Intervals 2 mm x 9	0.5, 1 mm each
CC-2	35 ~ 60	150	Intervals 5 mm x 6	1,2,3 mm each
CC-3	50 ~ 100	150	Intervals 5 mm x 11	1,2,3 mm each
CC-3C	50 ~ 150	150	Intervals 5 mm x 11	1,2,3 mm each
CC-4	100 ~ 160	250	Intervals 10 mm x 7	1,2,3,4 mm each
CC-5	160 ~ 250	250	Intervals 10 mm x 10	1,2,3,4 mm each
CC-6	250 ~ 400	400	Intervals 10 mm x 16	1,2,3,4 mm each

※Dial gauge is not furnished and supplied only on request. Suitable dial gauges are 17Z, 57B (0.01mm) and 15Z, 5F (0.001mm).

● List of special length below grip (available on request)

	L=50 (mm)	L=100 (mm)	L=200 (mm)	L=300 (mm)	L=400 (mm)	L=500 (mm)	L=600 (mm)	L=700 (mm)	L=800 (mm)	L=900 (mm)	L=1000 (mm)	L=1500 (mm)	L=2000 (mm)
CC-01	●	standard	●	●	—	—	—	—	—	—	—	—	—
CC-1	CC-1S	●	●	●	●	●	—	—	—	—	—	—	—
CC-2	CC-2S	●	●	●	●	●	●	●	●	●	●	●	●
CC-3	CC-3S	●	●	●	●	●	●	●	●	●	●	●	●
CC-3C	CC-3CS	●	●	●	●	●	●	●	●	●	●	●	●
CC-4	●	●	●	●	●	●	●	●	●	●	●	●	●
CC-5	●	●	●	●	●	●	●	●	●	●	●	●	●
CC-6	●	●	●	●	standard	●	●	●	●	●	●	●	●

● More than L=600mm for CC-2 can not measure from 35 to 44mm and can measure from 45 to 60mm ID.



CC-2 complete set

Short Size Cylinder Gauges

S series

This is a compact cylinder gauge with a length below grip of 50 mm.

It is used when a standard item is too long to measure the object or a shorter length of below grip is required for conveniently.

Specifications are same as standard model.



Outer Dimension

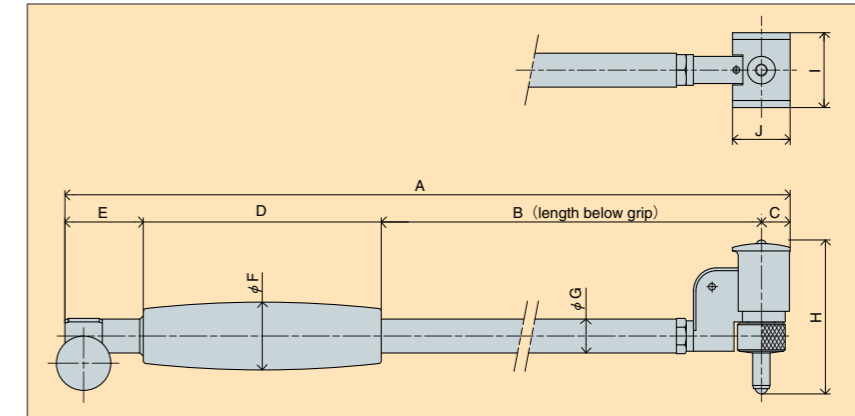

Dimension

Model	A	B	C	D	E	F	G	H	I	J
CC-1	249	150	5.75	70	23	20	10	18~35	13	11.5
CC-2	251.5	150	8.5	70	23	20	10	35~60	22	17
CC-3	253	150	9	70	23	20	10	50~100	30	18
CC-3C	253	150	9	70	23	20	10	50~150	30	18
CC-4	370	250	12	85	23	25	13	100~160	50	24
CC-5	391.5	251.5	14	100	26	25	16	160~250	70	28
CC-6	540	400	14	100	26	25	16	250~400	100	28
CC-1S	150	50	5.75	70	23	20	10	18~35	13	11.5
CC-2S	151.5	50	8.5	70	23	20	10	35~60	22	17
CC-3S	152	50	9	70	23	20	10	50~100	30	18
CC-3CS	152	50	9	70	23	20	10	50~150	30	18



Cylinder Gauges (Blind Hole Type)

CG series

If using a CC type cylinder gauge for blind hole bore diameter, its guide plate interrupt the measurement at a point deeper than "T", as shown in the figure below.

In such case, the CG type with modified guide plate is suitable for measurement of the diameter to the point as deep as "t".

- Wide range accuracy...5 μm or less
- Adjacent error...2 μm or less
- Repeated accuracy...2 μm or less
- Effective measuring range is 0.5 mm (CG-01)
- Effective measuring range is 1.2 mm (CG-1 to CG-6)

Applied Example

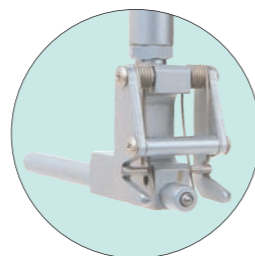
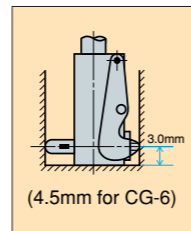
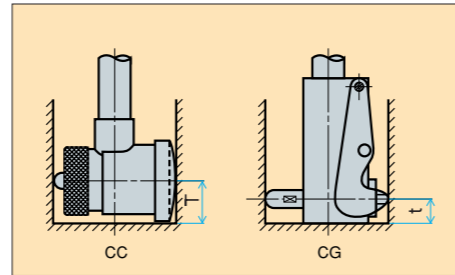

CG-2 head details

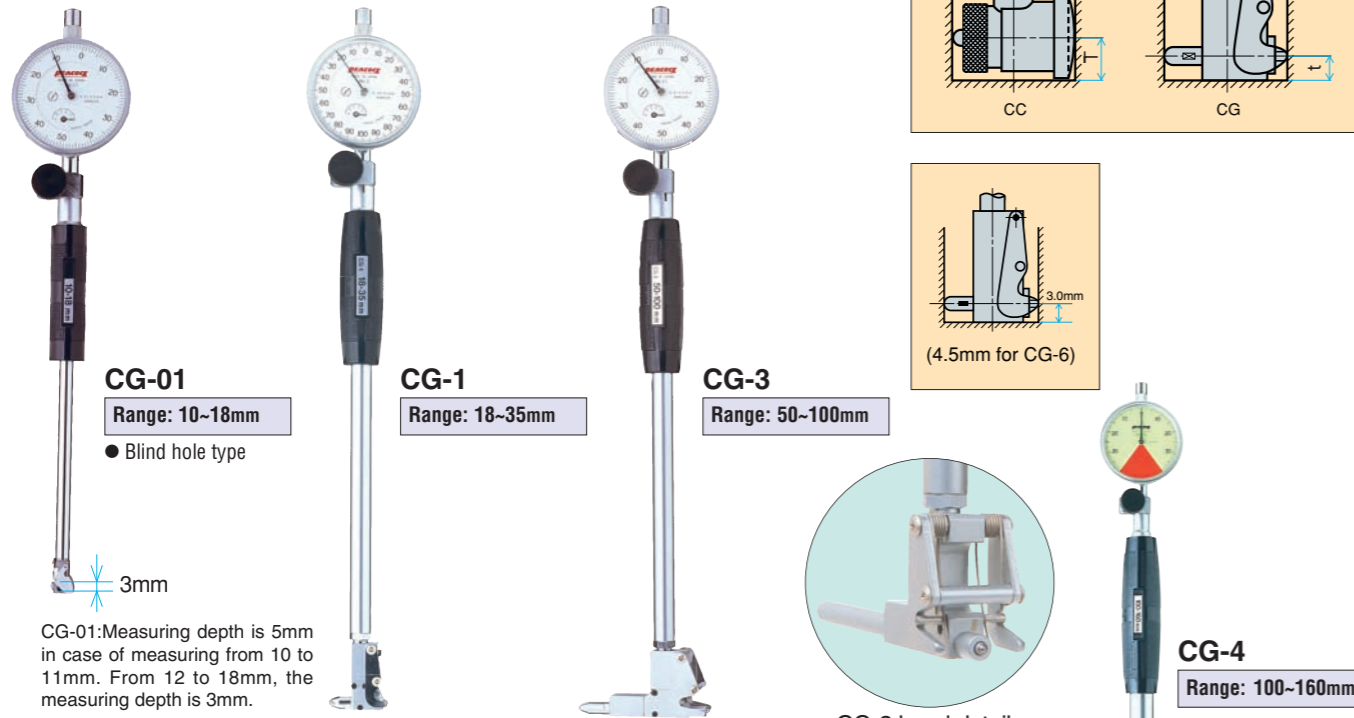

Specifications

Model	Range (mm)	Length below grip (mm)	Number of Feelers (mm)	Thickness of Washers (mm)
CG-01	10 ~ 18	100	Intervals 1 mm x 9	0.5 mm each
CG-1	18 ~ 35	150	Intervals 2 mm x 9	0.5, 1 mm each
CG-2	35 ~ 60	150	Intervals 5 mm x 6	0.5, 1, 2, 3 mm each
CG-3	50 ~ 100	150	Intervals 5 mm x 11	0.5, 1, 2, 3 mm each
CG-3C	50 ~ 150	150	Intervals 5 mm x 11	0.5, 1, 2, 3 mm each
CG-4	100 ~ 160	250	Intervals 10 mm x 7	1, 2, 3, 4 mm each
CG-5	160 ~ 250	250	Intervals 10 mm x 10	1, 2, 3, 4 mm each
CG-6	250 ~ 400	400	Intervals 10 mm x 16	1, 2, 3, 4 mm each

※ Dial gauge is not furnished and supplied only on request. Suitable dial gauges are 17Z, 57B (0.01mm) and 15Z, 5F (0.001mm).

※ CG-3C includes 50 mm extension collar.

※ In general, it is the range from the origin, that is the position where the plunger is pushed in by 0.1 mm, to the position where the plunger is pushed in further by 1.2 mm.

● List of special length below grip (available on request)

	L=50 (mm)	L=100 (mm)	L=150 (mm)	L=200 (mm)	L=250 (mm)	L=300 (mm)	L=400 (mm)	L=500 (mm)	L=600 (mm)	L=700 (mm)	L=800 (mm)	L=900 (mm)	L=1000 (mm)
CG-01	●	standard	●	●	●	●							
CG-1	●	●	standard	●	●	●	●	●					
CG-2	●	●	standard	●	●	●	●	●	●	●	●	●	●
CG-3	●	●	standard	●	●	●	●	●	●	●	●	●	●
CG-3C	●	●	standard	●	●	●	●	●	●	●	●	●	●
CG-4	●	●	●	●	standard	●	●	●	●	●	●	●	●
CG-5	●	●	●	●	standard	●	●	●	●	●	●	●	●
CG-6	●	●	●	●	●	●	standard	●	●	●	●	●	●

Dimensions for Feeler and Washer for Cylinder Gauges

CC-1 Feeler

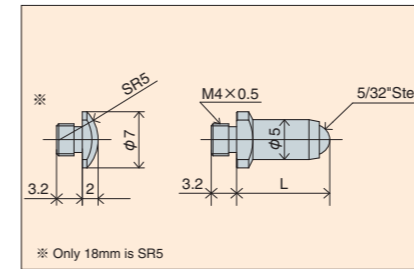

※ Only 18mm is SR5

Model	Size (mm)	L (mm)
CC-1 Feeler	18	2
	20	4
	22	6
	24	8
	26	10
	28	12
	30	14
	34	18

CC-2 Feeler

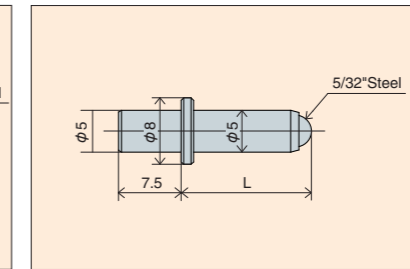

Model	Size (mm)	L (mm)
CC-2 Feeler	35	5
	40	10
	45	15
	50	20
	55	25
	60	30

CC-3·3C Feeler

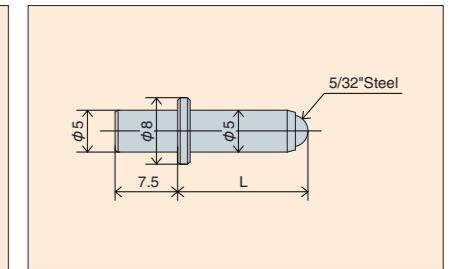

Model	Size (mm)	L (mm)
CC-3·3C Feeler	50	5
	55	10
	60	15
	65	20
	70	25
	75	30
	80	35
	85	40
	90	45
	100	55

CC-4 Feeler

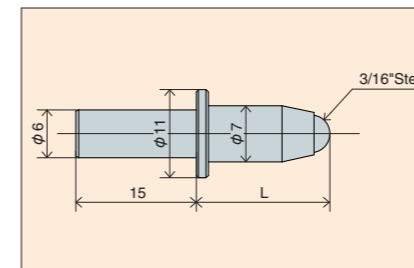

Model	Size (mm)	L (mm)
CC-4 Feeler	100	10
	110	20
	120	30
	130	40
	140	50
	150	60
	160	70

CC-5 Feeler

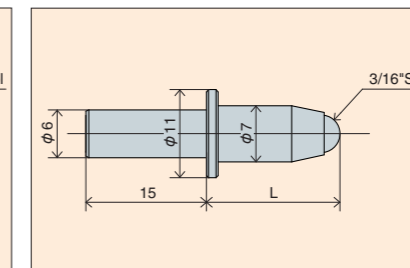

Model	Size (mm)	L (mm)
CC-5 Feeler	160	10
	170	20
	180	30
	190	40
	200	50
	210	60
	220	70
	230	80
	240	90
	250	100

CC-6 Feeler

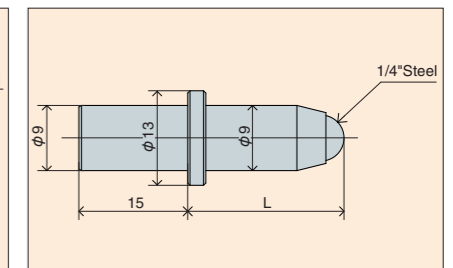

Model	Size (mm)	L (mm)
CC-6 Feeler	250	10
	260	20
	270	30
	280	40
	290	50
	300	60
	310	70
	320	80
	330	90
	340	100
	350	110
	360	120
	370	130
	380	140

CC-1~6 Washer

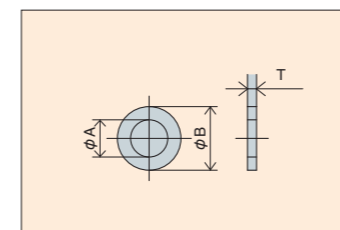

Model	T (mm)	A (mm)	B (mm)
CC-1	0.5, 1	4.1	7
CC-2	1, 2, 3	5.1	8
CC-3·3C	1, 2, 3	5.1	8
CC-4	1, 2, 3, 4	6.1	10
CC-5	1, 2, 3, 4	6.1	10
CC-6	1, 2, 3, 4	9.1	13

Cylinder Gauges

CC·CG-R series

Do you have any trouble when measuring internal diameter?
If so, we offer more radii of Contact Point & Feeler for Cylinder Gauges "R" Series.

- Wide range accuracy...5 μm or less
- Adjacent error...2 μm or less
- Repeated accuracy...2 μm or less

CC-1R



CC-3R



Specifications for CC-"R" series

Model	Range	Length below grip	Number of feelers	Thickness of washers	Extension collar
CC-01R	10~ 18mm	100mm	Intervals 0.5mm× 9	0.5mm	—
CC-1R	18~ 35mm	150mm	Intervals 2mm× 9	0.5, 1mm each	—
CC-2R	35~ 60mm	150mm	Intervals 5mm× 6	1, 2, 3mm each	—
CC-3R	50~100mm	150mm	Intervals 5mm× 11	1, 2, 3mm each	—
CC-3CR	50~150mm	150mm	Intervals 5mm× 11	1, 2, 3mm each	50mm

Specifications for CG-"R" series

Model	Range	Length below grip	Number of feelers	Thickness of washers	Extension collar
CG-01R	10~ 18mm	100mm	Intervals 0.5mm× 9	0.5mm	—
CG-1R	18~ 35mm	150mm	Intervals 2mm× 9	0.5, 1mm each	—
CG-2R	35~ 60mm	150mm	Intervals 5mm× 6	0.5, 1, 2, 3mm each	—
CG-3R	50~100mm	150mm	Intervals 5mm× 11	0.5, 1, 2, 3mm each	—
CG-3CR	50~150mm	150mm	Intervals 5mm× 11	0.5, 1, 2, 3mm each	50mm

Note: CG-01, in case 10~11mm measurement, the measuring depth is 5mm but 11~18mm is 3mm measuring depth.

Contact Point Hv700±50 (Tip heat treatment and hardened)

CC-01R
CG-01R

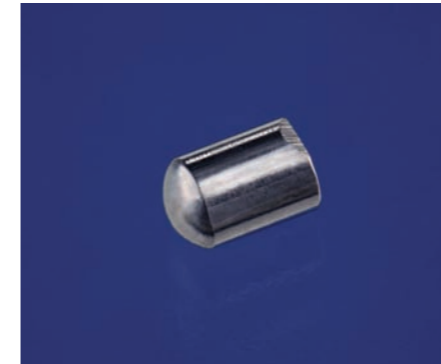

CC-1R · CG-1R · CG-2R
CG-3R · CG-3CR



CC-2R · CC-3R
CC-3CR



Feeler Hv700±50 (Tip heat treatment and hardened)

CC-01R
CG-01R



CC-1R



CC-2R · CC-3R
CC-3CR



Feeler Hv700±50 (Tip heat treatment and hardened)

CG-1R



CG-2R · CG-3R
CG-3CR



"R" Series Cylinder Gauges can be made Special Production as following:

- 1 Long Size of Length below grip Cylinder Gauge
- 2 Short Size of Length below grip Cylinder Gauge
- 3 Short Size of the overall length Cylinder Gauge
- 4 L-shaped Cylinder Gauge

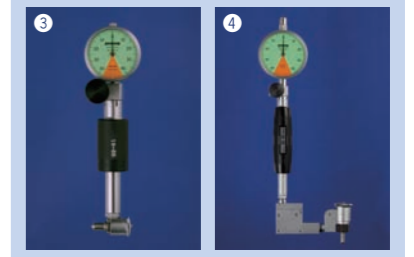

Dimensions for Feeler and Washer for R series Cylinder Gauges:

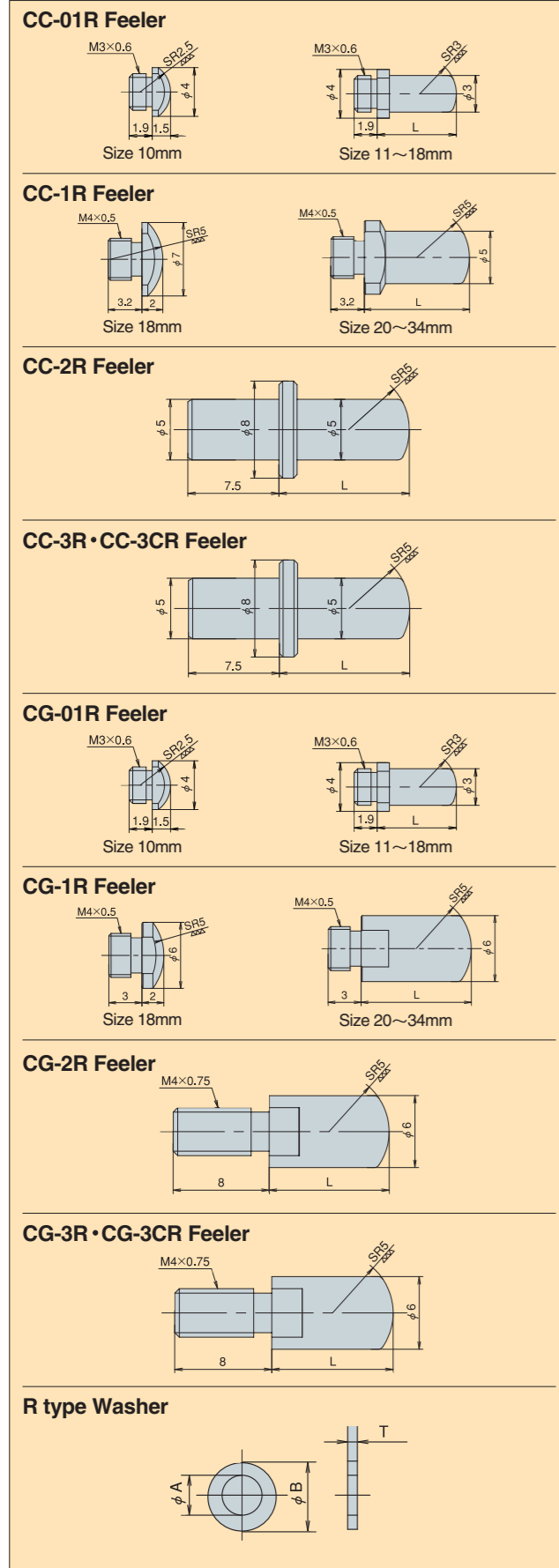

Size (mm)	L (mm)	Size (mm)	L (mm)
10	1.5	15	6.5
11	2.5	16	7.5
12	3.5	17	8.5
13	4.5	18	9.5
14	5.5		

Size (mm)	L (mm)	Size (mm)	L (mm)
18	2	28	12
20	4	30	14
22	6	32	16
24	8	34	18
26	10		

Size (mm)	L (mm)	Size (mm)	L (mm)
35	5	50	20
40	10	55	25
45	15	60	30

Size (mm)	L (mm)	Size (mm)	L (mm)
50	5	80	35
55	10	85	40
60	15	90	45
65	20	95	50
70	25	100	55
75	30		

Size (mm)	L (mm)	Size (mm)	L (mm)
10	1.5	15	6.5
11	2.5	16	7.5
12	3.5	17	8.5
13	4.5	18	9.5
14	5.5		

Size (mm)	L (mm)	Size (mm)	L (mm)
18	2	28	12
20	4	30	14
22	6	32	16
24	8	34	18
26	10		

Size (mm)	L (mm)	Size (mm)	L (mm)
35	5	50	20
40	10	55	25
45	15	60	30

Size (mm)	L (mm)	Size (mm)	L (mm)
50	5	80	35
55	10	85	40
60	15	90	45
65	20	95	50
70	25	100	55
75	30		

Model	T	A	B
CC01-R	0.5	3.1	4.5
CC-1R	0.5 · 1	4.1	7
CC-2R	1 · 2 · 3	5.1	8
CC-3R · CC-3CR	1 · 2 · 3	5.1	8
CG01-R	0.5	3.1	4.5
CG-1R	0.5 · 1	4.1	5
CG-2R	0.5 · 1 · 2 · 3	4.1	6
CG-3R · CG-3CR	0.5 · 1 · 2 · 3	4.1	6





Inch Scale Dial Indicators

- Dial Gages
- Dial Gages (Metric)
- Pic Test Indicators
- Dial Bore Gage Sets
- Dial Thickness Gage

Dial Gages

0.001"

- Easy-reading distinct graduations.
- Inch models have standard black needles and white dial faces or new high visibility orange needles and black faces. Metric models have yellow dial faces. (see page 72)
- Hard, satin-chrome finish.
- Superior quality of spindle rack, pinions and gear trains ensure longevity.
- Meets or exceeds applicable US federal specifications.
- Conforms to AGD specifications.

Dimensions

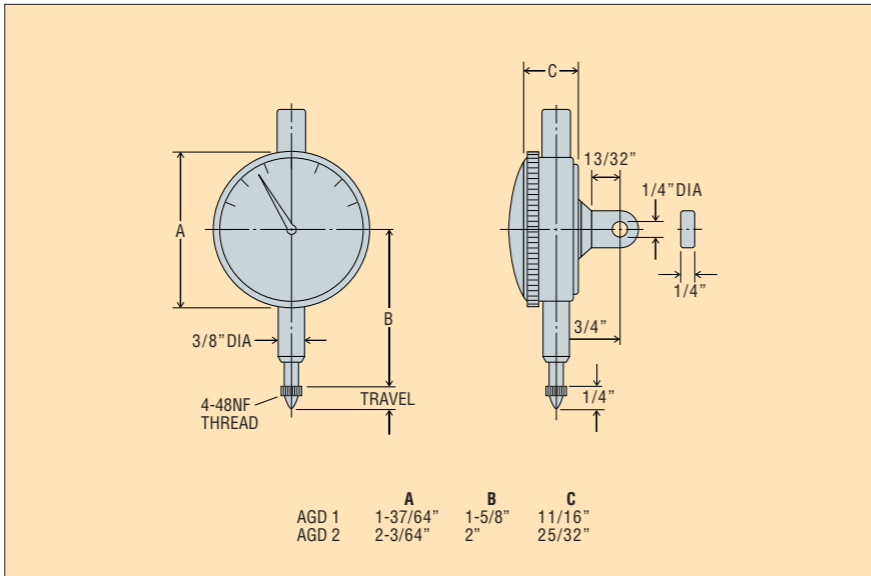

0.001"



0.0001"



Specifications

White face Model No.	Black face Model No.	Measuring range	Graduation	Reading	Wide range forward accuracy	Retrace error	Measuring force (less than)	Back Config.	AGD
1200		.20"	.001"	±0-50-100	.0008"	.0003"	1.4N	Lug	1
1330	1330B	1.0"	.001"	±0-50-100	.002"	.0004"	2.0N	Lug	2
1310	1310B	.50"	.001"	±0-50-100	.001"	.0003"	1.8N	Lug	2
1364	1364B	2.0"	.001"	±0-50-100	.004"	.0004"	2.5N	Lug	2
1440	1440B	.05"	.0001"	±0-5-10	.0003"	.0002"	1.5N	Lug	2
1460	1460B	.05"	.0001"	0-5-0	.0003"	.0002"	1.5N	Flat	2

Inch Scale Dial Indicators

Inch Scale Dial Indicators

4 Metric Graduations 0.01mm

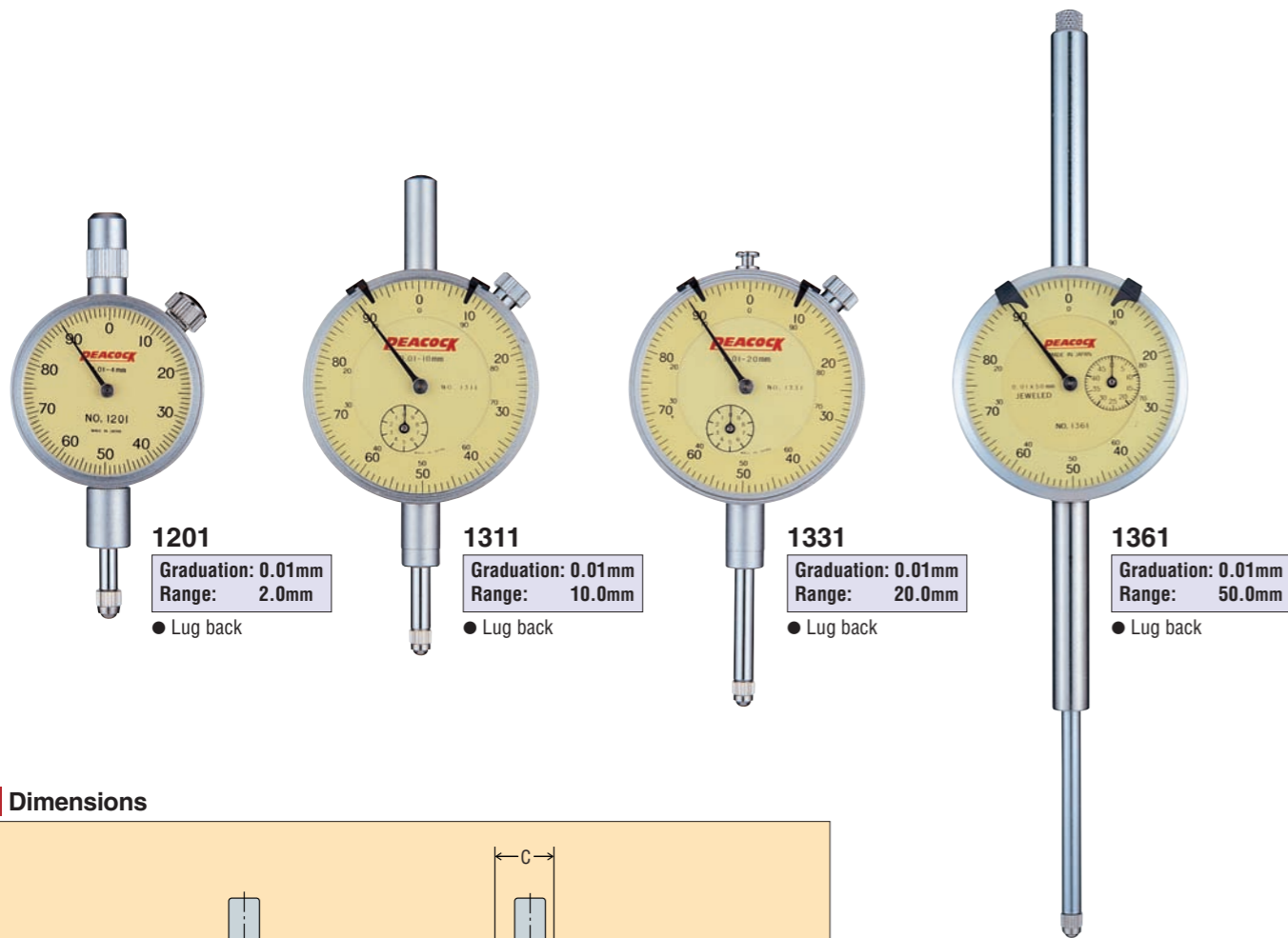

Dimensions

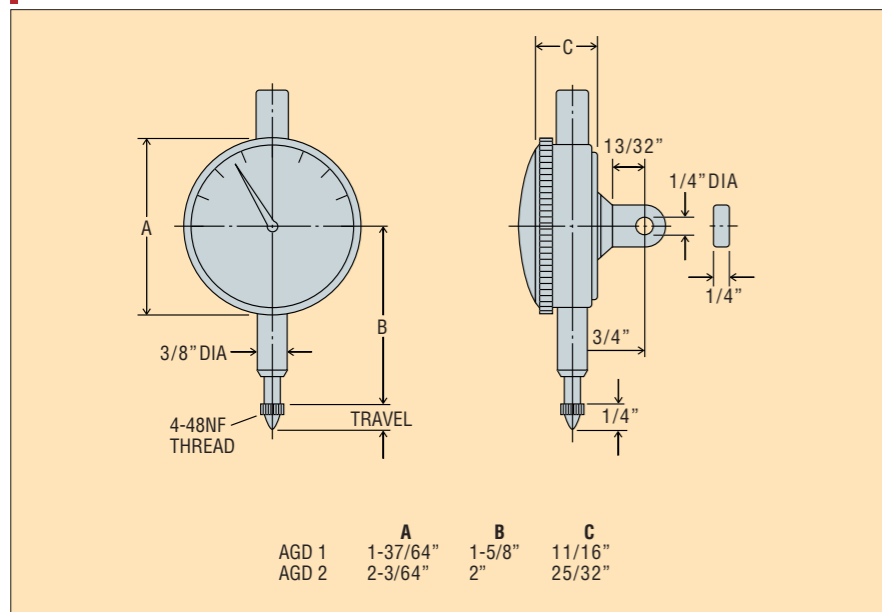

Specifications

Model No.	Measuring range	Graduation	Reading	Wide range forward accuracy	Retrace error	Measuring force (less than)	Back Config.	AGD
1201	4.0mm	0.01mm	±0-50-100	12 μm	3 μm	1.4N	Lug	1
1311	10.0mm	0.01mm	±0-50-100	15 μm	3 μm	1.4N	Lug	2
1331	20.0mm	0.01mm	±0-50-100	25 μm	4 μm	2.2N	Lug	2
1361	50.0mm	0.01mm	±0-50-100	50 μm	5 μm	2.5N	Lug	2

Pic Test Indicators

- Auto-reversing.
- Comes complete with .038", .078", .125" dia hardchromed contact points, Clamping bars, wrench and three stems: 3/8", 1/4" and 5/32".
- 180° swing on point and shaft.
- Fully jeweled movements.
- White face models have black needles, numbers and graduations. Black face models have bright, fluorescent orange needles with white numbers and graduations.
- Dial diameter is 1-3/8".
- Universal positioning capability.
- Dovetails on top, back & front.
- Excellent rigid
- Non-magnetic

Horizontal Type

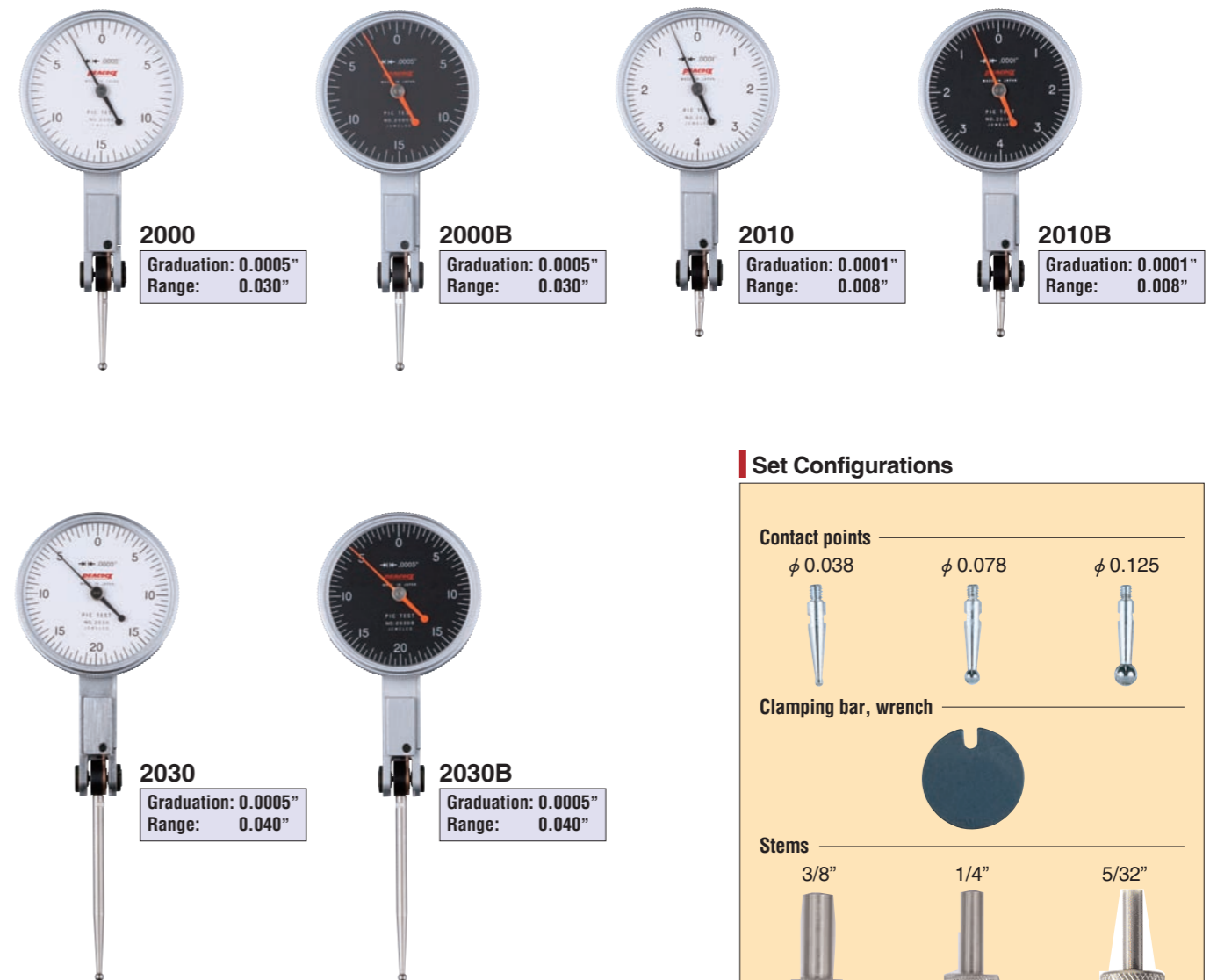

Set Configurations

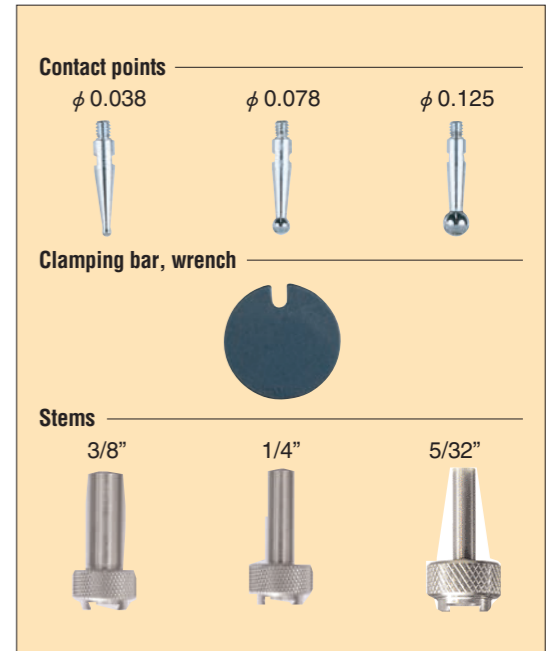

Specifications

White face Model No.	Black face Model No.	Measuring range	Graduation	Reading	Wide range forward accuracy	Backward error	Measuring force (less than)	Contact point length
2000	2000B	.030"	.0005"	0-15-0	.0005"	.0003"	0.3N	.750"
2010	2010B	.008"	.0001"	0-4-0	.0003"	.0002"	0.3N	.375"
2030	2030B	.040"	.0005"	0-20-0	.0010"	.0003"	0.3N	1.750"

Vertical Type



Large Size Dial Face Type

The dial plate size of 2200, 2200B, 2210, and 2210B models has been enlarged, with easy reading due to the larger scale spacing, as a result.



Set Configurations

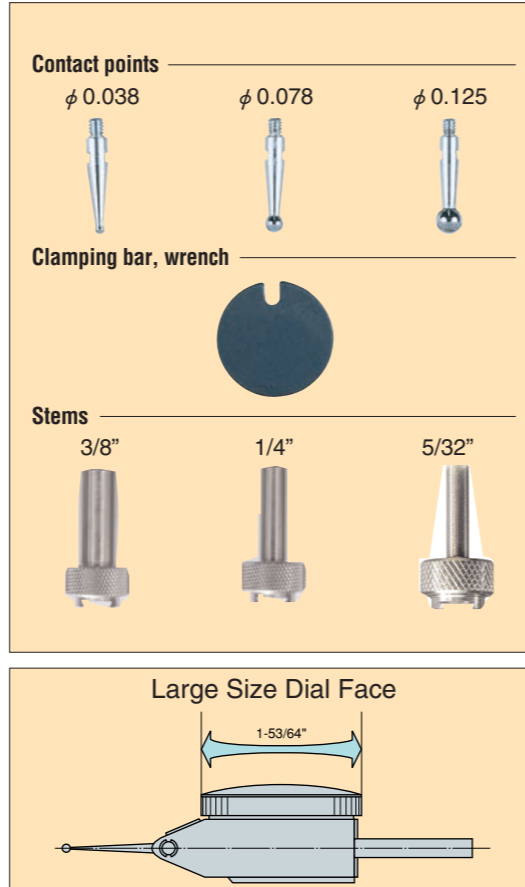

Specifications

White face Model No.	Black face Model No.	Measuring range	Graduation	Reading	Wide range forward accuracy	Backward error	Measuring force (less than)	Contact point length
2050	2050B	.030"	.0005"	0-15-0	.0005"	.0003"	0.3N	.750"
2060	2060B	.008"	.0001"	0-4-0	.0003"	.0002"	0.3N	.375"
2200	2200B	.030"	.0005"	0-15-0	.0005"	.0003"	0.3N	.750"
2210	2210B	.008"	.0001"	0-4-0	.0003"	.0002"	0.3N	.375"

Dial Bore Gage Sets

- Each set includes a high quality ADG2 Dial indicator with .0001" graduations. High precision, combined with ultra smooth movement, makes this the set for the most demanding users.
- Set comes complete with protective cover and fitted case.
- For close tolerance measurements of hole sizes, ID taper dimensions and roundness.
- Each set includes a reference chart, clearly specifying Spacer and Feeler sizes, for each measurement range.



Specifications

White face Model No.	Black face Model No.	Range	Wide range accuracy	Adjacent error	Repeated error	Length below Grip	Number of Feeler	Number of Spacer
5710	5710B	.250-.400"	.0002"	.00008"	.00008"	1-31/32"	8	—
5730	5730B	.370-.750"	.0002"	.00008"	.00008"	3-15/16"	10	1
5740	5740B	.750-1.50"	.0002"	.00008"	.00008"	5-29/32"	8	2
5750	5750B	1.50-2.50"	.0002"	.00008"	.00008"	5-29/32"	6	2
5770	5770B	2.00-6.00"	.0002"	.00008"	.00008"	5-29/32"	11	2
5790	5790B	6.00-10.0"	.0002"	.00008"	.00008"	9-29/32"	9	4

Dial Thickness Gage

- Designed for quick and accurate measurement of small parts, sheet metal, paper, fabric, etc.
- Convenient, one-handed operation.
- Preloaded spindle for consistent measuring pressure.
- Adjustable zero setting with bezel.
- Baked enamel finish.
- Distinct, fine graduations for easy reading.
- Spindle made of hardened steel.



4600
Graduation: 0.001"
Range: 0.5"

Specifications

Model No	Range	Graduation	Throat depth	Accuracy	Measuring force (less than)
4600	.50"	.001"	.78"	.0010"	1.8N



● For measuring thickness of paper

SECTION

5



Gauge Testers

- NB
- CCT-2

5

Gauge Testers

Dial Gauge Automatic Tester Model DGT-20G

When using a dial gauge, it is usually mounted on a jig for inspection. To perform its periodic inspection, it needs a lot of processes more than the other measuring instruments and further time-consuming troublesome works to graph the inspected results are required.

Model "DGT-20G" contributes to decrease such troublesome works extremely.

By only setting a pointer of dial gauge and just turning on a memory switch, gauge testing is automatically made. Everyone can use it with great ease.

1 Easy operation

By only setting a pointer on the scale of dial gauge and just turning on a memory switch, measured data is processed by a micro-computer and its results are automatically printed out.

2 Reducing eye strain

Only fix your eyes to a pointer of dial gauge!
Since you do not read the scale of a gauge tester, measurement for a long time will not tire your eyes.

3 Reducing your inspection time extremely

It can reduce your inspection time from one third to one fifth shorter compared with the conventional method of inspection since this tester has no necessity of reading, recording, and judging the error values.

4 High precision

Usual calibration is not necessary because of the optical glass scale capable of maintaining the stable accuracy with less aged deterioration. Stable inspection is possible because a spindle is not a revolutionary type but a straight one.

5 Register function

Once the measuring range, pitch, and values for judgement are registered, the same measurement can be done just by calling out these items. There include the items already registered by the maker (ROM) and the items manually registered by users (RAM).

6 Manual mode

Measuring items can be set by manual setting. It will be useful for the items that you do not usually use.

Discontinued



Line graph example

- ① Lever-type Dial Gauge
- ② Cylinder Gauge
- ③ Dial Gauge

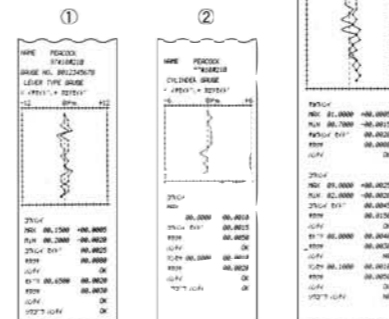

※ Applicable gauges
Dial gauge (based on JIS B 7503)
Special type gauge (based on JIS B 7509)
Lever type gauge (based on JIS B 7533)
Cylinder gauge (based on JIS B 7515)
All of these have to be typical Cylinder gauges with standard probe Depth.

Component Names and Dimensions

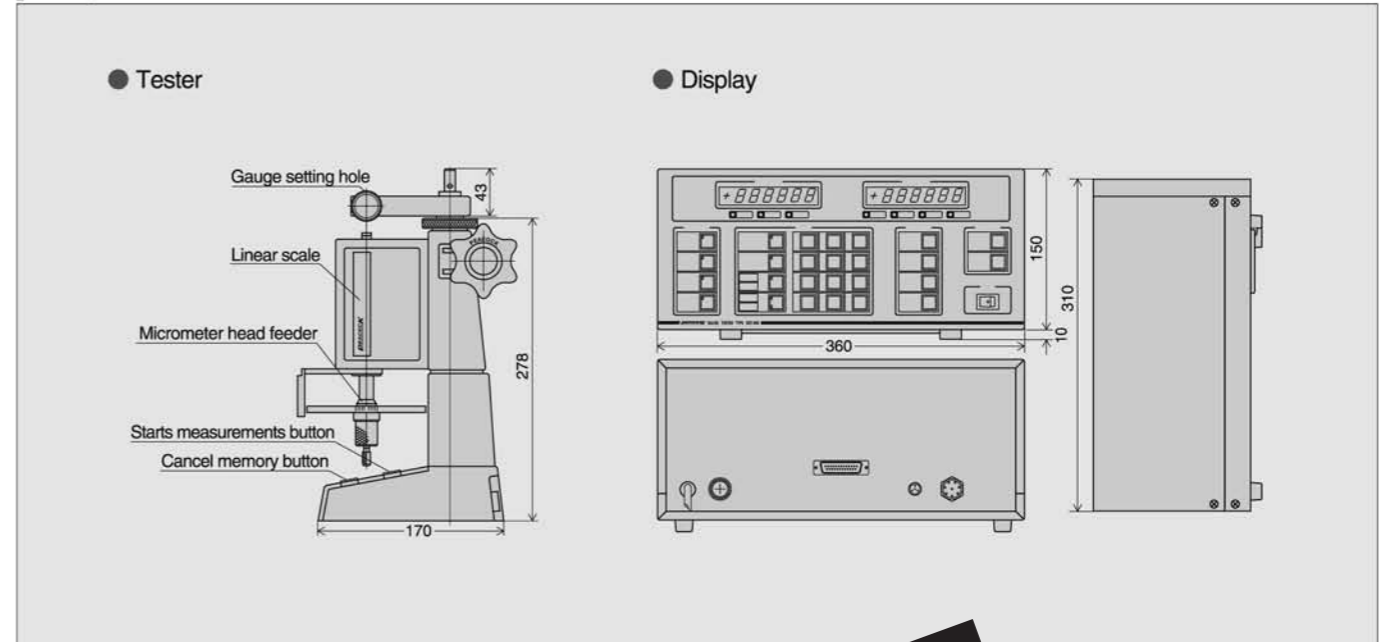

Specifications

Model	
Measuring Range	
Resolution	
Accuracy	±1μm
Standard Scale	Incremental linear scale
Feed Portion	Micrometer head
Display Portion	● Standard value ● Error value
Applicable gauges	● Dial gauges (based on JIS B 7503) ● Lever-type gauges (based on JIS 7533) ● Cylinder gauges (based on JIS B 7515)
Minimum pitch	1μm (0.5μm is impossible)
Maximum input points	200 points
Registered code	24 points
User register code	About 130 points (input by users)
Selection of printing	● Print all data ● Print only results ● Print line graphics
Judgement	By setting the values for judgement, NG value is printed in red letters.
Display function	Standard value is displayed on the left. Error value is displayed on the right. (Narrow range, wide range, or return error is automatically switched.)
Key input function	Measuring date, measuring person, control number, code number (within ten characters)
Preset function	Measuring a long stroke gauge of 20 to 40 mm
Recording paper	Plain paper roll 57X φ 50mm available in the market
Power supply	AC100V · AC220V ±10% 50/60Hz
Standard accessories	● Attachment for lever-type dial gauge.....1 pc. ● Attachment for back plunger dial gauge.....1 pc. ● Mirror (for lever-type dial gauge, Back Plunger type Dial Gauges).....1 pc. ● Connecting code 1 pc., recording paper 1 roll, ink ribbon
Options	● Attachment for cylinder gauge (DGT-CC) ● Attachment for back plunger dial gauge ● Panel in English, Line graph in inch ● Foot-switch (for memory) ● Storing data in a PC, development of software
Data output	● Based on RS-232C output ● Transmit entire data upon test completion ● Connector D-Sub25P

Transmission method	Asynchronous style
baud rate	4800Bps
start bit	1 bit
stop bit	1 bit
code	ASCII 8 bit
parity	none

Discontinued

Gauge Tester

(Dial Indicator Testing Equipment)

Dial Gauge Tester Model NB

- This is a calibration tester having a high precision micrometer with the minimum scale of 1 μ m. It can be used in order to calibrate dial gauges as well as other displacement gauges.
- The stacion is vertically adjustable according to the type of gauges and reading is done while looking at the scale plate and the cursor line.



● Lever-type dial gauge



● Back plunger type dial gauge



Component Names

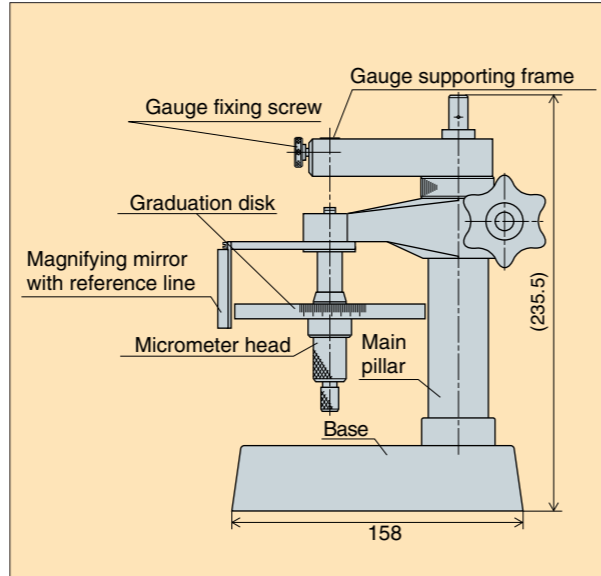

Specifications

Model	Micrometer head		Forward Accuracy (μ m)	Feed per revolution (mm)	Spindle tip	Gauge fixing dimension (mm)
	Graduation (mm)	Measurement Range (mm)				
NB	0.001 (1 μ m)	20	under ± 1	0.5/rev.	Carbide chip	8mm dia. 10mm dia.

Gauge Tester

(Cylinder Gauge Testing Equipment)

Cylinder Gauge Tester Model CCT-2

- This is a calibration tester used exclusively for cylinder gauges having a high precision micrometer with the minimum scale of 1 μ m.
- An outer cylinder is held erectly so that deflection may not affect the measurements and a center rod for pressing is provided on the moving bed in order to prevent from errors due to the difference of measuring force.



● Inspection of dial gauges is also possible.



Cylinder gauges to be possibly inspected

- All the cylinder gauges of JIS B 7515 Standards
- All the CC and CG models of "PEACOCK"

ϕ 6~10mm	ϕ 18~35mm	ϕ 50~100mm	ϕ 160~250mm
ϕ 10~18mm	ϕ 35~60mm	ϕ 100~160mm	ϕ 250~400mm

Component Names

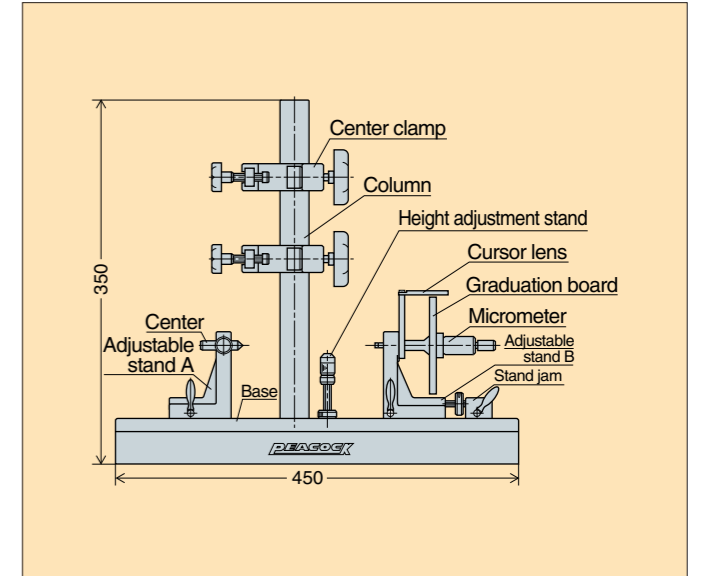

Specifications

Model	Micrometer head		Forward Accuracy (μ m)	Feed per revolution (mm)	Spindle tip
	Graduation (mm)	Measurement Range (mm)			
CCT-2	0.001	20	under ± 1	0.5/rev.	Carbide chip

MEMO

A series of horizontal dotted lines for writing, consisting of 15 lines spaced evenly down the page.



Thickness Gauges

- Dial Thickness Gauges (0.01mm, 0.001mm)
- Dial Swift Gauge
- Pearl Scale
- Snap Caliper
- Dial Thickness Gauges (Large Type) (0.01mm, 0.05mm)
- Dial Lens Gauge
- Dial Sheet Gauges (0.01mm, 0.05mm)
- Dial Pipe Gauges
- Dial Thickness Gauge (Roller Type)
- Dial Upright Gauges
- Constant Pressure Thickness Gauge

Dial Thickness Gauges

0.01mm type

These thickness gauges are especially handy for measuring thickness of small parts, metal, rubber, vinyl, paper, foil and other sheet material.

- The objects to be measured is clamped by simple lever operation. The measured values are read directly on the dial gauge.
- Since the anvil and the contact point are adjusted for parallelism, accurate measured values are obtained.

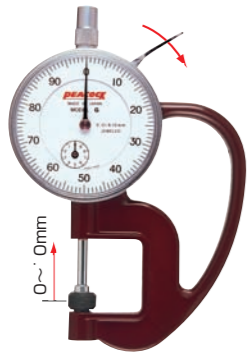

G
Graduation: 0.01mm
Range: 0~10mm

- ϕ 10mm flat contact point and anvil (Ceramic)



G-0.4N
Graduation: 0.01mm
Range: 0~10mm

- Measuring force initial pressure 0.4N



G-2.4N
Graduation: 0.01mm
Range: 0~10mm

- Measuring force final pressure 2.4N



G-20
Graduation: 0.01mm
Range: 0~10mm

- ϕ 20mm flat contact point and anvil (Metal)



G-30
Graduation: 0.01mm
Range: 0~10mm

- ϕ 30mm flat contact point and anvil (Metal)



G-1A
Graduation: 0.01mm
Range: 0~10mm

- ϕ 5mm flat contact point and anvil (Metal)



G-1M
Graduation: 0.01mm
Range: 0~10mm

- ϕ 6mm flat contact point and anvil (Ceramic)

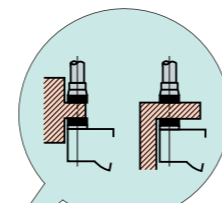

● The frame on the anvil side is cut, which to be flush contact point, anvil and frame.

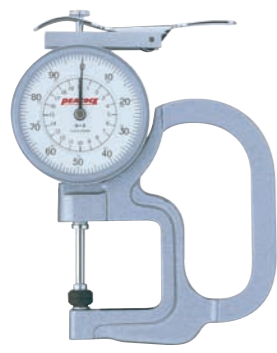

G-2
Graduation: 0.01mm
Range: 0~20mm

- ϕ 10mm flat contact point and anvil (Ceramic)



G-3
Graduation: 0.01mm
Range: 30mm

- ϕ 10mm flat contact point and anvil (Ceramic)
- Anvil side is adjustable
- More than 10mm range is comparative measurement.

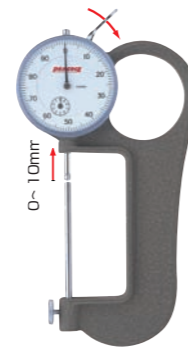

G-4
Graduation: 0.01mm
Range: 65mm

- Spherical contact point
- Anvil side is adjustable
- More than 10mm range is comparative measurement.

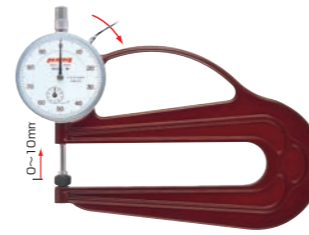

H
Graduation: 0.01mm
Range: 0~10mm

- ϕ 10mm flat contact point and anvil (Ceramic)



H-0.4N
Graduation: 0.01mm
Range: 0~10mm

- Measuring force initial pressure 0.4N



H-2.4N
Graduation: 0.01mm
Range: 0~10mm

- Measuring force final pressure 2.4N



H-20
Graduation: 0.01mm
Range: 0~10mm

- ϕ 20mm flat contact point and anvil (Metal)



H-30
Graduation: 0.01mm
Range: 0~10mm

- ϕ 30mm flat contact point and anvil (Metal)



H-1A
Graduation: 0.01mm
Range: 0~10mm

- ϕ 5mm flat contact point and anvil (Metal)

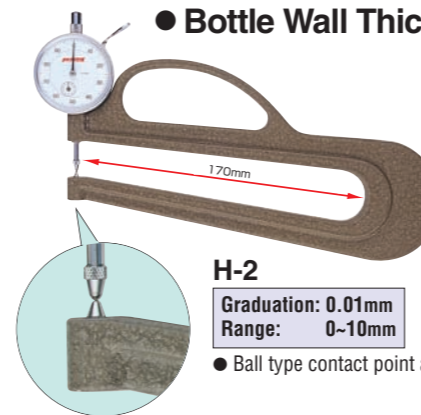

● Bottle Wall Thickness Gauge

H-2
Graduation: 0.01mm
Range: 0~10mm

- Ball type contact point and anvil

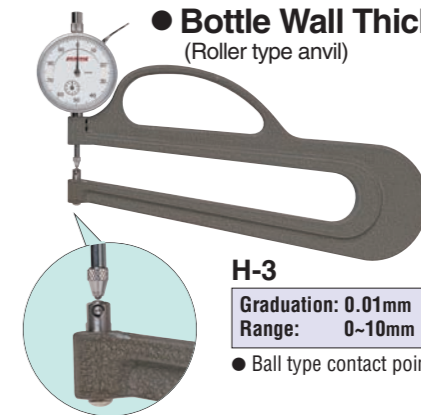

● Bottle Wall Thickness Gauge (Roller type anvil)

H-3
Graduation: 0.01mm
Range: 0~10mm

- Ball type contact point and roller type anvil

Specifications

Model	Graduation (mm)	Range (mm)	Throat depth (mm)	Accuracy (μ m)	Contact Point		Measuring force less than(N)
					Dia (mm)	Parallelism (μ m)	
G	0.01	0~10	20	± 20	10	5	1.8
G-0.4N	0.01	0~10	20	± 20	10	5	Initial pressure 0.4N
G-2.4N	0.01	0~10	20	± 20	10	5	Final pressure 2.4N
G-MT	0.01	0~10	20	± 20	10 (Metal)	5	1.8
G-1A	0.01	0~10	20	± 20	5	5	1.8
G-1M	0.01	0~10	20	± 20	6	5	1.8
G-2	0.01	0~20	33	± 22	10	5	2.0
* G-3	0.01	30	20	± 20	10	5	1.8
* G-4	0.01	65	30	± 20	Spherical	—	1.8
G-20	0.01	0~10	20	± 20	20 (Metal)	15	1.8
G-30	0.01	0~10	20	± 20	30 (Metal)	20	1.8
H	0.01	0~10	120	± 20	10	5	1.8
H-0.4N	0.01	0~10	120	± 20	10	5	Initial pressure 0.4N
H-2.4N	0.01	0~10	120	± 20	10	5	Final pressure 2.4N
H-MT	0.01	0~10	120	± 20	10 (Metal)	5	1.8
H-1A	0.01	0~10	120	± 20	5	5	1.8
H-2	0.01	0~10	170	± 20	Ball type	—	1.8
H-3	0.01	0~10	170	± 20	Ball type	—	1.8
H-20	0.01	0~10	120	± 20	20 (Metal)	15	1.8
H-30	0.01	0~10	120	± 20	30 (Metal)	20	1.8

* G-3/G-4 : Measuring range of dial gauge is 10mm.

Dial Thickness Gauges

0.001mm type PAT. No. 3052674

- New thickness gauges with 0.001mm graduations.
- Newly developed special frame minimizes inspecting errors resulting from thermal changes. Zero reference point will remain accurate even after many hours of use or extreme swings in temperature.



G-6C
Graduation: 0.001mm
Range: 0~1mm

- ϕ 5mm flat contact point and anvil (Metal)

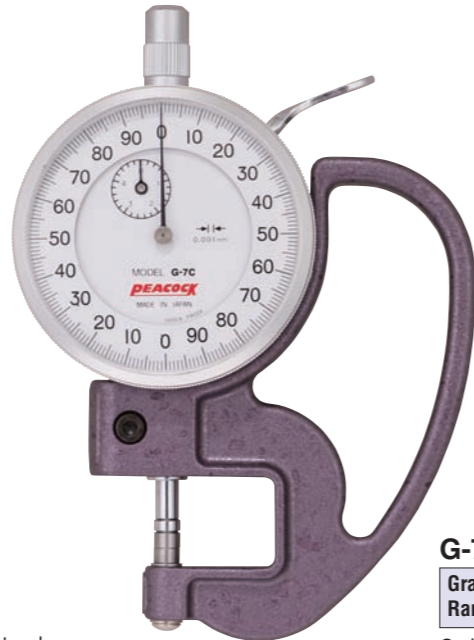

G-7C
Graduation: 0.001mm
Range: 0~5mm

- ϕ 5mm flat contact point and anvil (Metal)

Specifications

Model	Graduation (mm)	Range (mm)	Throat depth (mm)	Accuracy (μ m)	Contact Point		Measuring force less than (N)
					Dia (mm)	Parallelism (μ m)	
G-6C	0.001	0~1	20	± 5	5	3	1.8
G-7C	0.001	0~5	20	± 10	5	3	1.8

Dial Swift Gauge

The dial swift gauge is used for the same purpose as an ordinary micrometer to measure outside sizes.

- The spindle is always pulled upward by the force of the spring. The knob at the top of the gauge is pushed down by finger to clamp an object in measurement.
- It will show its power for measurement of thickness, heights and diameters.



Q-1
Graduation: 0.05mm
Range: 0~25mm

Specifications

Model	Graduation (mm)	Range (mm)	Throat depth (mm)	Accuracy (μ m)	Contact Point	
					Dia (mm)	Parallelism (μ m)
Q-1	0.05	0~25	30	± 100	5.5	10

Pearl Scale

Handy Size: "Pearl Scale" is compact and light.

It is so handy that you can either hang it from your neck or carry it in a pocket.

Easy Measurement: You can measure size or thickness of an object you want to measure, just by holding it between a contact point and anvil, and pressing a knob lightly by your finger. A division of scale shows 0.1mm, and you can measure up to 20mm by this gauge.



PS-1
Graduation: 0.1mm
Range: 20mm



A knob is up when a gauge is released. You only have to press a knob to make a quick measurement.

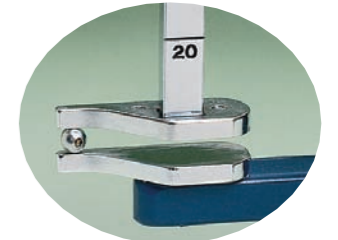

Since the tips of contact point and anvil are narrowed, you can hold even a small object by your fingers for measurement.



Since the back of gauge is flat, you can measure an object, while laying your gauge on a desk or table.



With 0.1mm graduation of a gauge, you can easily read measured values, which makes your work more efficient.

Snap Calipers

- Easy measurement of thickness, outer diameter, inner diameter and depth.
- Handy size with excellent functions.
- Minimum reading : 0.1mm.



EG-1
for measurement of inner diameter and outer diameter.

Graduation: 0.1mm
Measurement of thickness: 0-20mm
Measurement of inner diameter: 3-23mm
Measurement of depth: 0-20mm
(※EG-2 only)



EG-2
for measurement of inner diameter, outer diameter and depth.

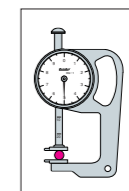

To measure thickness and diameter of balls.

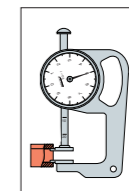

To measure groove width and inner diameter.

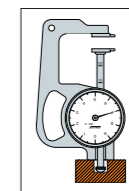

To measure depth and step depth. (EG-2 only.)

Dial Thickness Gauges (Large type)

These large thickness gauges having extended throat depth to measure at the center of wide sheets.

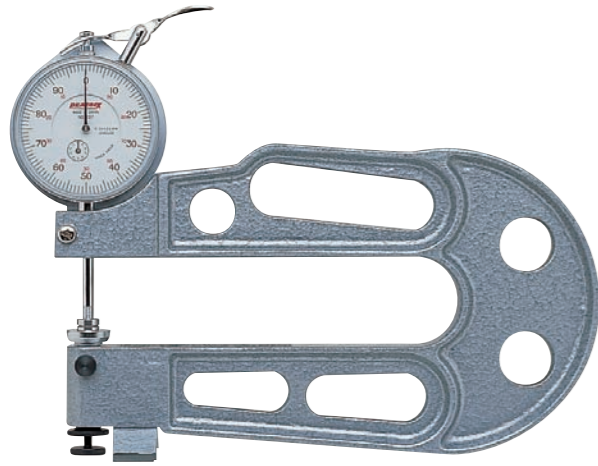

J-A

Graduation: 0.01mm
Range: 0~20mm

- The gauge sits by stand
- ϕ 10mm flat contact point and ϕ 20mm anvil (Metal)

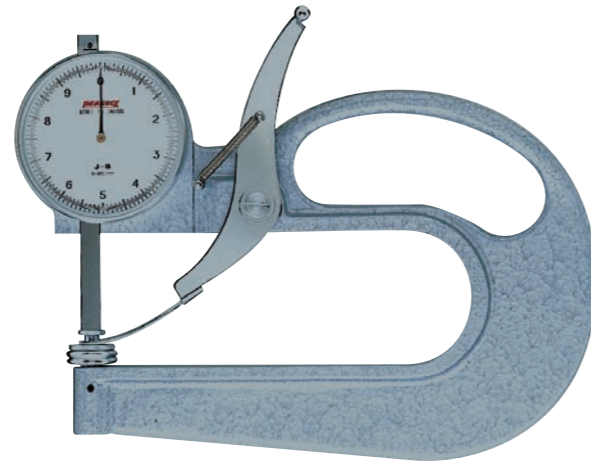

J-B

Graduation: 0.05mm
Range: 0~35mm

- ϕ 20mm flat contact point and anvil (Metal)

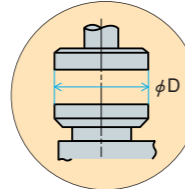

Custom order available

Optional ϕ 30,40 and 50mm contact points and anvils are available. Please specify material for contact point and anvil, either Metal (SK) material or aluminum (AL).

Specifications

Model	Graduation (mm)	Range (mm)	Throat depth (mm)	Accuracy (μ m)	Contact Point		Measuring force less than (N)
					Dia (mm)	Parallelism (μ m)	
J-A	0.01	0~20	150	\pm 22	10	5	2.0
J-B	0.05	0~35	140	\pm 100	20	25	3.0

Dial Thickness Gauge Roller type

Special gauges for measuring of horizontally sliding a gauge with an object to be in inspected laid since the contact point and anvil are made with the roller. Convenient to continuously measuring thickness of thin objects, paper, rubber and film etc.



HR-1

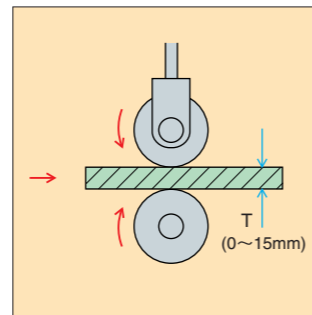

Specifications

Model	Graduation (mm)	Range (mm)	Throat depth (mm)	Accuracy (μ m)	Roller contact points			Measuring force less than (N)
					OD (mm)	Width (mm)	Parallelism (μ m)	
HR-1	0.01	0~15	70	\pm 22	22	7	10	2.0

Dial Sheet Gauges

0.01mm and 0.05mm

- The sheet gauges can measure wide sheets since the throat depth of this gauges having 300, 500 and 690mm.

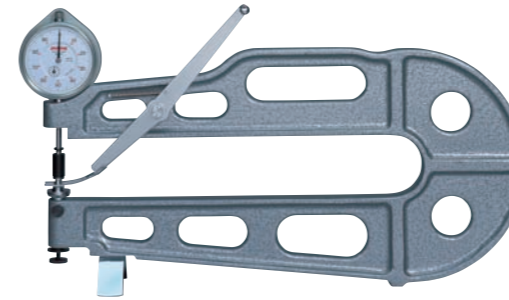

K-1

Graduation: 0.01mm
Range: 0~20mm

- ϕ 10mm flat contact point and ϕ 20mm anvil (Metal)

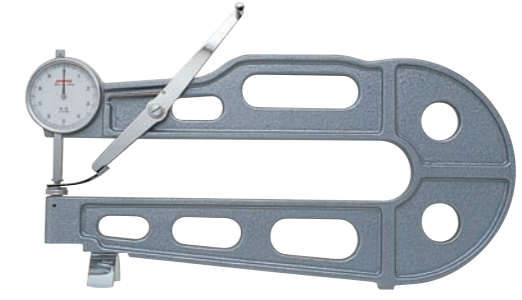

K-2

Graduation: 0.05mm
Range: 0~35mm

- ϕ 20mm flat contact point and anvil (Metal)

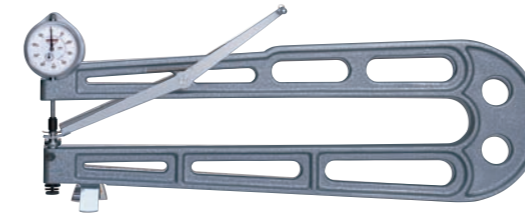

K-3

Graduation: 0.01mm
Range: 0~20mm

- ϕ 10mm flat contact point and ϕ 20mm anvil (Metal)



K-4

Graduation: 0.05mm
Range: 0~50mm

- ϕ 25mm flat contact point and anvil (Metal)

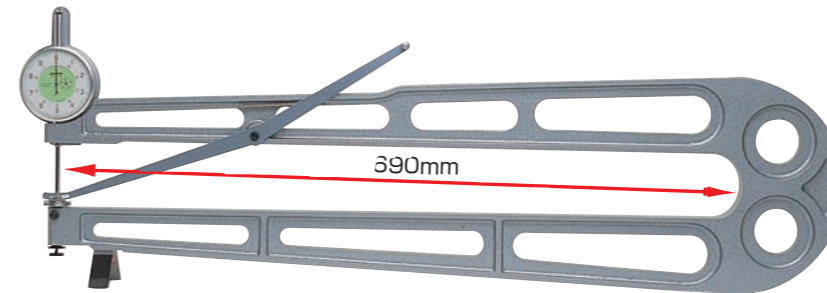

K-7 (Production on request)

Graduation: 0.05mm
Range: 0~50mm

- ϕ 30mm flat contact point and anvil (Metal)

Custom order available

Optional ϕ 30,40 and 50mm contact points and anvils are available. Please specify material for contact point and anvil, either Metal (SK) material or aluminum (AL).

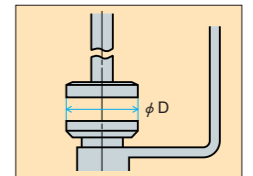

Specifications

Model	Graduation (mm)	Range (mm)	Throat depth (mm)	Accuracy (μ m)	Contact Point		Measuring force less than (N)
					Dia (mm)	Parallelism (μ m)	
K-1	0.01	0~20	300	\pm 22	10	10	2.0
K-2	0.05	0~35	300	\pm 100	20	25	3.0
K-3	0.01	0~20	500	\pm 22	10	10	3.0
K-4	0.05	0~50	500	\pm 100	25	25	3.0
K-7	0.05	0~50	690	\pm 100	30	25	3.0

※ Model K-7 is production on request.



Dial Pipe Gauges

Special gauges for measuring wall thickness of pipes.

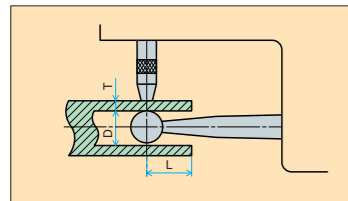
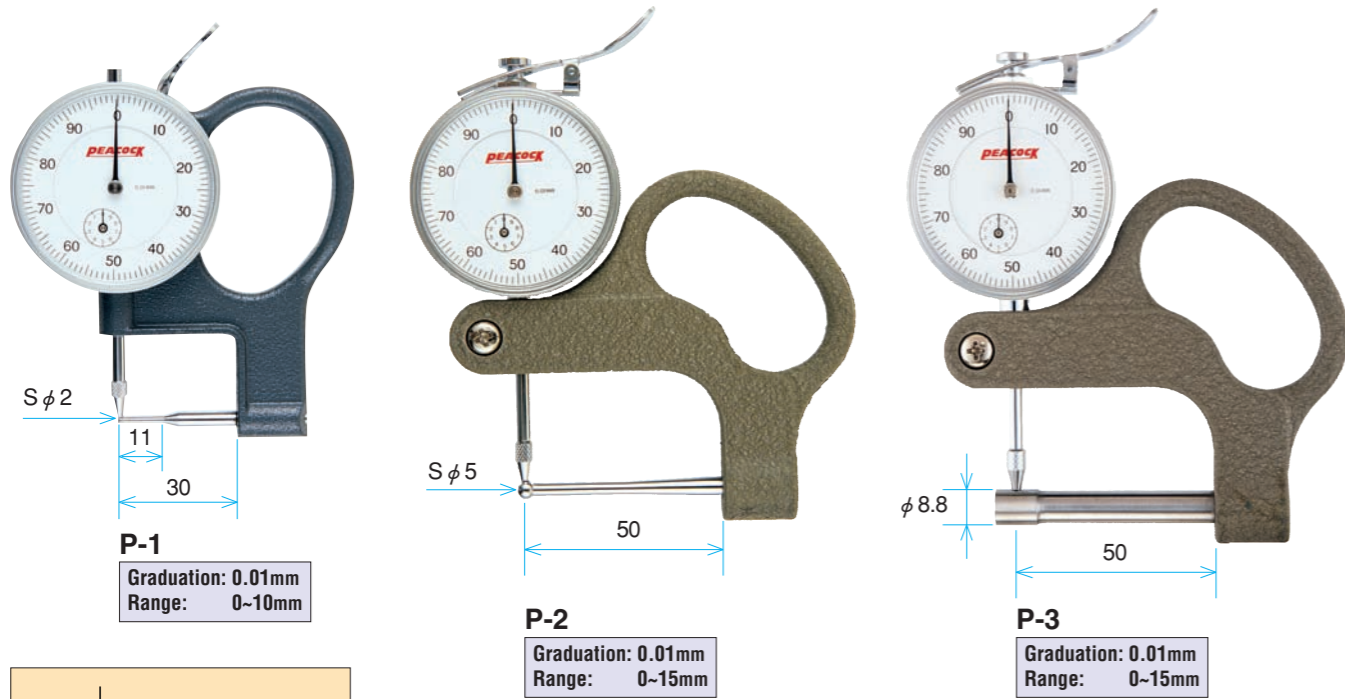

Specifications

Model	Graduation (mm)	Range (mm)	Accuracy (μm)	Pipe size measurable (mm)			Measuring force less than (N)
				Minimum bore D	Maximum wall thickness T	Depth L	
P-1	0.01	0~10	±20	2.5	10	10	1.8
P-2	0.01	0~15	±22	5.1	15	50	1.8
P-3	0.01	0~15	±22	9.0	15	50	1.8

Dial Lens Gauge

The dial lens gauge can measure convex, concave, convexo-concave and any other lenses in the same gauge by replacing the two contact points and the anvil.

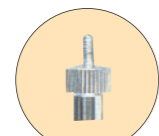

Replaceable Flat contact point (Standard accessory)

Applied examples

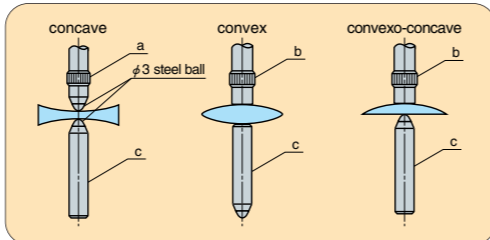

GL
Graduation: 0.01mm
Range: 10mm

Specifications

Model	Graduation (mm)	Range (mm)	Accuracy (μm)	Throat depth (mm)	maximum lens diameter measurable (mm)	maximum lens thickness measurable (mm)	Measuring force less than (N)
GL	0.01	10	±20	30	φ 59	※ 20	1.8

※ Anvil side is adjustable.

Dial Thickness Gauge (Special Order)

● Snap type (Spindle is manually pushed down)

We manufacture with low or high measuring force according to your needs.

- Maximum Measuring force under 2.4N (240gf)
- Minimum Measuring force over 0.4N (40gf)

Please specify the desired Measuring force.

- Lever type (example of use)
- For measuring thickness of hair
- For measuring thickness of paper
- For different applications, the shape of the contact point and anvil can be special ordered.
 - Dial face with personal logo
 - Special order dial faces

Examples of modification for contact point and anvil

- Both Contact Point and Anvil needle type**
Please specify φ D
- Both Contact Point and Anvil ball type**
S φ 2.4
- Both Contact Point and Anvil are 20mm diameter flat type**
(also available in φ 25 and 30mm)
Please specify D
- Both Contact Point and Anvil are horizontal blade type**
Please specify φ D and thickness.
- Both Contact Point and Anvil are vertical blade type**
Please specify φ D and thickness.
- Needle type Contact Point and Flat type Anvil.**
D = 10mm diameter (also available in φ 20, 25 and 30mm)
- Ball type Contact Point and Flat type Anvil.**
D = 10mm diameter (also available in φ 20, 25 and 30mm)

Dial Upright Gauges

R series

Best suited for measuring precision parts and testing materials like rubber, leather, fabric and plastic etc. Rubber, leather, urethane and film can be easily measured by this system.

- The table of R1 series are adjustable up and down by the nut installed side way.
- The dial gauge is affixed to the body.



R1-A
Graduation: 0.001mm
Range: 2mm
Effective measuring range: 10mm



R1-B
Graduation: 0.01mm
Range: 10mm
Effective measuring range: 25mm



R1-C
Graduation: 0.01mm
Range: 20mm
Effective measuring range: 20mm

Specifications

Model	Dial Indicator (standard attachments)			Indication error (μm)	Table diameter (mm)	Contact point dia. (mm)	Measuring force less than (N)	Measuring depth (mm)	Effective measuring range (mm)	Total height (mm)
	Gauge installed	Range (mm)	Graduation (mm)							
R1-A	25F-RE	2	0.001	±7	40	5	1.5	55	10	191
R1-B	107F-RE	10	0.01	±15	40	5	1.4	55	25	190
R1-C	207F-PL	20	0.01	±22	40	5	2.0	55	20	210

Constant Pressure Thickness Gauges (Special Order)

- Constant Pressure Thickness Gauges can be made to comply with JIS by attaching exact weights that create the specific pressures needed to measure different materials.
- Three types (FFG. FFA. FFD series) are available to meet your measurement.

Compact Handy type FFG series (PAT.No.3073347)



Measuring material	JIS No.	Applied Model
Shrink package film	Z1709	FFG-1
Polyethylene package film	Z1702	FFG-1
Ethylene film	K6783	FFG-1
Polyvinyl chloride film	K6732	FFG-2
Leather	K6328	FFG-4
Vulcanized rubber / Thermoplastic rubber (Hardness 35IRHD less)	K6250A	FFG-5
Vulcanized rubber / Thermoplastic rubber (Hardness 35IRHD less)	K6250A	FFG-6
Vulcanized rubber / Thermoplastic rubber (Hardness 35IRHD more)	K6250A	FFG-7
Vulcanized rubber / Thermoplastic rubber (Hardness 35IRHD more)	K6250A	FFG-8
Urethane form	K6402	FFG-9
Common fabric (basic / fuzzy material)	L1096	FFG-11
Adhesive interlined cloth (common weave / common knit / non-woven)	L1086	FFG-11
Stockinet (common knit)	L1018	FFG-11
Unwoven / interlined cloth	L1085	FFG-12
Adhesive interlined cloth (non-woven)	L1086	FFG-12

Specifications

Model	Graduation (mm)	Range (mm)	Indication error (μmm)	Throat depth (mm)	Contact Point dia (ømm)	Anvil dia (ømm)	Measuring force N(gf)	Parallelism (μm)
FFG-1	0.001	2	±10	24	5	30	1.25±0.15 (125±15)	5
FFG-2	0.001	2	±10	24	5	30	less than 0.8 (less than 80)	5
FFG-4	0.01	10	±22	24	10	30	less than 0.8 (less than 80)	7
FFG-5	0.01	7	±22	24	5 (19.625mm²)	30	0.2±0.04 (20±4)	5
FFG-6	0.01	10	±22	24	8 (50.24mm²)	30	0.51±0.1 (51±10)	7
FFG-7	0.01	10	±22	24	5 (19.625mm²)	30	0.44±0.1 (44±10)	5
FFG-8	0.01	10	±22	24	8 (50.24mm²)	30	1.13±0.26 (113±26)	7
FFG-9	0.01	10	±22	24	35.7 (10cm²)	40	less than 0.37 (less than 37)	25
FFG-11	0.01	10	±22	24	25.2 (5cm²)	30	less than 0.35 (less than 35)	20
FFG-12	0.01	10	±22	24	16 (2cm²)	30	less than 0.4 (less than 40)	15

Constant Pressure Thickness Gauges (Order)

Stand type FFA series



FFA-7

Measuring material	JIS No.	Applied Model
Shrink package film	Z1709	FFA-1
Polyethylene package film	Z1702	FFA-1
Ethylene film	K6783	FFA-1
Polyvinyl chloride film	K6732	FFA-2
Leather	K6550	FFA-3
Artificial leather	K6505	FFA-3
Sheet rubber	K6328	FFA-4
Vulcanized rubber / Thermoplastic rubber (Hardness 35IRHD less)	K6250A	FFA-5
Vulcanized rubber / Thermoplastic rubber (Hardness 35IRHD less)	K6250A	FFA-6
Vulcanized rubber / Thermoplastic rubber (Hardness 35IRHD more)	K6250A	FFA-7
Vulcanized rubber / Thermoplastic rubber (Hardness 35IRHD more)	K6250A	FFA-8
Urethane form	K6402	FFA-9
Common fabric (basic / fuzzy material)	L1096	FFA-10
Adhesive interlined cloth (common weave / common knit / non-woven)	L1086	FFA-10
Common fabric (basic / fuzzy material)	L1096	FFA-11
Stockinet (common knit)	L1018	FFA-11
Unwoven / interlined cloth	L1085	FFA-12
Adhesive interlined cloth (non-woven)	L1086	FFA-12
Tensile properties of plastics	K7113	FFA-13

Specifications

Model	Graduation (mm)	Range (mm)	Indication error (μm)	Throat depth (mm)	Contact Point dia (ømm)	Anvil dia (ømm)	Spindle lifting	Stand type	Measuring force N(gf)	Parallelism (μm)
FFA-1	0.001	2	±8	55	5	40	Lever	R1 type	1.25±0.15 (125±15)	5
FFA-2	0.001	2	±8	55	5	40	Release	R1 type	less than 0.8 (less than 80)	5
FFA-3	0.01	10	±20	55	10	50	Lever	SIS-6C special	3.93±0.1 (393±10)	10
FFA-4	0.01	10	±20	55	10	50	Release	SIS-6C	less than 0.8 (less than 80)	7
FFA-5	0.01	7	±20	55	5 (19.625mm²)	50	Release	SIS-6C	0.2±0.04 (20±4)	5
FFA-6	0.01	10	±20	55	8 (50.24mm²)	50	Release	SIS-6C	0.51±0.1 (51±10)	7
FFA-7	0.01	10	±20	55	5 (19.625mm²)	50	Release	SIS-6C	0.44±0.1 (44±10)	5
FFA-8	0.01	10	±20	55	8 (50.24mm²)	50	Lever	SIS-6C	1.13±0.26 (113±26)	7
FFA-9	0.01	10	±20	55	35.7 (10cm²)	50	Release	SIS-6C	less than 0.37 (less than 37)	25
FFA-10	0.01	10	±20	55	11.3 (1cm²)	50	Lever	SIS-6C	less than 2.4 (less than 240)	10
FFA-11	0.01	10	±20	55	25.2 (5cm²)	50	Release	SIS-6C	less than 0.35 (less than 35)	20
FFA-12	0.01	10	±20	55	16 (2cm²)	50	Release	SIS-6C	less than 0.4 (less than 40)	15
FFA-13	0.01	10	±20	55	10 (78.5cm²)	50	Lever	SIS-6C	less than 1.57 (less than 157)	7

Digital type FFD series (with data output)



FFD-1

Measuring material	JIS No.	Applied Model
Shrink package film	Z1709	FFD-1
Polyethylene package film	Z1702	FFD-1
Ethylene film	K6783	FFD-1
Polyvinyl chloride film	K6732	FFD-2
Leather	K6550	FFD-3
Artificial leather	K6505	FFD-3
Sheet rubber	K6328	FFD-4
Vulcanized rubber / Thermoplastic rubber (Hardness 35IRHD less)	K6250A	FFD-6
Vulcanized rubber / Thermoplastic rubber (Hardness 35IRHD more)	K6250A	FFD-7
Vulcanized rubber / Thermoplastic rubber	K6250A	FFD-8
Common fabric (basic / fuzzy material)	L1096	FFD-10
Adhesive interlined cloth (common weave / common knit / non-woven)	L1086	FFD-10
Tensile properties of plastics	K7113	FFD-13

Specifications

Model	Range (mm)	Indication error (μm)	Graduation (mm)	Display	Power supply	Data output	Throat depth (mm)	Contact Point dia (ømm)	Anvil dia (ømm)	Measuring force N(gf)	Parallelism (μm)
FFD-1	20	±4	0.001	5digit	AC Adapter (100V to 240V)	RS-232C	55	5	40	1.25±0.15 (125±15)	5
FFD-2	20	±4	0.001				55	5	40	less than 0.8 (less than 80)	5
FFD-3	20	±20	0.01	4digit			55	10	50	3.93±0.1 (393±10)	10
FFD-4	20	±20	0.01				55	10	50	less than 0.8 (less than 80)	10
FFD-6	20	±20	0.01				55	8 (50.24mm²)	50	0.51±0.1 (51±10)	10
FFD-7	20	±20	0.01				55	5 (19.625mm²)	50	0.44±0.1 (44±10)	10
FFD-8	20	±20	0.01				55	8 (50.24mm²)	50	1.13±0.26 (113±26)	10
FFD-10	20	±20	0.01				55	11.3 (1cm²)	50	less than 2.4 (less than 240)	10
FFD-13	20	±20	0.01				55	10 (78.5mm²)	50	less than 1.57 (less than 157)	10

Special Order Available

FFG Series

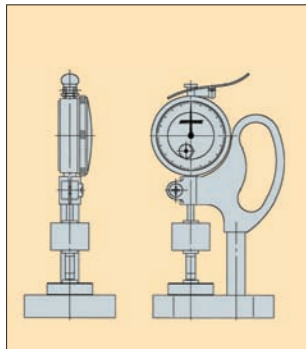

Handy type

FFA Series

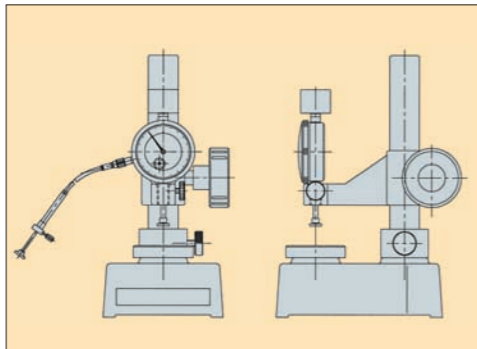

Stand type

FFD Series

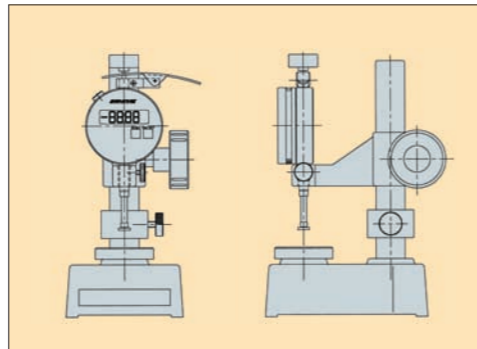

Digital type

Please specify what you want to measure as following:

1. Material of measurement work-piece:

2. JIS Standard No. or its equivalent standard:

3. Resolution: 0.01mm, 0.001mm

4. Measuring force:

5. Diameter of Contact Point (ex. $\phi 5$, $\phi 10$ mm)

6. Type of Constant Pressure Thickness Gauge

Please check

FFG Handy type

FFA Stand type

FFD Digital type

7. Other requirement:

SECTION

7

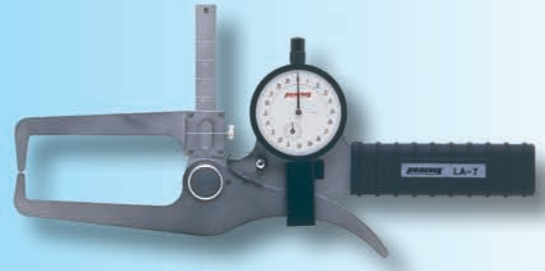

Dial Caliper Gauges

- LA Series -Outside-
- LB Series -Inside-

7

Dial Calipers

LA series (Outside measuring of ODs and thicknesses)

The dial caliper gauge show its great power in measurement of inside and outside sizes, wall thickness, groove width and hole diameters and any other shapes and sections that is not apparently accessible.



LA-1
Graduation: 0.1mm
Range: 0~80mm
Throat depth: 120mm

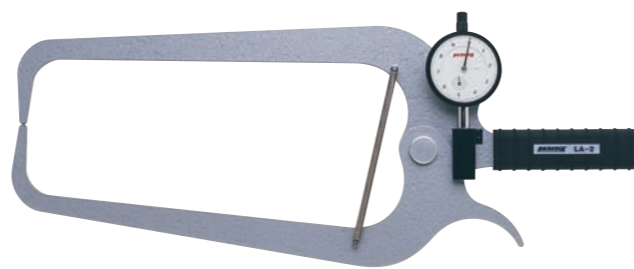

LA-2
Graduation: 0.1mm
Range: 0~80mm
Throat depth: 240mm

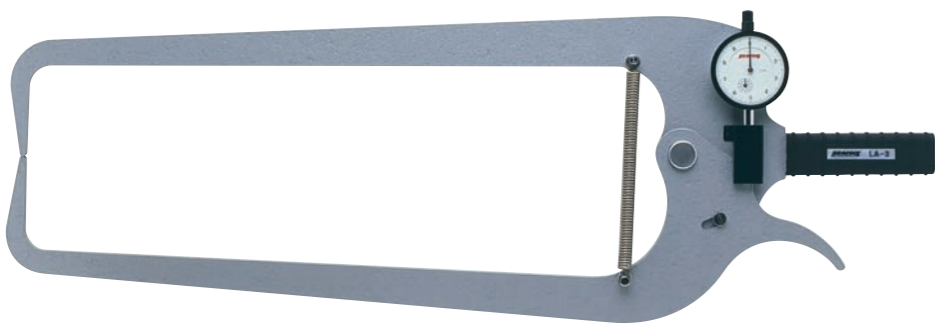

LA-3
Graduation: 0.1mm
Range: 0~80mm
Throat depth: 400mm



LA-4
Graduation: 0.05mm
Range: 0~50mm
Throat depth: 90mm

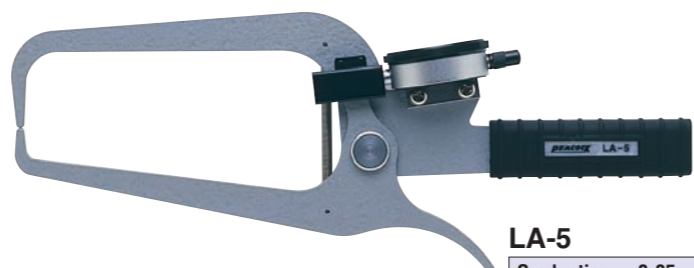

LA-5
Graduation: 0.05mm
Range: 0~50mm
Throat depth: 150mm



LA-6
Graduation: 0.01mm
Range: 0~10mm
Throat depth: 60mm

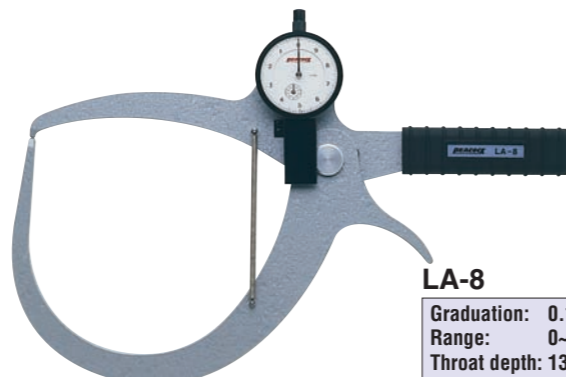

LA-8
Graduation: 0.1mm
Range: 0~80mm
Throat depth: 130mm



LA-7
Graduation: 0.01mm
Range: 0~60mm
Throat depth: 85mm

- Adjustable frame
- The LA-7 can measure an absolute value in a measuring range of 10 mm
- It allows measurement of comparative values in more than 10 mm

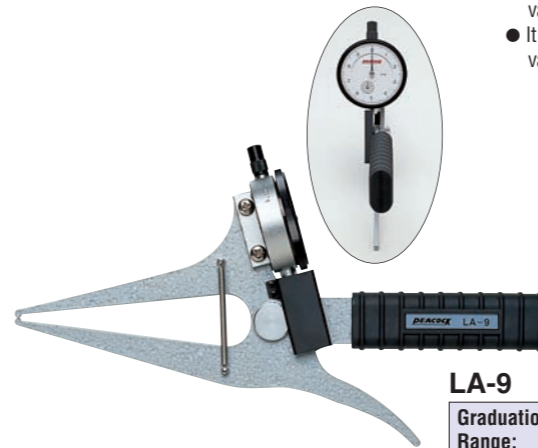

LA-9
Graduation: 0.1mm
Range: 0~30mm
Throat depth: 100mm



LA-10
Graduation: 0.01mm
Range: 0~20mm
Throat depth: 100mm

- The tip of the bottom frame \varnothing 10mm Flat Rocking Contact Point.

Applied Example - outside -

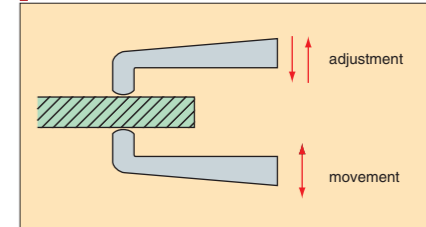

Note: Throat Depth is changed by Measuring Range.
Contact us more detailed information.

Ex. LA-13

Range	Throat Depth
0~ 50mm	235mm
0~ 60mm	125mm
0~ 80mm	102mm
0~100mm	91mm
0~130mm	86mm

Specifications

Model	Graduation (mm)	Range (mm)	Indication error (mm)	Throat depth (mm)	Dimensions (mm)			
					H1	H2	H3	H4
LA-1	0.1	0~80	±0.2	120	25	40	25	40
LA-2	0.1	0~80	±0.2	240	48	57	48	57
LA-3	0.1	0~80	±0.2	400	60	60	58	79
LA-4	0.05	0~50	±0.15	90	30	40	30	40
LA-5	0.05	0~50	±0.15	150	38	57	15	21
LA-5S	0.05	0~10	±0.15	120	1.5	10	34	34
LA-6	0.01	0~10	±0.03	60	2.5	18	2.5	18
LA-7	0.01	0~60	±0.03	85	20	20	15	15
LA-8	0.1	0~80	±0.2	130	—	—	—	—
LA-9	0.1	0~30	±0.2	100	2	12	2	12
LA-10	0.01	0~20	±0.03	100	28	28	28	28

Dial Calipers



LA-11
Graduation: 0.1mm
Range: 0~50mm
Throat depth: 125mm

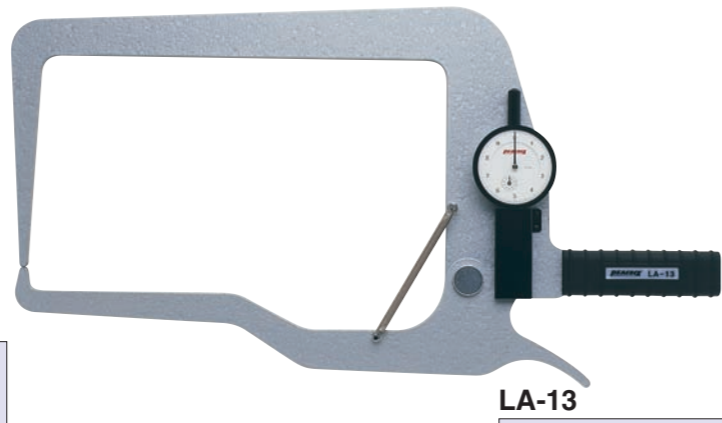

LA-13
Graduation: 0.1mm
Range: 0~130mm
※ Throat depth: 235mm
※ see page 101



LA-14
Graduation: 0.01mm
Range: 100~150mm
Throat depth: 70mm
● LA-14 is for comparative measurement.



LA-20
Graduation: 0.1mm
Range: 0~80mm
Throat depth: 125mm

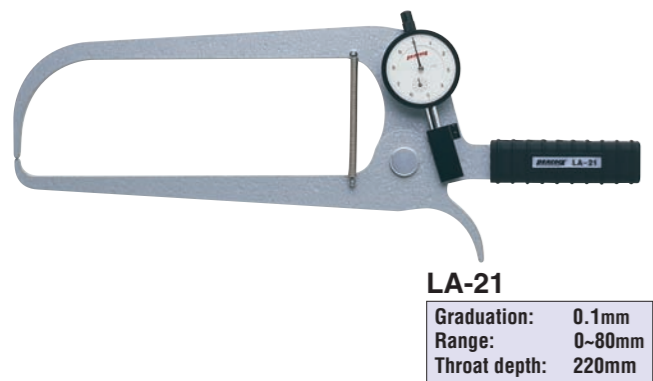

LA-21
Graduation: 0.1mm
Range: 0~80mm
Throat depth: 220mm

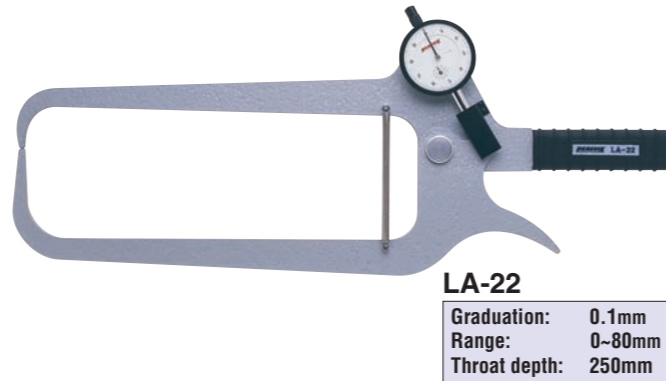

LA-22
Graduation: 0.1mm
Range: 0~80mm
Throat depth: 250mm

Name of parts

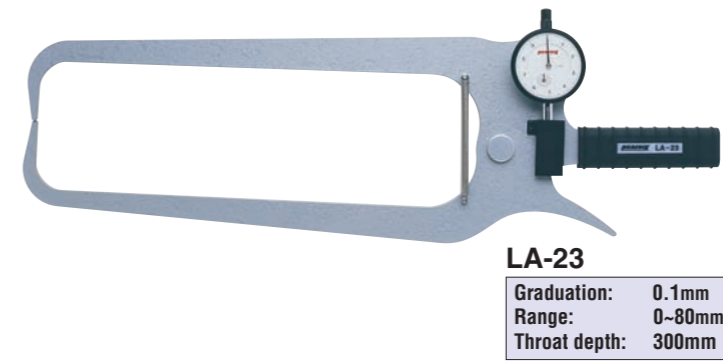
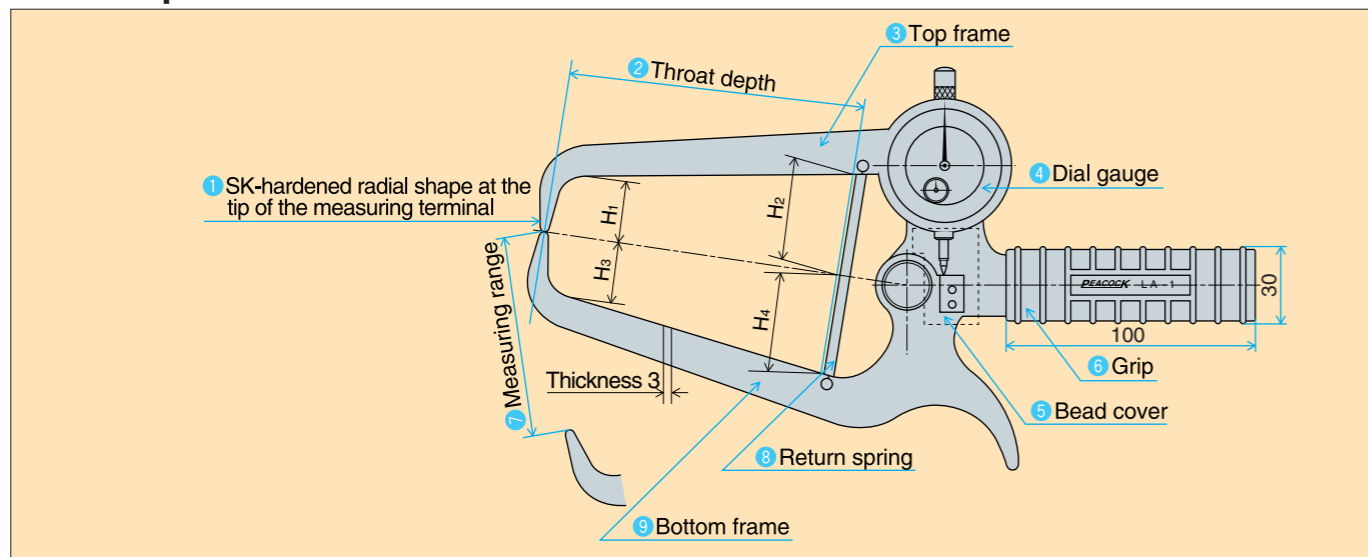

LA-23
Graduation: 0.1mm
Range: 0~80mm
Throat depth: 300mm



LA-31
Graduation: 0.01mm
Range: 0~20mm
Throat depth: 125mm

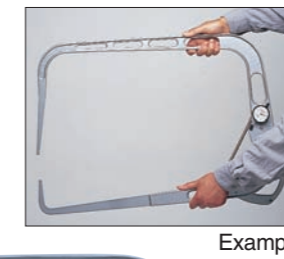

Example

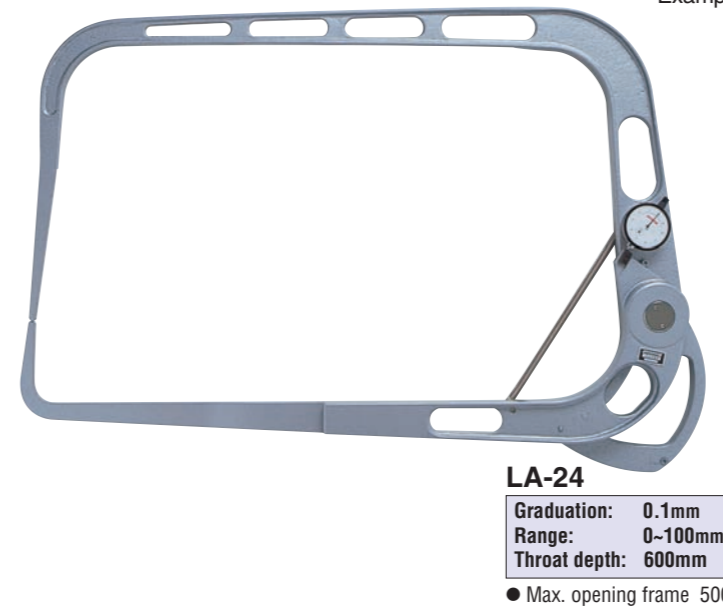

LA-24
Graduation: 0.1mm
Range: 0~100mm
Throat depth: 600mm
● Max. opening frame 500mm

Note: Throat Depth is changed by Measuring Range.
Contact us more detailed information.

Ex. LA-13

Range	Throat Depth
0~ 50mm	235mm
0~ 60mm	125mm
0~ 80mm	102mm
0~100mm	91mm
0~130mm	86mm

Specifications

Model	Graduation (mm)	Range (mm)	Indication error (mm)	Throat depth (mm)	Dimensions (mm)			
					H1	H2	H3	H4
LA-11	0.1	0~50	±0.2	125	2	5.5	2	5.5
LA-13	0.1	0~130	±0.3	235	134	134	15	37
LA-14	0.01	100~150	±0.03	70	—	—	—	—
LA-20	0.1	0~80	±0.2	125	17	11	17	11
LA-21	0.1	0~80	±0.2	220	66	69	12	10
LA-22	0.1	0~80	±0.2	250	28	23	62	62
LA-23	0.1	0~80	±0.2	300	45	50	48	43
LA-24	0.1	0~100	±0.4	600	300	300	100	100
LA-31	0.01	0~20	±0.03	125	60	63	—	—

see page 100



LB series (Inside measuring of ID and groove widths)

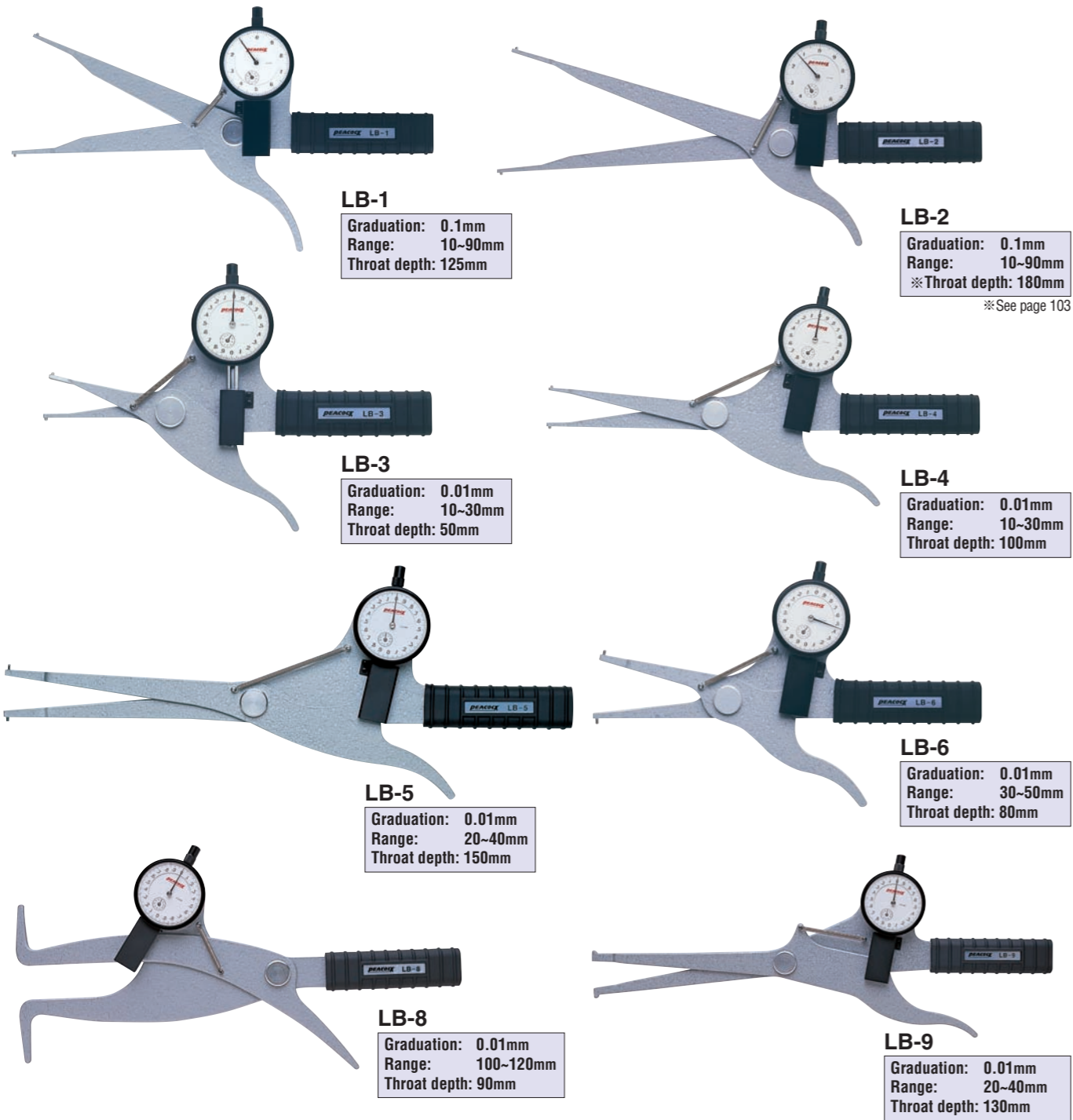

Dimensions for contact point

(LB-1 · 2 · 3 · 4 · 5 · 6 · 7 · LH-2)

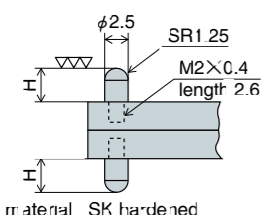

※ Hmm (height of contact point)
3, 4, 5, 6, 7, 8, 9, 10mm type are available as options. Order pair as 1 set (2pcs).

(LB-7V)

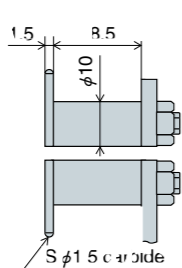

(LB-7S)

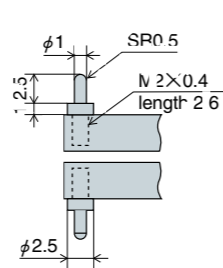

(LA-14 · LB-14)

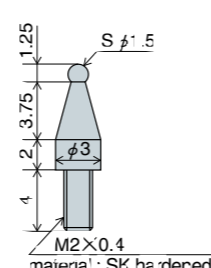

Adjustable type

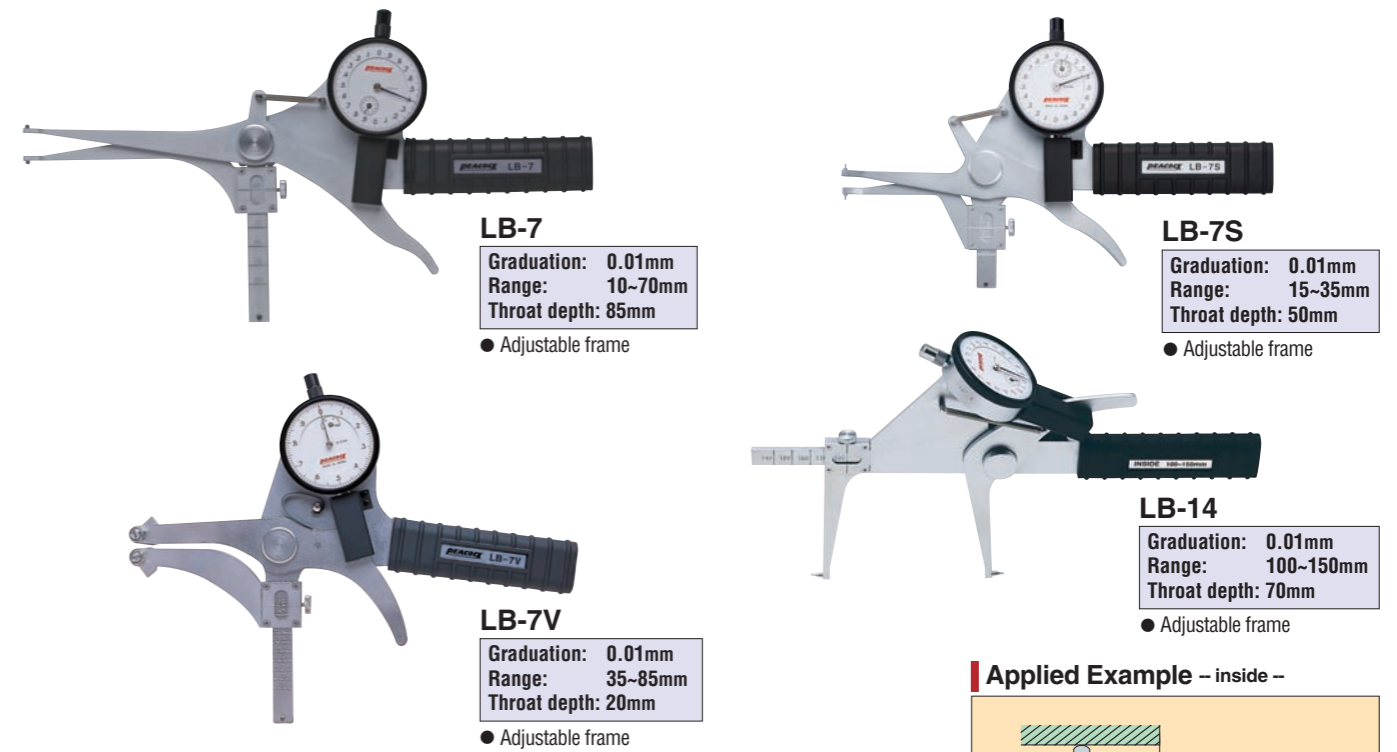

Applied Example - inside -

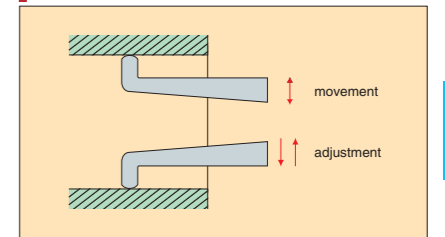

Note: Throat Depth is changed by Measuring Range.
Contact us more detailed information.

Ex. LB-2

Range	Throat Depth
10mm	up to 20mm
15mm	up to 45mm
20mm	up to 70mm
30mm	up to 84mm
90mm	up to 180mm

Handy type



Specifications

Model	Graduation (mm)	Range (mm)	Indication error (mm)	Throat depth (mm)	Height of contact point (mm)
LB-1	0.1	10~90	±0.2	125	2
LB-2	0.1	10~90	±0.2	180	2
LB-3	0.01	10~30	±0.03	50	2
LB-4	0.01	10~30	±0.03	100	2
LB-5	0.01	20~40	±0.03	150	4
LB-6	0.01	30~50	±0.03	80	4
LB-7	0.01	10~70	±0.03	85	2
LB-7S	0.01	15~35	±0.03	50	3.5
LB-7V	0.01	35~85	±0.03	20	6.5
LB-8	0.01	100~120	±0.03	90	30 (SK hardened, one unit with frame)
LB-9	0.01	20~40	±0.03	130	2 (SK hardened, one unit with frame)
LB-14	0.01	100~150	±0.03	70	7
※ LH-2	0.01	10~120	±0.03	50	2

※ For LH-2, the range of accuracy is 10 to 20mm. In case of 20mm or more, check the tolerance with Master Gauge.



"PEACOCK" Caliper Gauges are quite useful for such measurements of O.D. or I.D. thickness and diameter which appear so difficult to measure.

Examples

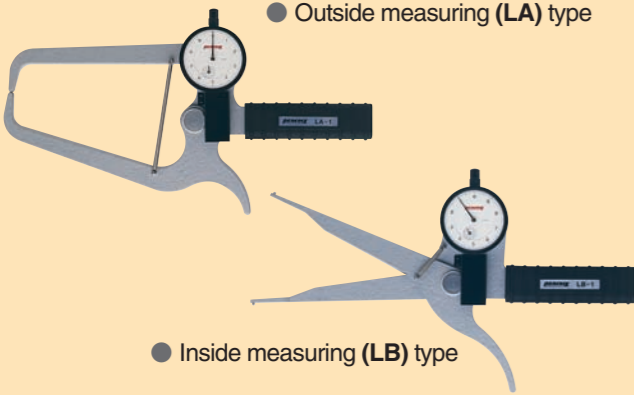
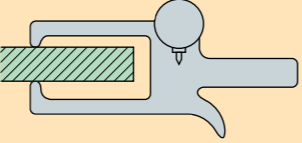
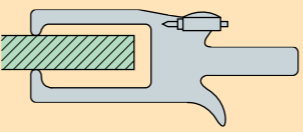
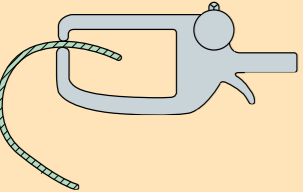
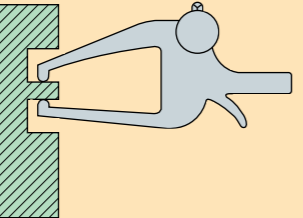
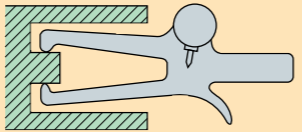
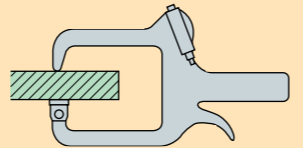
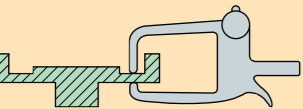
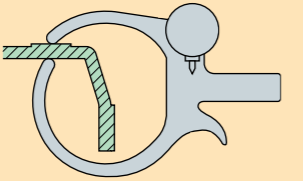
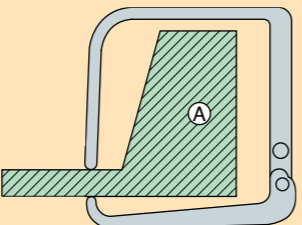
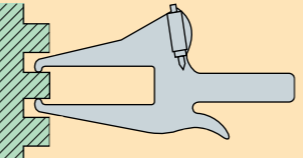
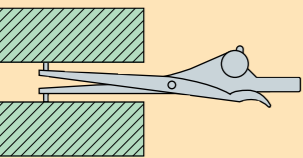
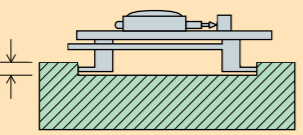
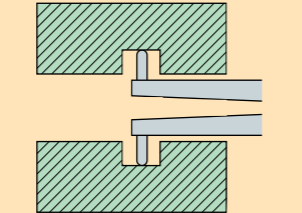
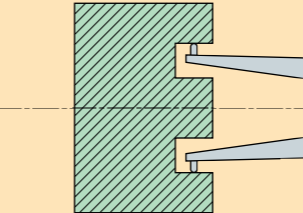
 <p>● Outside measuring (LA) type</p> <p>● Inside measuring (LB) type</p>	 <p>● Measuring thickness at the back end of a projecting workpiece LA-1~4 LA-13 LA-20~23</p>	 <p>● Measuring thickness at the back end of a projecting workpiece ● Dial upward type LA-5 LA-5S</p>	
 <p>● Measuring thickness of a cup, hat or helmet LA type</p>	 <p>● Measuring thickness or OD in a narrow, confined place LA type</p>	 <p>● Measuring center OD of a boss LA-11</p>	 <p>● Floating type: lower contact point has a flat 10mm diameter LA-10</p>
 <p>● Measuring thickness by hurdling a projecting area LA type</p>	 <p>● Measuring thickness by hurdling a projecting area LA-8</p>	 <p>● Measuring thickness of a large workpiece or part. A: workpiece sizes up to 500mm are accessible (LA-24).</p>	 <p>● Measuring thickness or OD in a narrow, confined place LA-9 LA-11</p>
 <p>● Measuring ID or groove width LB-1~6</p>	 <p>● Measuring ID of a very shallow hole A: approximately 2mm lip is sufficient (LB-7V)</p>	 <p>● Measuring ID or an O-ring groove LB-1~6</p>	 <p>● Measuring ID by straddling the center boss LB-7 LB-14</p>

SECTION

8



Applied Dial Gauges

- Dial Depth Gauges
- Digital Depth Gauges
- Dial Inside Gauges
- Dial Hole Gauge
- Digital Hole Gauge
- Applied Contact Points
- Bench Center

Dial Depth Gauges

It measure a depth from top bottom of bottomed holes, a depth of narrow grooves, a value of step height of stepped surfaces and a depth of types engraved in matrices.
The dial gauge furnished offers a correct measured value since it can measure an object under measurement with a given measuring force.

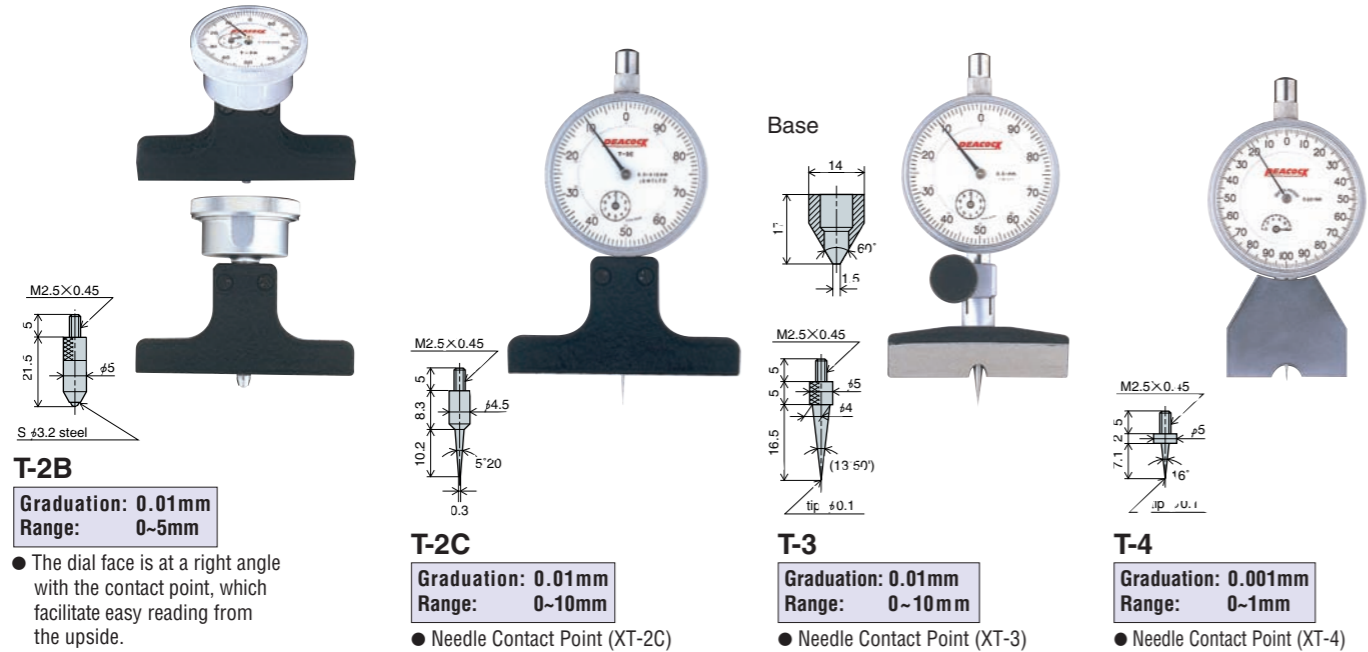
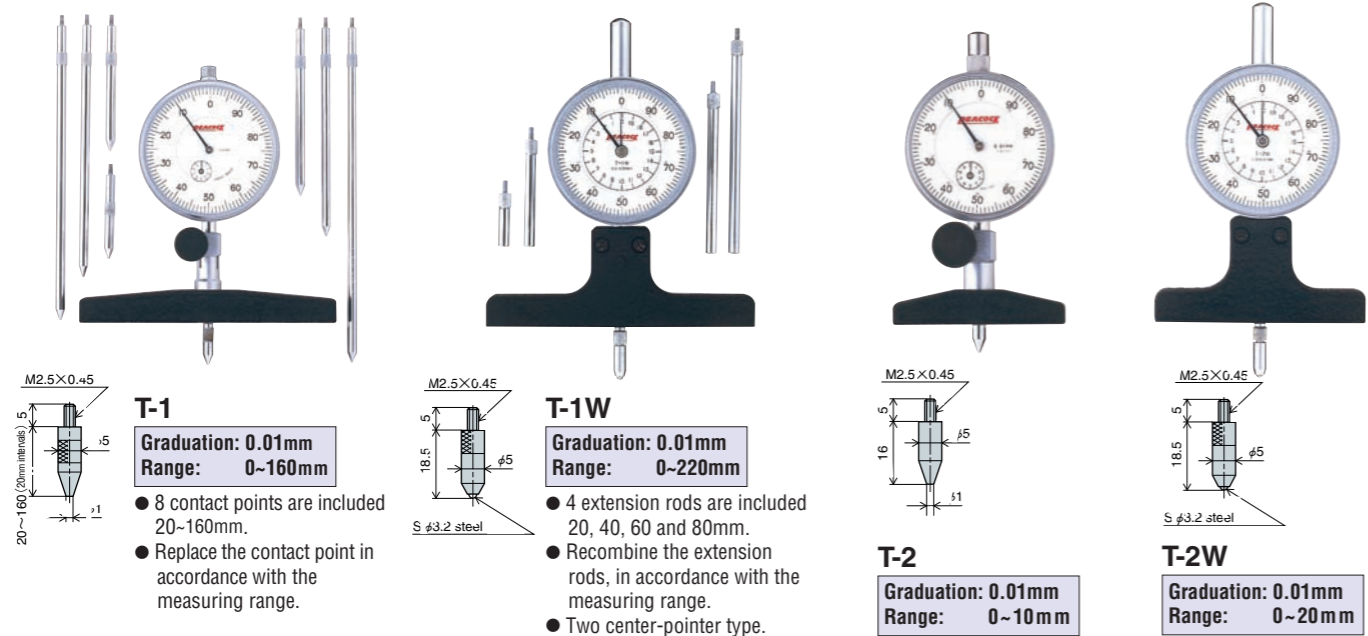

Specifications

Model	Range (mm)	Accuracy (μm)	Dial Gauge				Base	
			Gauge installed	Graduation (mm)	Range (mm)	Measuring force less than (N)	Length (mm)	Width (mm)
T-1	0~160	±20	207F-T	0.01	20	2.0	120	14
T-1W	0~220	±20	207WF-T	0.01	20	2.0	100	11
T-2	0~10	±15	107F-T	0.01	10	1.4	60	14
T-2W	0~20	±20	207WF-T	0.01	20	2.0	75	11
T-2B	0~5	±20	196B-T	0.01	5	1.4	75	11
T-2C	0~10	±15	107F-T	0.01	10	1.4	75	11
T-3	0~10	±15	107F-T	0.01	10	1.4	60	Shown in above figure
T-4	0~1	±5	※5F	0.001	1	1.5	40	10

※ 5F with Reversed Inner Dial

※ Base is hardened and polished.

Dial Depth Gauge

Round Base type

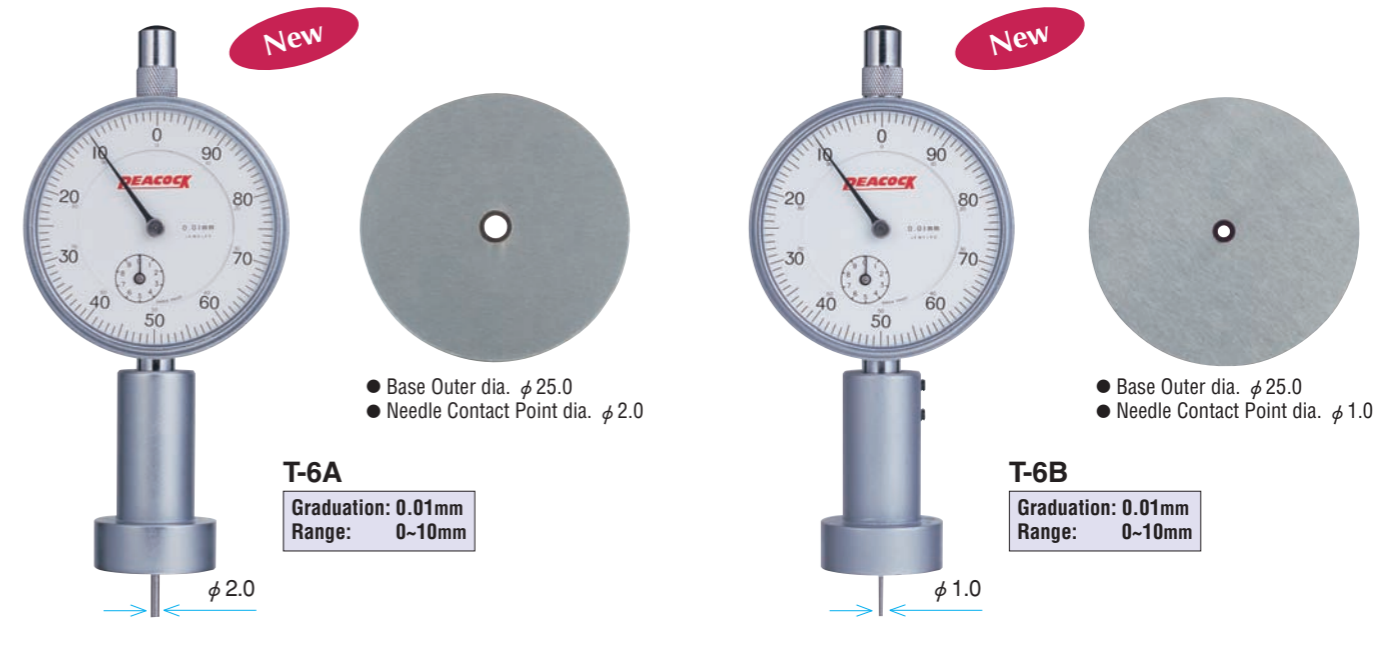

Specifications

Model	Range (mm)	Accuracy (μm)	Dial Gauge				Base	
			Gauge installed	Graduation (mm)	Range (mm)	Measuring force less than (N)	Length (mm)	Width (mm)
T-6A	0~10	±15	107F-T	0.01	10	1.4	—	—
T-6B	0~10	±15	107F-T	0.01	10	1.4	—	—

Dimensions (※) are T-6B)

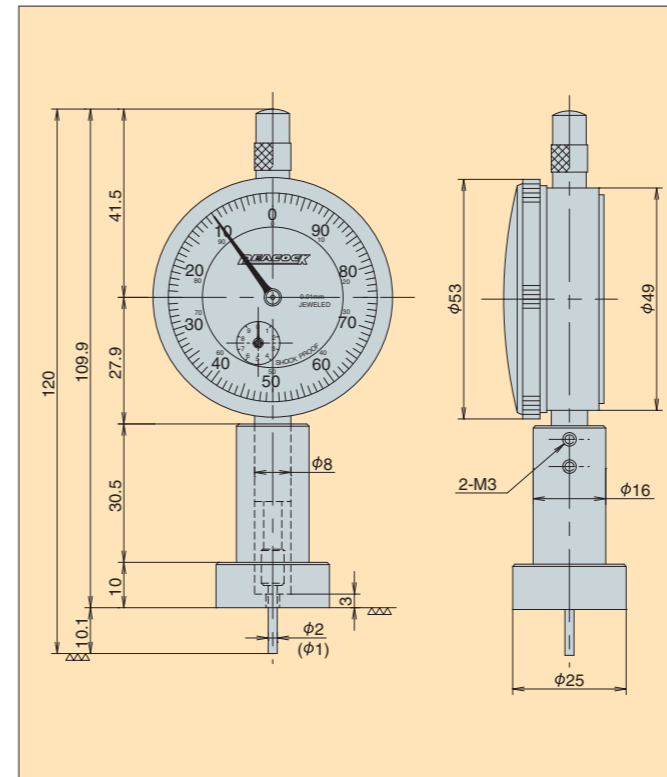

Custom order available

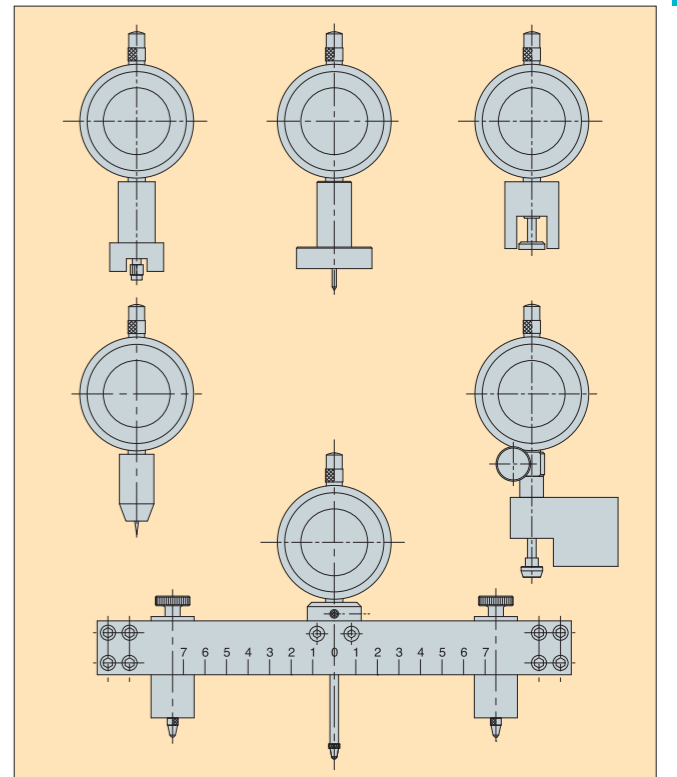

Digital Depth Gauges

Dimensions for Digital Depth Gauges



T1-205
Graduation: 0.001mm
Range: 20mm



T2-127
Graduation: 0.01mm
Range: 10mm



T2-205W
Graduation: 0.001mm
Range: 20mm

T1-257
Graduation: 0.01mm
Range: 20mm

T2-257W
Graduation: 0.01mm
Range: 20mm

● Contact Point (XS-315)



T3-127
Graduation: 0.01mm
Range: 10mm
● Contact Point (XT-3)



T5-127
Graduation: 0.01mm
Range: 10mm
● Contact Point (XT-4)



T6-127
Graduation: 0.01mm
Range: 10mm

Specifications

Model	Graduation (mm)	Accuracy (mm) (excluding quantized error)	Gauge installed	Range (mm)	Base flatness (mm)	Option
T1-205	0.001	±0.004	DG-205	20	0.005	7 contact points 40-160mm (20mm intervals)
T1-257	0.01	±0.02	DG-257	20	0.005	
T1-127	0.01	±0.02	DG-127	10	0.005	—
T2-205W	0.001	±0.004	DG-205	20	0.005	—
T2-257W	0.01	±0.02	DG-257	20	0.005	—
T3-127	0.01	±0.02	DG-127	10	0.005	—
T5-127	0.01	±0.02	DG-127	10	0.005	—
T6-127	0.01	±0.02	DG-127	10	0.005	—

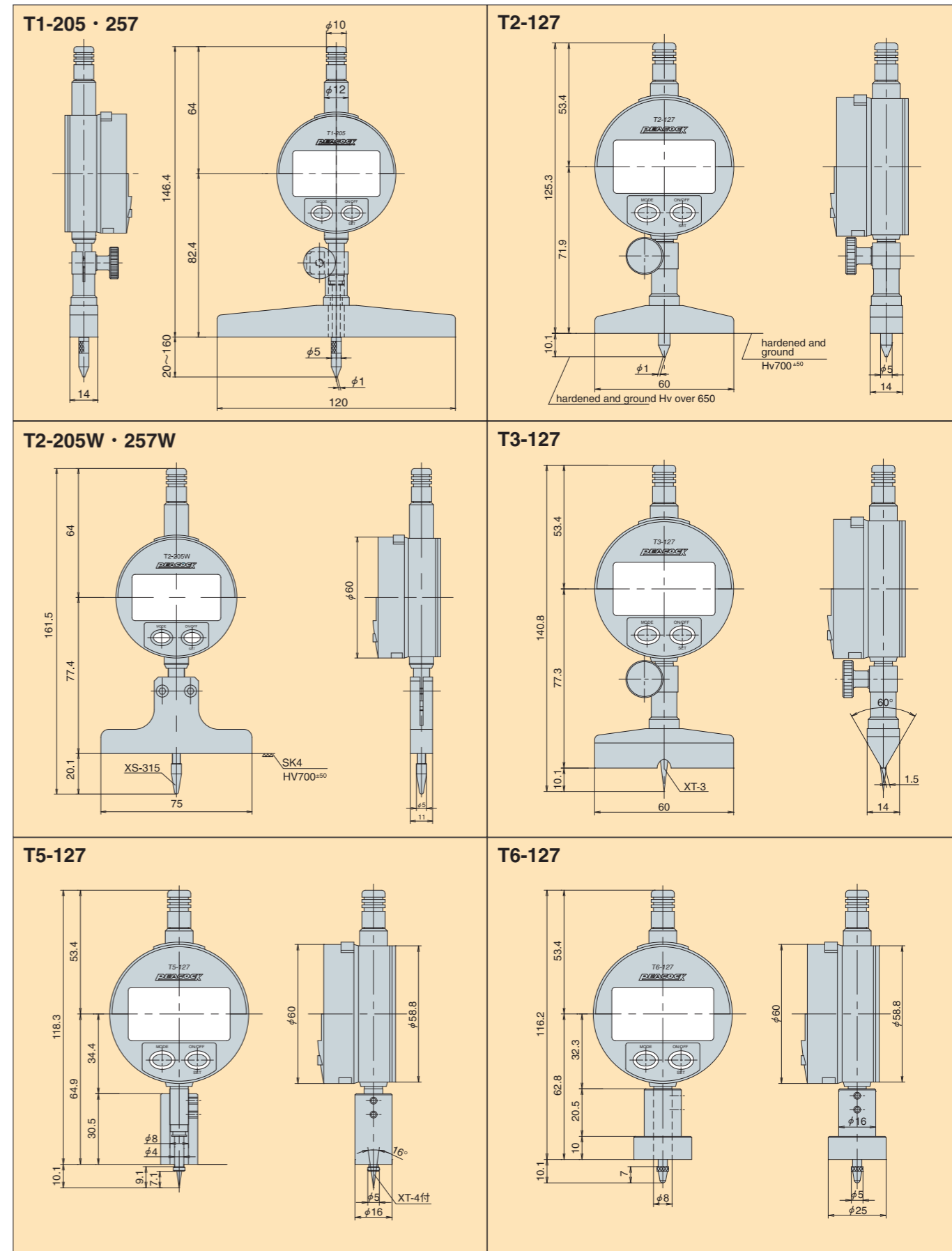

Dial Inside Gauge

- Capable of continuously measuring comparatively large bores or inside wall surface with a given measuring force using flexibility of the dial gauge.

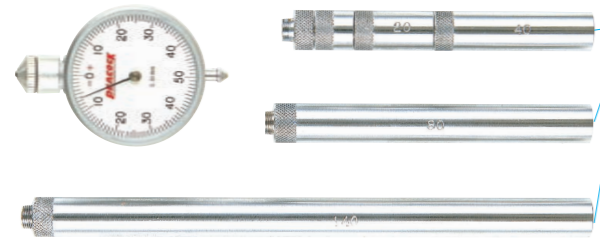

Extension rods 6pcs.
(5, 10, 20, 40, 80, 140mm)
Replace the extension rods
according to a measuring
range.

U-1

Graduation: 0.01mm
Range: 50~350mm
(Measuring range of dial gauge: 5mm)

Outer dimension

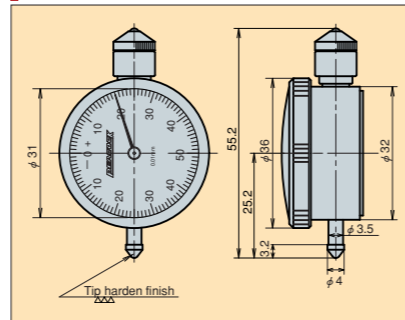

With Magnetic Base

The gauge proper can be secured to the measuring position by the magnet base.



U2HA

Graduation: 0.01mm
Range: 66~80mm
(Measuring range of dial gauge: 4mm)



U2HB

Graduation: 0.01mm
Range: 80~92mm
(Measuring range of dial gauge: 4mm)

U2FA

Graduation: 0.01mm
Range: 92~110mm
(Measuring range of dial gauge: 5mm)

U2FB

Graduation: 0.01mm
Range: 110~120mm
(Measuring range of dial gauge: 5mm)



U3HA

Graduation: 0.01mm
Range: 66~80mm
(Measuring range of dial gauge: 4mm)

with shorter pointer



U3HB

Graduation: 0.01mm
Range: 80~92mm
(Measuring range of dial gauge: 4mm)

with shorter pointer

Dimensions (※ () are U2FA·U2FB)

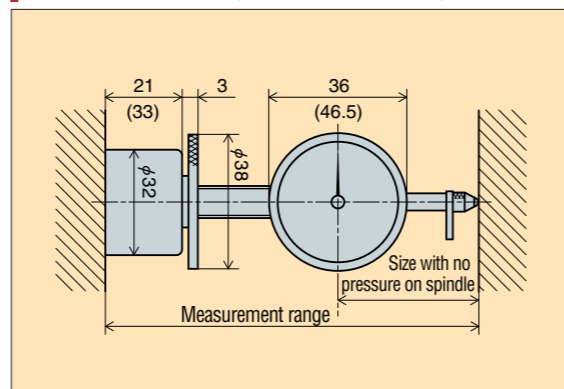

Specifications

Model	Graduation (mm)	Range (mm)	Reading	Indication error (unit: μm)					Magnetic Power (kg)	Measuring force less than (N)
				1/10 revolution (Adjacent error)	1/2 revolution	1 revolution	2 revolutions	Whole measuring range		
U-1	0.01	50~350	0 - 50 - 0	9	—	±13	—	±20	—	2.0
U2HA	0.01	66~80	0 - 50 - 0	9	—	±13	—	±15	8~10kg	1.4
U2HB	0.01	80~92	0 - 50 - 0	9	—	±13	—	±15		1.4
U2FA	0.01	92~110	0 - 50 - 0	9	—	±13	—	±20		2.0
U2FB	0.01	110~120	0 - 50 - 0	9	—	±13	—	±20		2.0
U3HA	0.01	66~80	0 - 50 - 0	9	—	±13	—	±20		1.4
U3HB	0.01	80~92	0 - 50 - 0	9	—	±13	—	±20		1.4

Dial Hole Gauge

The Dial Hole Gauge is used for measurement of a bore diameter or groove width.

- Adjustable upper frame may be changed as desired, thus securing a wide measuring range.
- The contact point has an outer dia of 2 mm and a height of 2 mm. (R 1mm ball, M1.7 x 0.35mm.)



GH-1

Graduation: 0.01mm
Range: 10 mm

Specifications

Model	Dial Gauge					Measurable bore ID (mm)	Measurable depth less than (mm)
	Graduation (mm)	Range (mm)	Accuracy(μm)	Reading	Measuring force less than (N)		
GH-1	0.01	10	±20	±100-50-0	1.4	10~50	25

Digital Hole Gauge



GH-127

Graduation: 0.01mm
Range: 10~35 mm

Dimensions

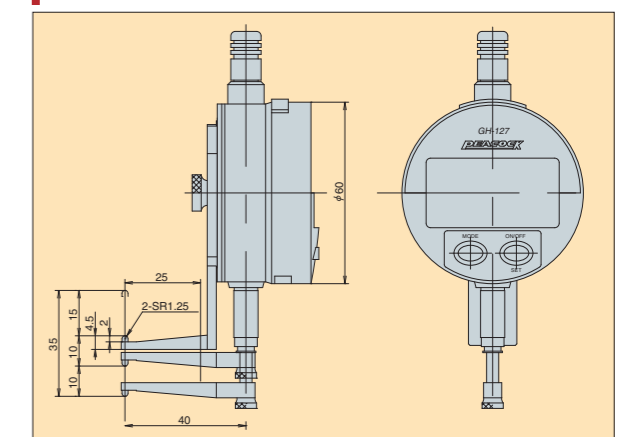

Specifications

Model	Graduation (mm)	Accuracy (excluding quantized error)	Gauge installed	Range (mm)	Measurable bore ID (mm)	Measuring force	Measurable depth less than (mm)
GH-127	0.01	±0.02	DG-127	10-35	10-35	Less than 0.95N	25

Applied Contact Points

Lever type Contact Points

Dial Gauges supplied on request (Recommend a Dial Gauge with Lug Back and install it to a Magnet Stand.)

- This instrument have a 50mm length of lever and used to measure depth of holes. The flat contact point (XS-2) is installed to the dial gauge to hold the back when used.

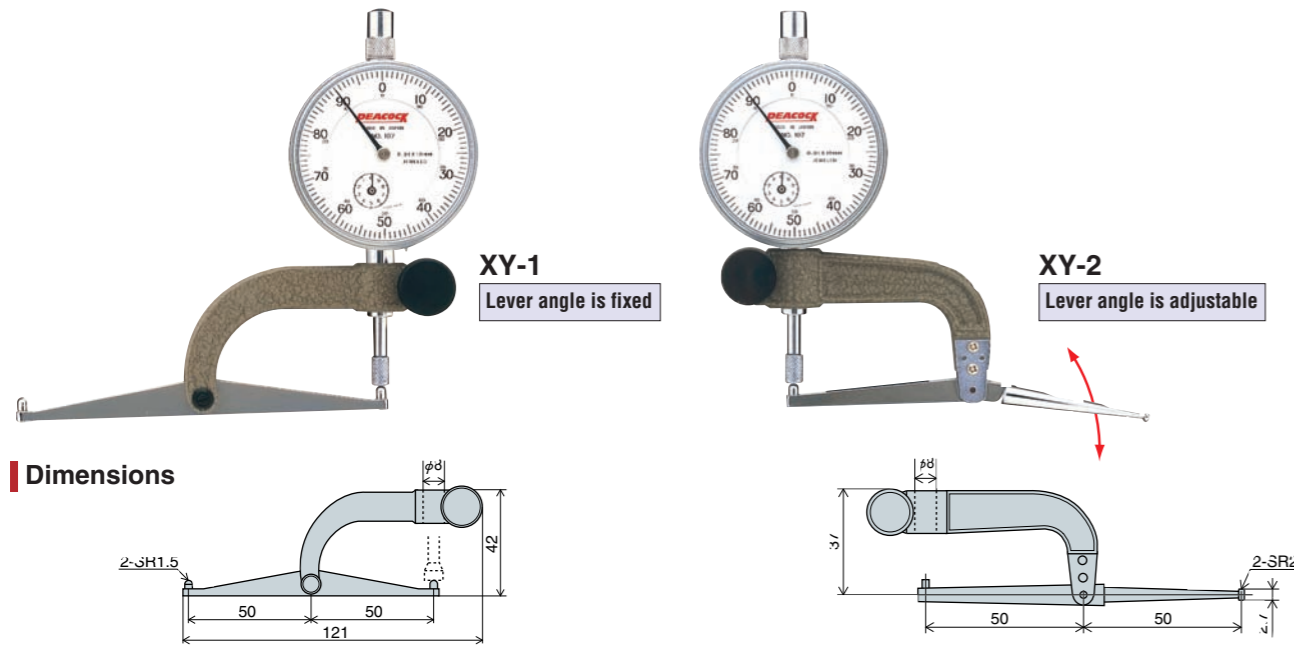

Angle Contact Points

Dial Gauges supplied on request (Recommend a Dial Gauge with Flat Back due to light weight.)

- The contact point is tilted in its moving direction by the cam, and it includes two types; tilted to 45° and 60°. The contact point is convenient for measurement on locations where it is impossible to straightforwardly install the dial gauge and to use it for a jig. Hold the ϕ 8 stem when used.

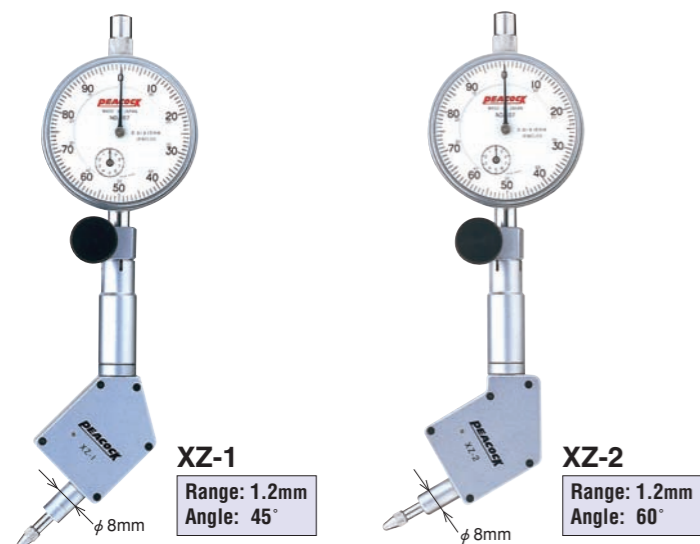

Exterior dimensions

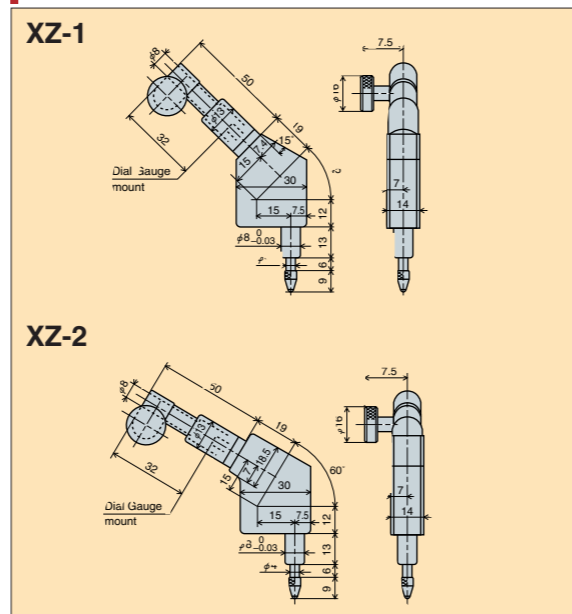

Specifications

Model	Angle	Range (mm)	Moving distance (mm)	Measuring force less than (N)
XZ-1	45°	1.2	5	1.4
XZ-2	60°	1.2	5	1.4

● Angle 90° is available on request.

Bench Center

High-accuracy eccentricity tester used to measure eccentricity of articles over a wide range of rotary cutting tools, arbors, crankshafts, gears, piston heads or grinding stones and to check circles for roundness. (dial gauges are not furnished)

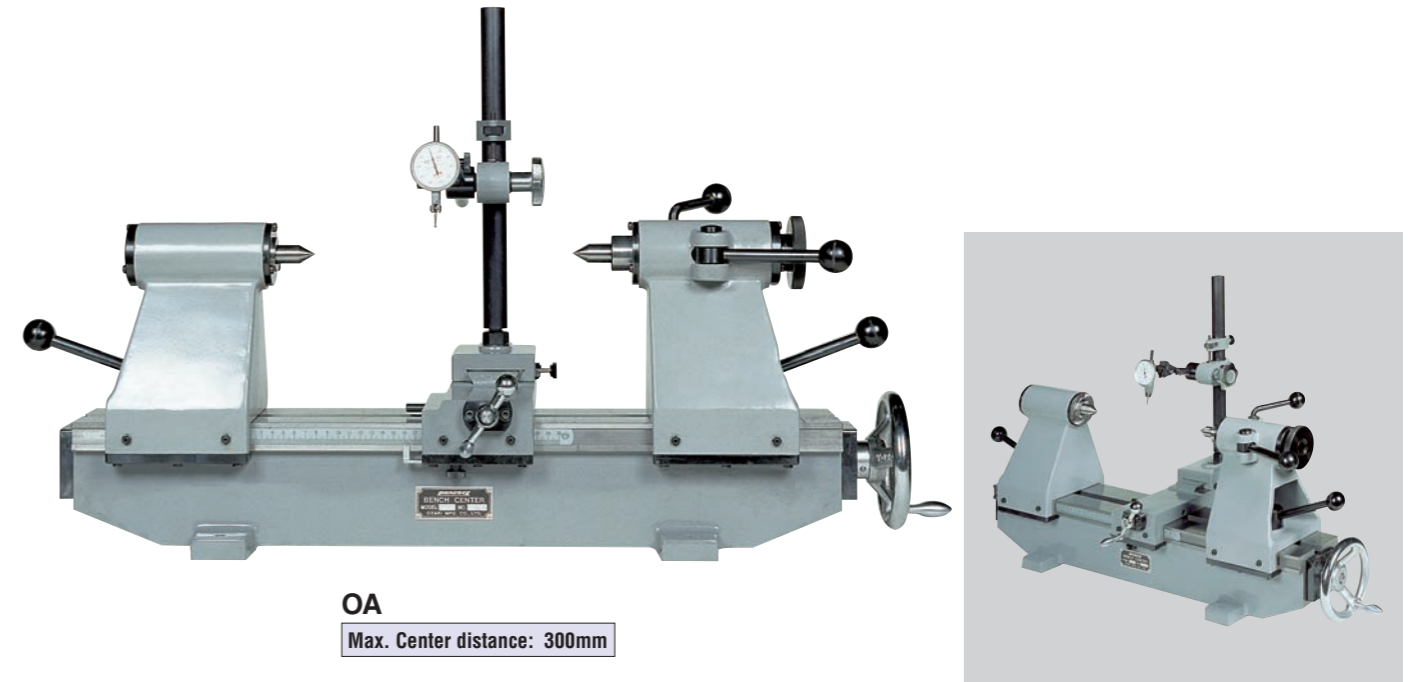

Dimensions (OA)

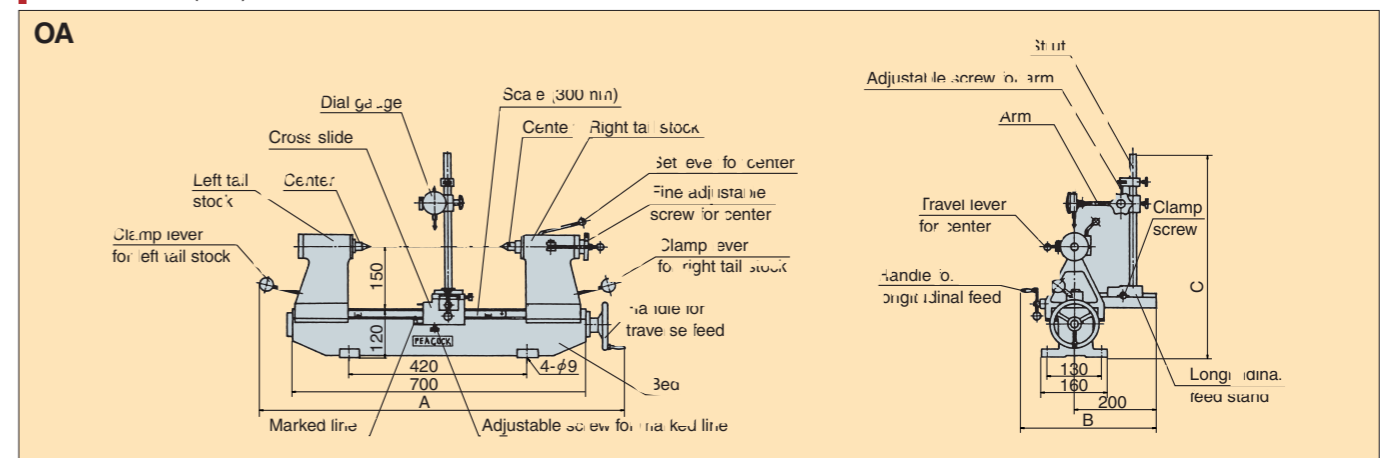

Specifications

Model	Center distance (mm)	Max. work capacity dia. (mm)	Use center	Overall dimensions			Approx. weight (kg)	Feed gear	
				(A) mm	(B) mm	(C) mm		Right and left	Back and forth
OA	300	230	MT No. 2	Approx. 875	Approx. 335	500	51	Screw feed	Screw feed

OVER LOAD GAUGE for TIRE CURING MACHINE

For passenger vehicle tires and those for truck and bus tires
(Made to order)

We, "PEACOCK" make OVER LOAD GAUGES for TIRE CURING MACHINES that applied our Dial Gauge.

Example pictures of Over Load Gauge for TIRE CURING MACHINE

0-300TON
with Back Plate & Dust Proof Rubber
(Spec. Pointer 1 rotation: 0.5mm)



0-1000TON
with Dust Proof Rubber
(Spec. Pointer 1 rotation: 0.5mm)



1. For making the Dial Plate, please let us know the angle for range of graduation to meet with the Tightening force (TON).
*see diagram as under. Example Spec. Pointer 1 rotation: 1mm

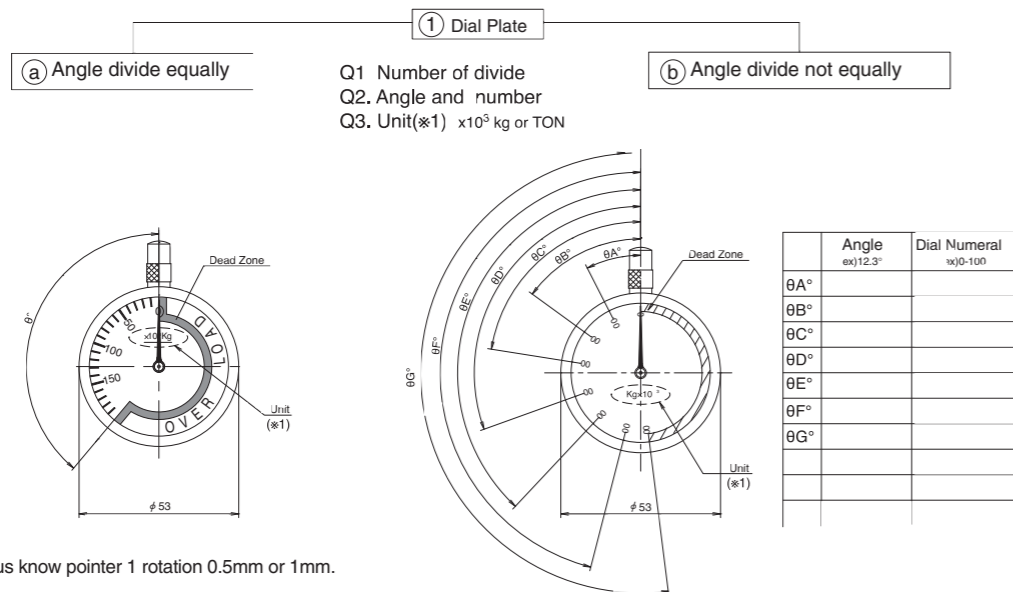

2. We provide the Over Load Gauge with Back Plate to meet with your Tire Curing Machine.

Dust Proof Rubber can be installed to the Spindle of Over Load Gauge.

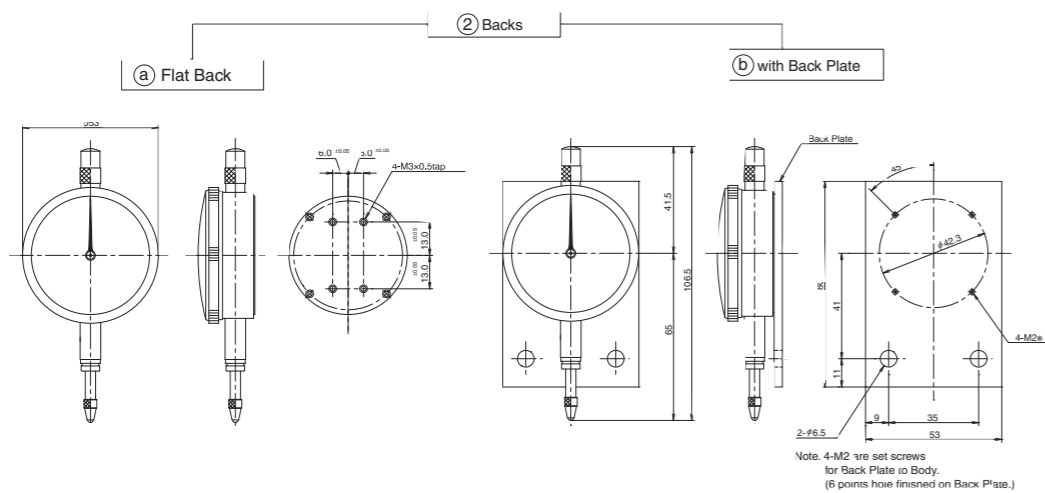

Please contact your local "PEACOCK" distributor for your further inquiry or write to us at:

peacock-tokyo@peacockzaki.jp

SECTION

9



Stands

- Dial Gauge Stands
- Magnetic Stands
- Magnetic Holder

Dial Gauge Stands

Renewed

Stand designed for precision measurement of standard dial gauges, lever dial gauges and lever electric micrometers, rigid in construction and easy in fine adjustment of gauge indication by the original fine adjusting device.

SIS-4F

- With fine adjustment
(Dial Gauge and Pic Test Indicator are not furnished.)



Mounting example for Dial Gauge
(ϕ 8mm Stem)

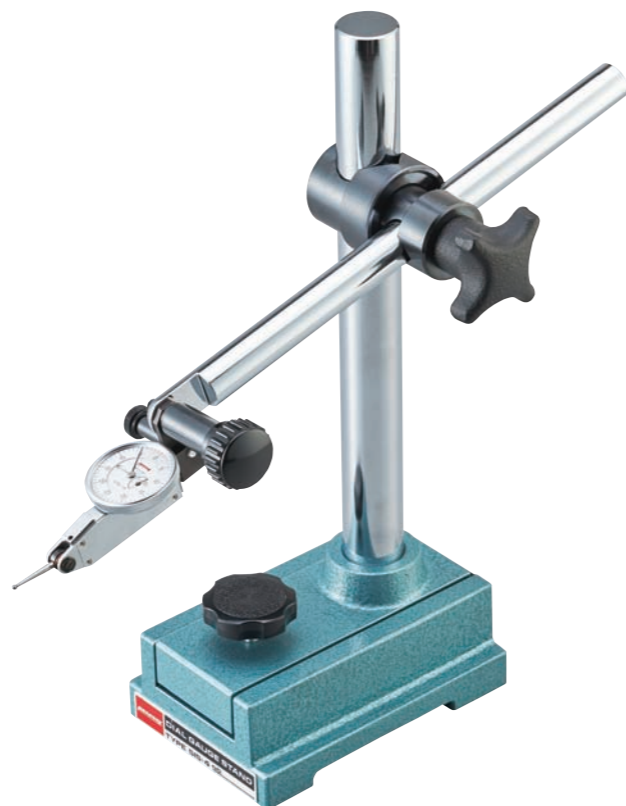

Mounting example for Pic Test Indicator
(ϕ 6mm Stem)

Dimensions

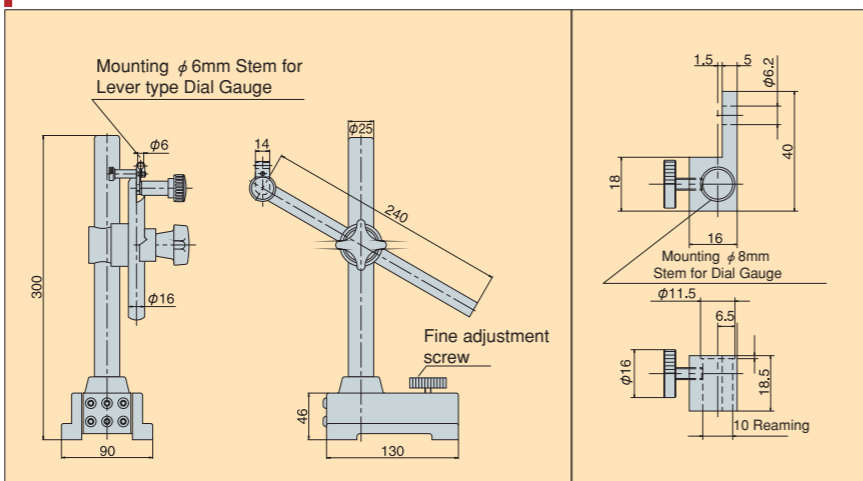

Attachment (For Mounting a Dial Gauge)

Specifications

Model	Base			Main column		Support column		Weight (kg)	Included attachments
	Height (mm)	Length (mm)	Width (mm)	Diameter (mm)	Length (mm)	Diameter (mm)	Length (mm)		
SIS-4F	46	130	90	25	250	16	240	5.2	1. for Dial Gauges 2. for Lever type Dial Indicators

Economy-wise popular stand



SIS-6C

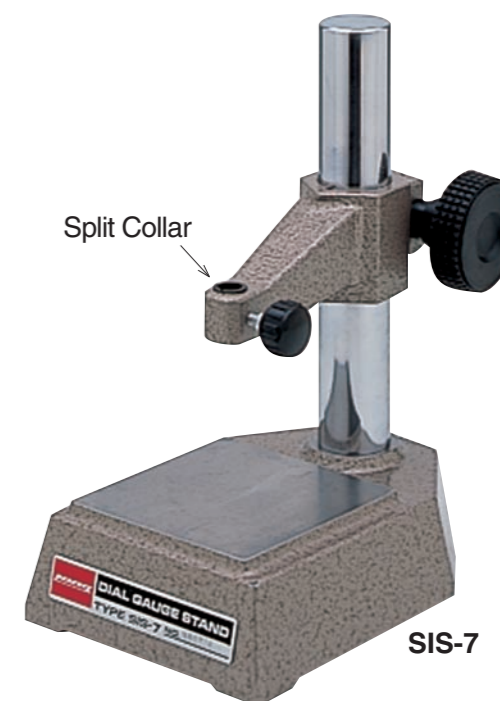

SIS-7

Specifications

Model	Table surface	Table size	Effective moving range	Allowable measuring depth	Stem installed
SIS-6C	Quench-hardened and polished	50mm diameter	0 to about 100 mm	Approximately 62.5mm	ϕ 8mm (** ϕ 10mm)
SIS-7	Ground cast iron surface	74×74mm	0 to about 100 mm	Approximately 52mm	

** ϕ 10mm can be installed when split collar is removed.

The stand is designed for standard dial gauges and digital linear gauges and is rigid and easy to work.

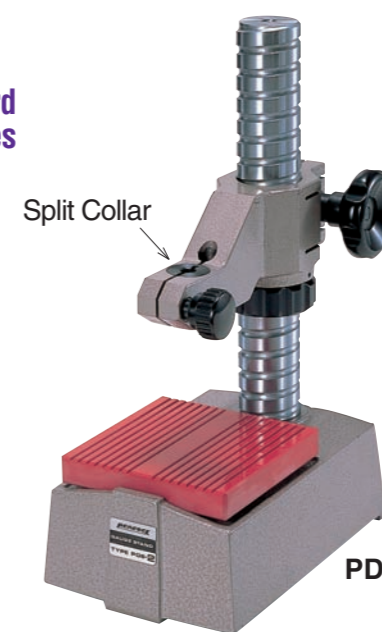

PDS-2



PDS-2F

Specifications

Model	Table surface	Table size	Effective moving range	Allowable measuring depth	Stem installed
PDS-2	Ceramic with grooves	100×100mm	0 to about 100 mm	Approximately 60mm	ϕ 8mm (** ϕ 20mm)
PDS-2F	Ceramic without grooves	100×100mm	0 to about 100 mm	Approximately 60mm	

** ϕ 20mm can be installed when split collar is removed.



Magnetic Stands

The stand using a powerful magnet features simple and stable holding at any place, easy handling, compactness and reasonable price. Either lever dial gauge (held by $\phi 6$ mm stem) or standard dial gauge (held by back lug) is attachable to all types of these magnetic stands. The dial gauges are not furnished.

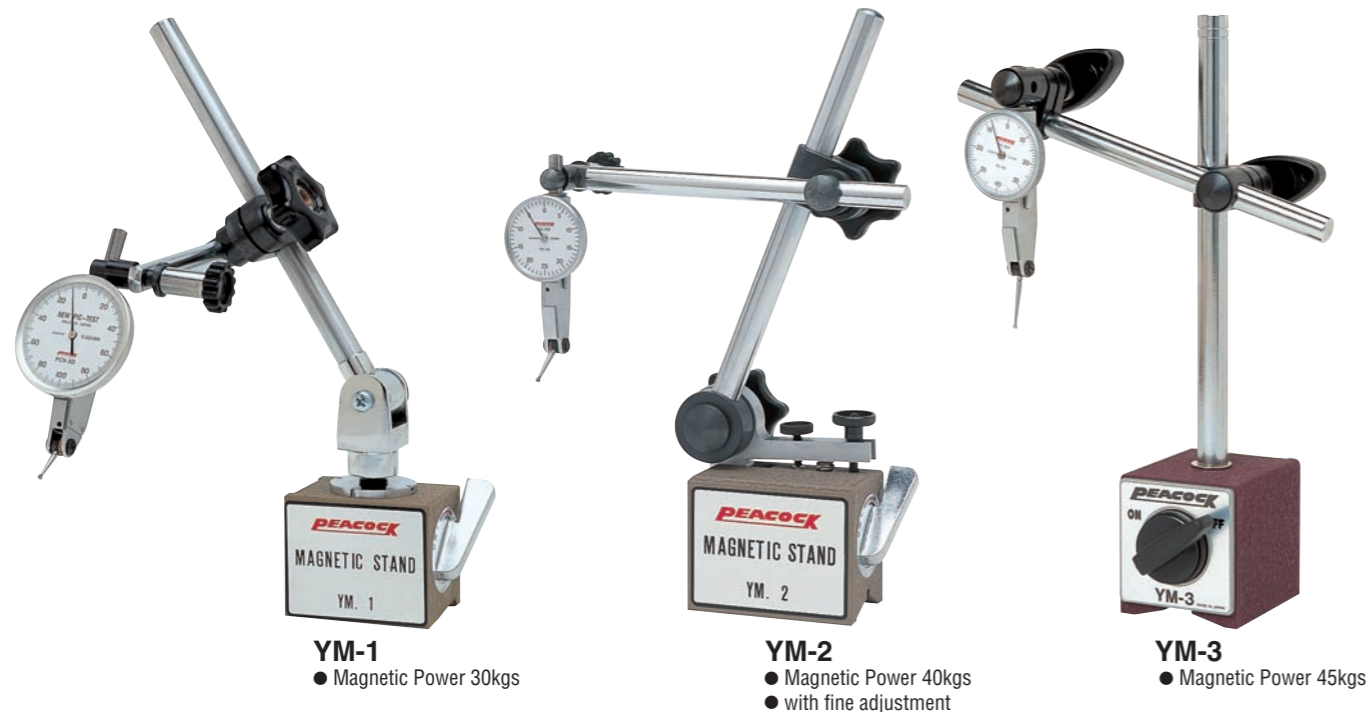

YM-1
● Magnetic Power 30kgs

YM-2
● Magnetic Power 40kgs
● with fine adjustment

YM-3
● Magnetic Power 45kgs

Dimensions

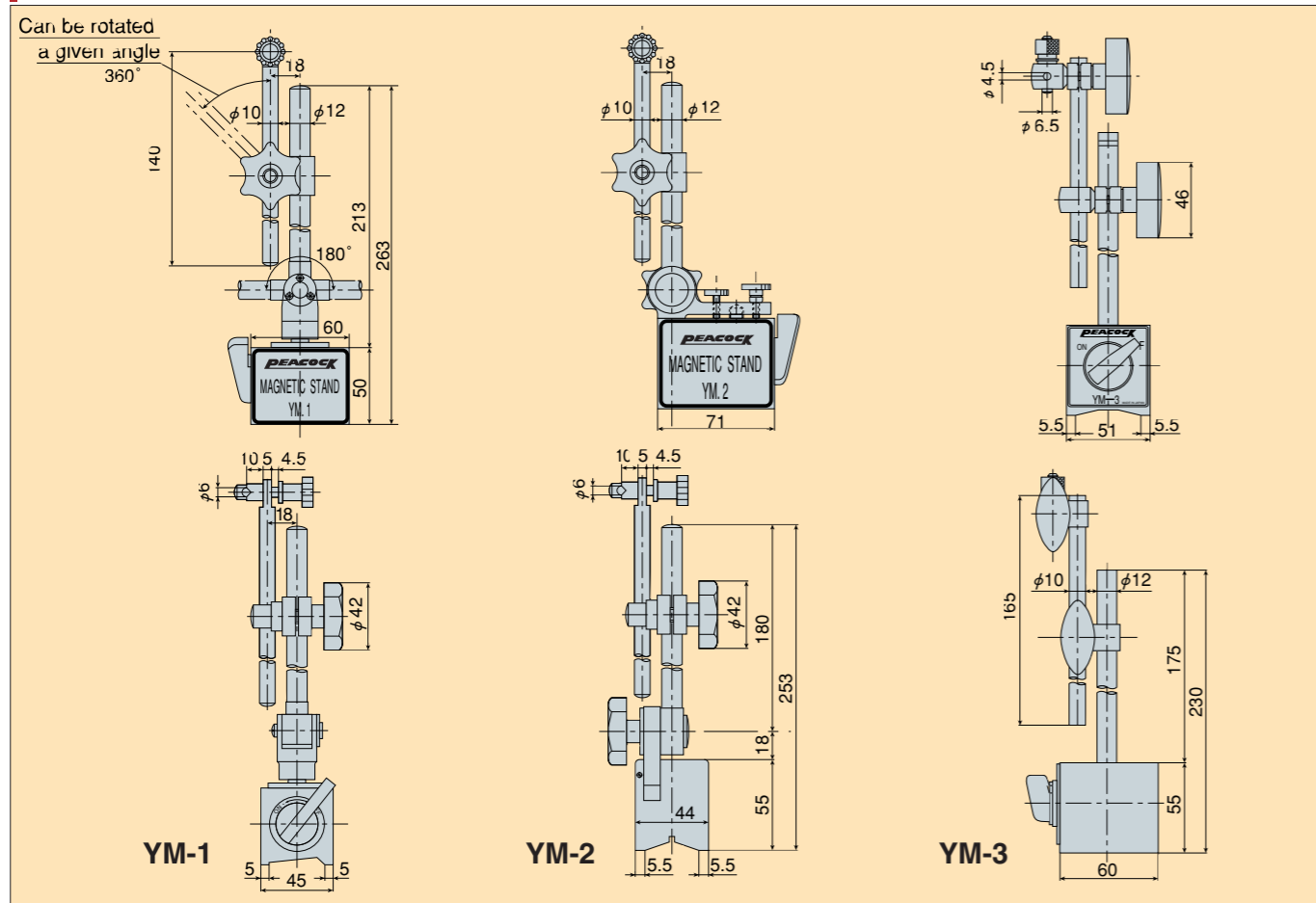

Magnetic Holder

The magnetic holder holds a dial gauge using the attractive force of the magnet fit in the base. It has features of being compact, simple to handle and stable in holding.

- The YMH-1 is for general dial gauges.



YMH-1
(Dial Gauge is not furnished)
● Magnetic Power 10kgs

Examples (YMH-1)

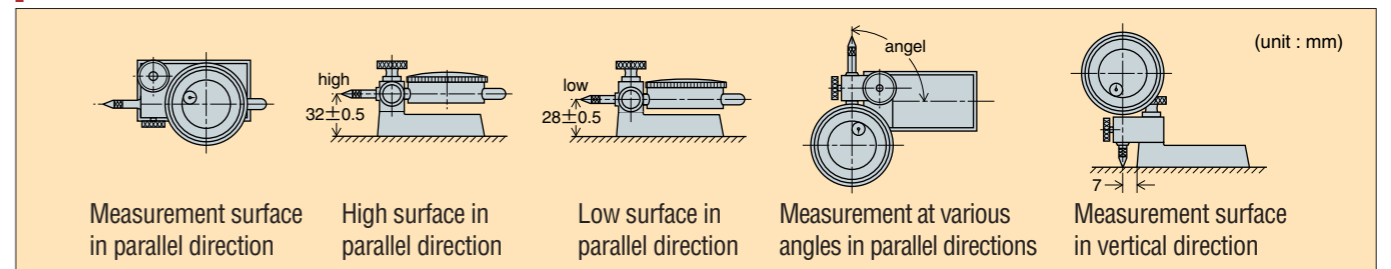

Specifications

Model	Base (mm)			Magnetic power (kgs)	Suitable indicators
	Width	Length	Height		
YMH-1	37	100	18	10	For general dial gauges

MEMO

A series of horizontal dotted lines for writing, consisting of 15 lines spaced evenly down the page.

SECTION

10



Signal Indicators

- Signal Gauges
- Signal Checker
- Signal Box
- Signal Gauge Set-Up
- Signal Gauge Connections Diagram

Signal Gauges/Signal Checker

0.001mm, 0.01mm and 0.05mm Type

S-5

- With its high resolution of 0.001mm scale, it is most suitable for judgement of the values measured on finished parts with high accuracy.



S-5

Graduation: 0.001mm
Measurement range: 0.1(±0.05)mm

S-7

- With its resolution of 0.01mm scale, it is generally used. Its pointer is in an anti-shock structure so as to give stable discriminating signals.



S-7

Graduation: 0.01mm
Measurement range: 1.0(±0.5)mm

S-9

- With its most gross scale of 0.05mm, it is applicable to select grossly worked parts and as cast parts at the low-cost.



S-9

Graduation: 0.05mm
Measurement range: 3.0(±1.5)mm

SC-2A

- Once its tolerance is set, a dial gauge is dismantled before using it so that its endurance is really improved. With its large tolerance setting range of 3mm, it is most suitable for judgement of the measured values in a wide tolerance range.

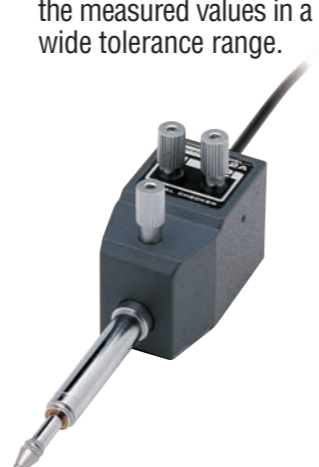

SC-2A

Measurement range: 3mm

Specifications

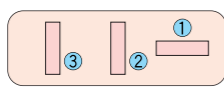
Model	S-5	S-7	S-9	SC-2A
Spindle Movable Range	3mm	3mm	4mm	10mm
Graduation	0.001mm	0.01mm	0.05mm	※ In SC-2A type, the minimum readable value depends on a dial gauge to be attached.
Tolerance Setting Range	0.1 (±0.05) mm	1.0 (±0.5) mm	3.0 (±1.5) mm	3mm
Accuracy	±0.002mm	±0.005mm	±0.025mm	±0.005mm
Measuring Force	Less than 1.2N (120gf)			
Contact capacity	MAX DC24V 20mA			
Number of judgement Stages	Three stages of -NG, OK and +NG			
Cord length	2m			
Contact point	X-2A			
Stem diameter	φ 8 ⁰ _{-0.03} mm			
Operating temperature range	0~60°C			
Options	Code Length 5m 10m / Back cover with Lug (GB-1A)			Code Length 5m 10m
Dial indicator for setting				Model 107F, 5F
Weight	180g			150g
Cable signal table	S-5, S-7, S-9  <ul style="list-style-type: none"> ① ...COM (blue) black -NG with ① and ② at ON ② ...-NG (red) +NG with ① and ③ at ON ③ ...+NG (white) OK with ①, ②, and ③ at OFF 		SC-2A <ul style="list-style-type: none"> ① ...COM (blue) black -NG with ①, ②, and ③ at OFF ② ...OK (red) OK with ① and ② at ON ③ ...+NG (white) +NG with ①, ②, and ③ at ON 	
Caution	<ul style="list-style-type: none"> When the current of 10 to 20 mA is used to drive a photocoupler, etc., the contact may be worn a little earlier. In SC-2A type, the COM terminal is body-grounded (if leak current is found in other devices, put a gauge into floating status before mounting it). In SC-2A type, a spindle can be set in a range from its free status to 3mm. Although it may be movable in excess of this limit, you cannot set it in such an excessive level in order to protect the spindle. In SC-2A type, when a dial gauge is dismantled after setting the tolerance, never forget to mount a dust protective cap. 			

Outer Dimension S-5, S-7 & S-9

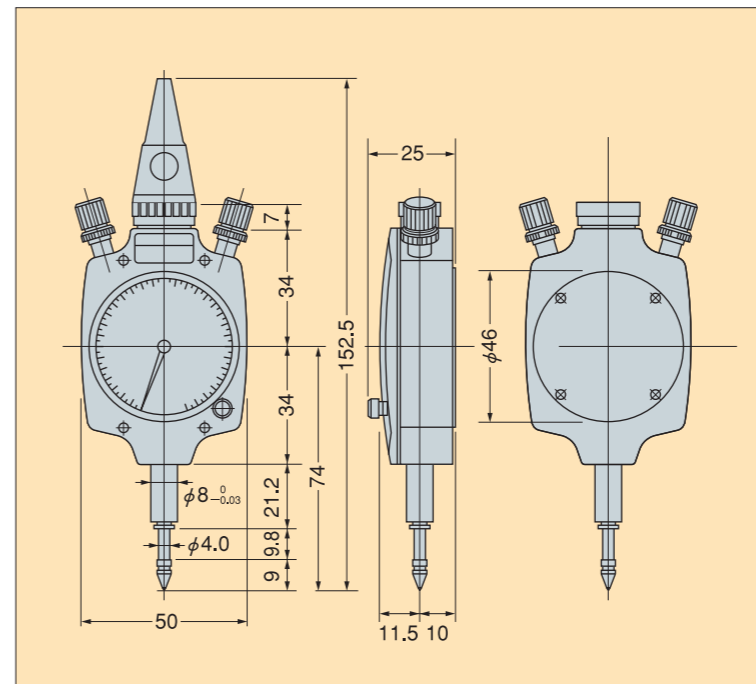

Outer Dimension SC-2A

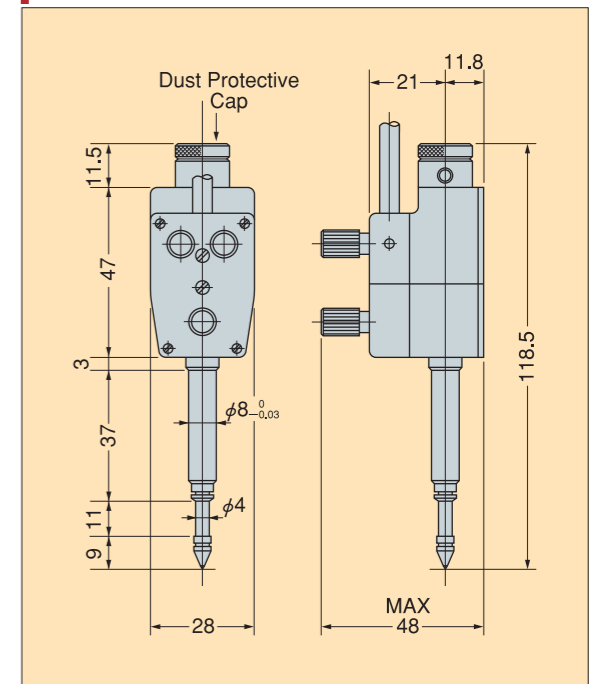

GB-1A Example of mounted back cover with lug (option)

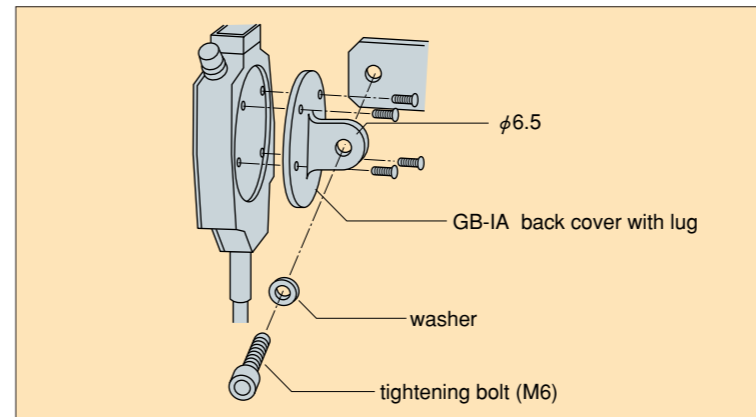

Example of supported stem

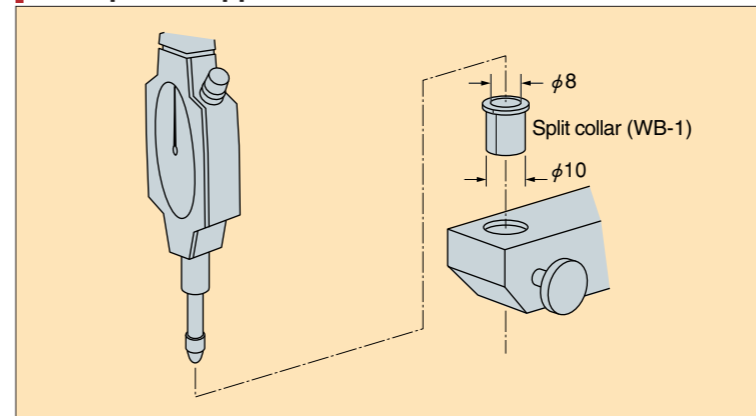

Signal Box

- Long life LED makes a replacement of lamp unnecessary.
- It is equipped with judgement output by relay contact.



SB-3

Specifications

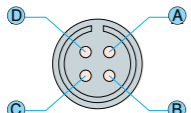
Model	SB-3
Display Colors	-NG (red), OK (green), +NG (yellow)
Relay contact capacity	AC200V (5VA) MAX (resistance load)
Outer Dimensions	(L)150mm×(H)63mm×(D)160mm
Cord length	2m (with plug)
Power supply	AC100V, AC200V 50 / 60Hz
Usable Gauges	S-5, S-7, S-9, SC-2A
Relay contact output	Three stages of -NG, OK, and +NG
Weight	1300g
Output of Relay Contacts	 <ul style="list-style-type: none"> A.....+NG B.....COM C.....OK D.....-NG

Dimensions

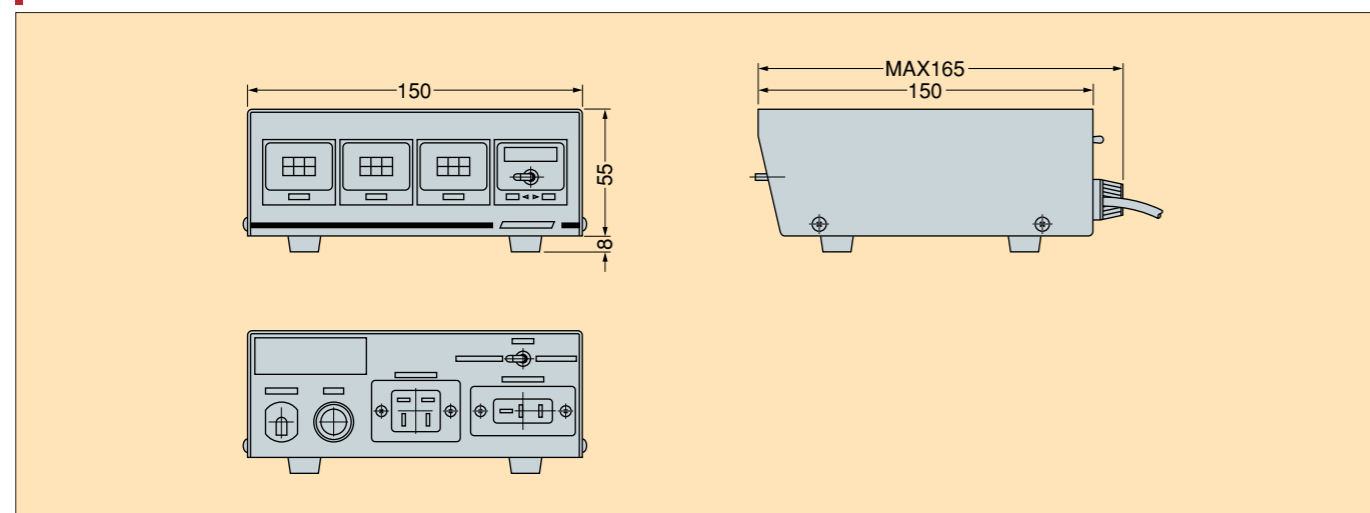

Signal Controller

- This is incorporated in a control panel. All its output and input terminals are connected to the terminal board.
- The large relay contact capacity eliminates previous contact troubles.



SC-2A

Discontinued

Specifications

Model	SC-2A
Lamp display output	AC100V to 18V (max.110mA)
Relay contact capacity	AC200V (5VA) MAX (resistance load)
Outer Dimensions	(L)130mm×(H)88mm×(D)120mm
Setting hole diameter	70mm × 110mm
Power supply	AC100V, AC200V 50 / 60Hz
Usable Gauges	S-5, S-7, S-9, SC-2A
Relay contact output	Three stages of -NG, +NG, and OK
Weight	1300g
Precautions	(1) Disconnect the DC12V line when using the lamp display output to power the relay contact. (Leaving it connected will make for a two-circuit control.) (2) When connecting signal gauges or signal checker, remove the original connector and use crimp-style fork terminals.

Dimensions

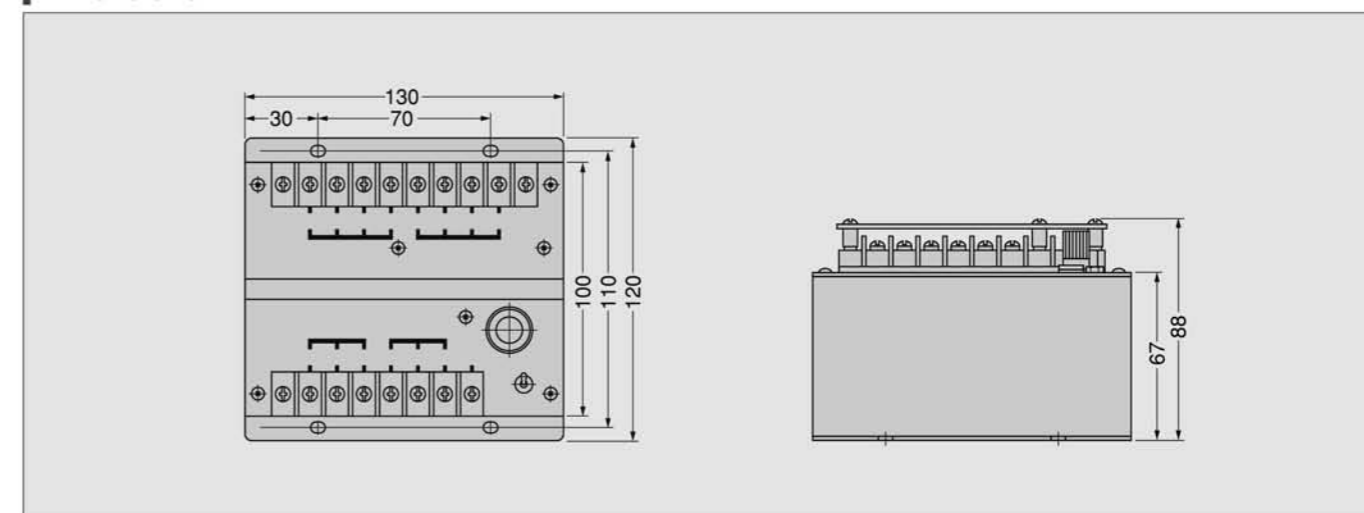

Signal Gauge Set-Up

How to Use

● Signal Gauge (S-5, S-7, S-9)

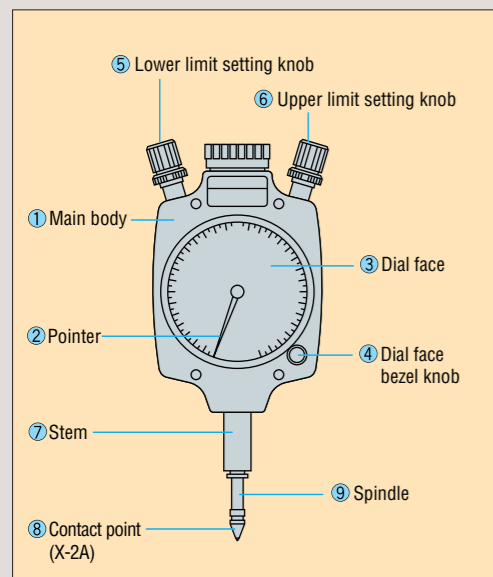

● Instructions

- Prepare a judgement master (standard sample) and hold a signal gauge on a stand, etc.
 - Adjust and fix the position of judgement master so that a gauge pointer indicates zero, and move the contact point ⑧ up and down several times so as to confirm the pointer's stable position.
 - When setting a lower limit of tolerance value, remove the master and turn the lower limit setting knob ⑤ so as to adjust a pointer at a certain graduation.
 - When setting an upper limit of tolerance value, turn the upper limit setting knob ⑥ so as to adjust a pointer at a certain graduation while fully pushing up the contact point ⑧.
 - After setting the upper and lower limit, move the spindle ⑨ up and down several times to confirm that a pointer's indication is within the tolerance value.
- ※ Stem or back cover with lug is used to support the gauge.

● Signal Checker (SC-2A)

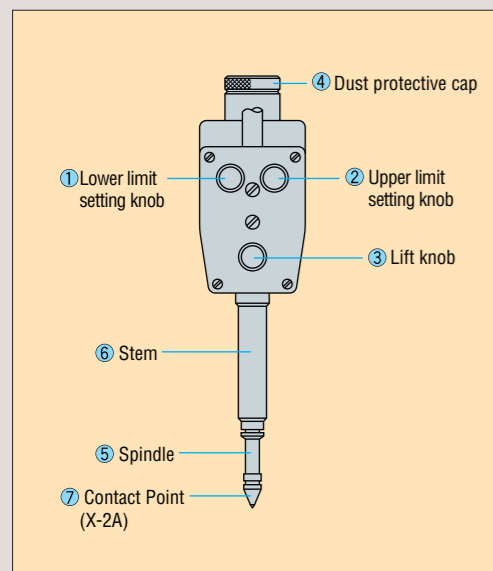

● Instructions

- Prepare a judgement master (standard sample) and hold a signal gauge on a stand, etc.
 - Prepare a dial gauge for setting tolerance value No.107 (0.01mm to 10mm) and remove the dust protective cap ④ by a hexagon wrench attached to the gauge.
 - Turning the lift knob ③ allows the spindle ⑤ to move up and down. The pointer of dial gauge moves according to its movement.
 - Connect this checker with a signal box or a controller.
 - Prepare a judgement master (standard sample), on which push this checker to the position where the lower limit of tolerance value can be set, and fix it by a supporting device.
 - Set the indicator of dial gauge at zero of a dial and turn the lower limit setting knob ① fully in the clockwise direction.
 - Set the upper limit of tolerance value at a certain position while turning the lift knob ③ in the clockwise direction.
 - Turn the upper limit setting knob ② in order to adjust the indications (signals) of signal box or controller to the switching position of OK and +NG at the upper limit of tolerance value.
 - Remove the master and turn the lift knob ③ in the counter clockwise direction to set the lower limit of tolerance value.
 - Turn the lower limit setting knob ① to adjust the indications (signals) of signal box or controller to the switching position of OK and -NG at the lower limit of tolerance value.
 - Move the spindle ⑤ up and down several times by the lift knob ③ to check the right adjustment.
 - After your setting, turn the lift knob ③ in the counter clockwise direction until the spindle ⑤ is fully pushed down.
 - When you use this checker without dial gauge, never forget to mount the dust protective cap ④ on it.
- ※ Stem is used to support this checker.

Signal Gauge Connections Diagram

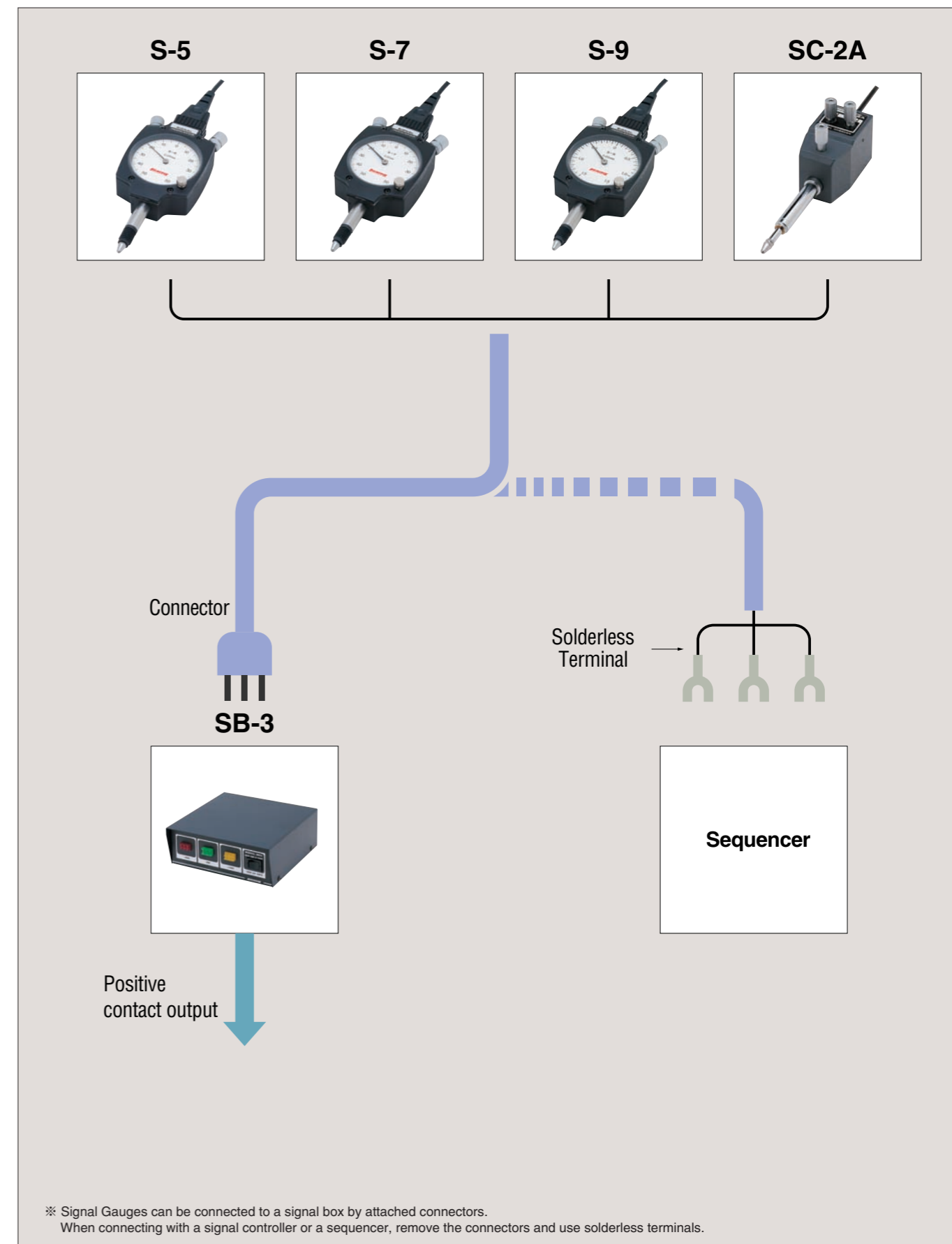

Example of Use

● Measurements of Length and Outer Diameter (glass bottles, etc.)

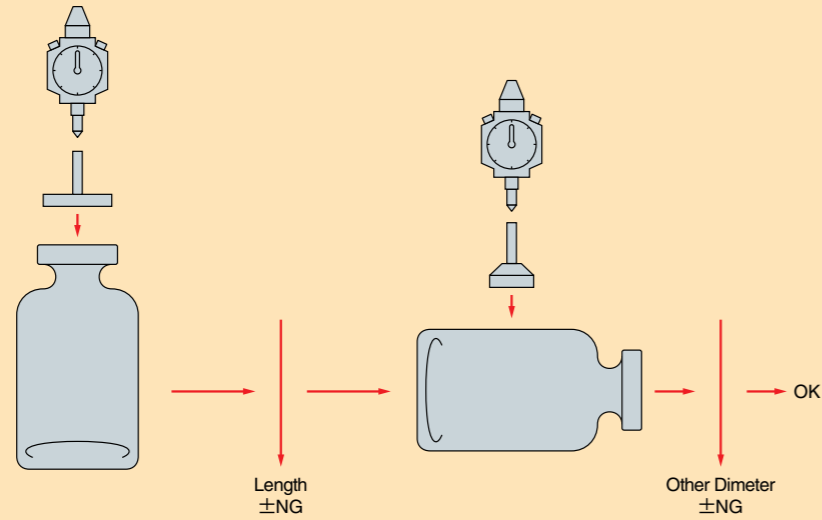

※ After measuring by two signal gauges and two signal boxes, selection (OK, ±NG) is automatically controlled.

● Measurement of Deviation (Wheels, etc.)

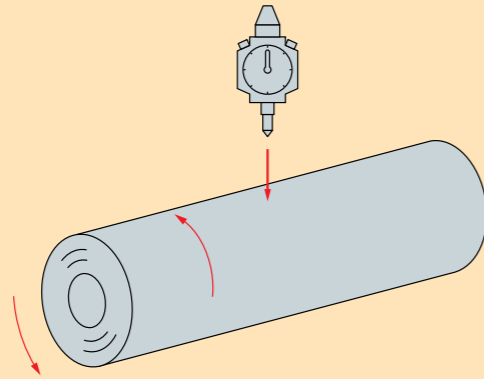

※ Selection (OK, ±NG) is performed while turning an object and measuring its deviation.

● Measurement of Thickness (paper rolls, etc.)

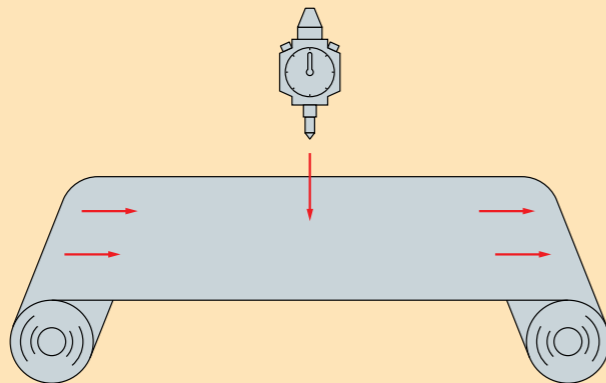

※ Multiple points are measured using a lot of signal gauges and selection (OK, ±NG) is performed by a signal box, or controller.



SECTION

11



Digital Indicators

- Digital Dial Gauge
- Linear Gauge
- Digital Counter
- Application Series
- Deep Hole Bore Gauge
- Technical Glossary

Overview of Digital Gauges & Display Combinations

Measuring range Resolution	2mm	5mm	12.5mm	20(25)mm	50mm	100mm
0.01mm			DG-127	DG-257		
0.001 mm				DG-205	PDN-51 0.001mm (Convertible to 0.01mm)	
				PDN-21 0.001mm (Convertible to 0.01mm)		
0.01mm	DL-2 (Lever Type)	D-5 D-5UZ	D-10 New DN-10	D-20 New DN-20	D-50	D-100
0.001 mm	DL-2S (Lever Type)	D-5S	D-10S New DN-10S	D-20S New DN-20S	D-50S	D-100S
0.0005 mm (0.5 μm)			D-10SS			
0.0001 mm (0.1 μm)			D-10HS			

Display and Supporting Units

Counter
C-500 (Simple function)
C-700 (Multi-function)
CM-5B (Counter with Comparator)
C-500 (Simple function)
C-700 (Multi-function)
CM-5B (Counter with Comparator)
C-7HS (0.1μm Resolution)

RS-232C → 

Digital Indicators

Cordless Type

- The batteries in these digital indicators have a service life of approximately 3000 hours under normal use.
- Digital display can be rotated (approx. 270°) to easily legible positions.
- Very compact, and long 25mm stroke. (DG-257, DG-205)
- RS-232C data output capability.
- No warm-up required. Switch on, and it's immediately ready to use.
- Clear LCD display.



Specifications

Model	DG-127	DG-257	DG-205
Range	12.5mm	25mm	
Resolution	0.01mm		0.001mm
Accuracy (excluding quantized error)	0.01mm		0.003mm
Display (LCD display)	5 digit -999.99 with (-) symbol		6 digit -999.999 with (-) symbol
Measuring force (when correctly positioned)	Less than 0.95N		Less than 1.1N
Operating temperature	+5~40°C		
Battery	One CR2032 type lithium battery (included)		
Data output	RS-232C port (opto-cable sold separately)		
Mounting method	Supported by ϕ 8mm stem, (Lug back, GB-1205 is optional)		
Contact point	M2.5 x 0.45 Thread with carbide ball (XB-1)		
Weight	230g		
Functions	<ul style="list-style-type: none"> ● ZERO RESET-----Resetting to zero at any desired position ● PRESET-----Preset at a desired value ● DATA HOLD-----Data can be held for direct data output to outside computer ● MM/INCH-----Easily switch between metric and inch systems ● Low battery warning display-----"B" signifies low battery (Battery dies within 2~3 hours after "B" is first displayed) ● Display rotation-----Display can be rotated up to 270° for easy reading ● Counting direction conversion-----Plus and minus directions, for spindle movement, can be selected. 		

Dimensions (DG-205/DG-257/DG-127)

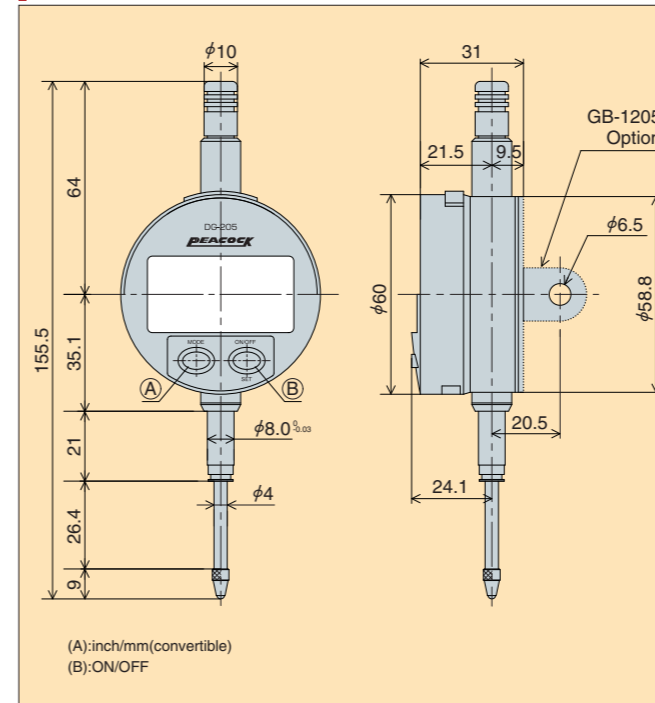

Example of Connection

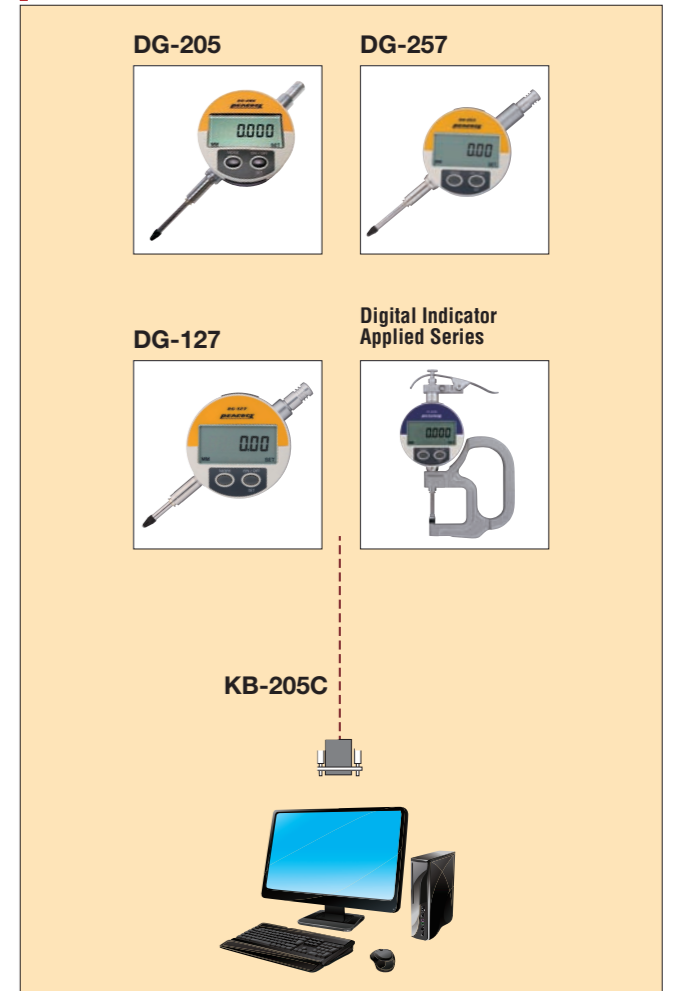

Optional accessories

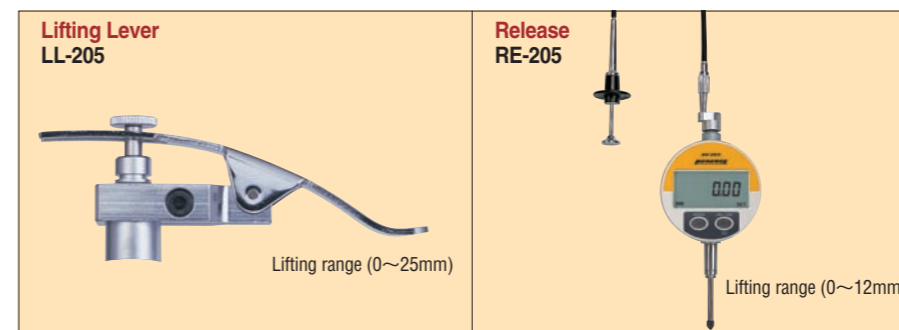
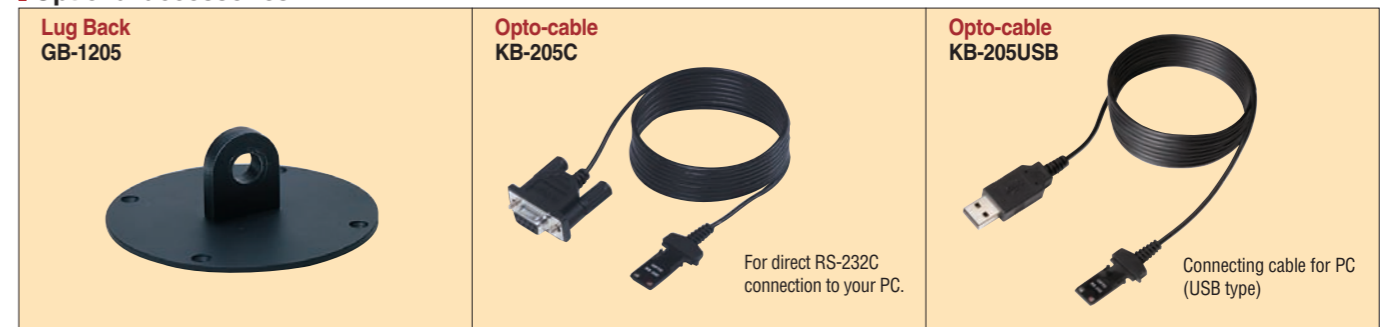

Digital Gauges

Integrated Display Type



PDN-21
Resolution: 0.001mm (convertible to 0.01mm)
Range: 0-20mm



PDN-51
Resolution: 0.001mm (convertible to 0.01mm)
Range: 0-50mm

Options (for PDN-21)

- Flat Back No. GB-3D20
- Finger Lever No. LL-D20
- Release No. RE-4
- Lifting Lever No. LL-PD



Options (for PDN-21 and PDN-51)

- Input Adapter No. IF-21
- Gauge Stand No. SIS-6C

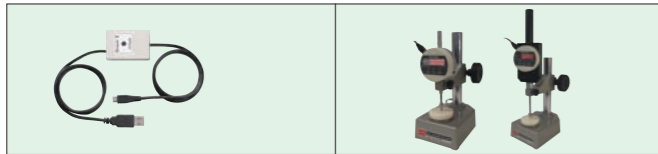

IF-21 can input a measuring data directly to a cell of the spreadsheet such as EXCEL by converting the keyboard signal. The driver is unnecessary as USB terminal connection.

Specifications

Model	PDN-21	PDN-51
Range	20mm	50mm
Resolution	Convertible 0.01mm and 0.001mm (Set 0.001mm at the time of shipment)	
Accuracy (excluding quantized error)	0.001mm Display: 0.003mm 0.01mm Display: 0.01mm	0.001mm Display: 0.004mm 0.01mm Display: 0.01mm
Measuring force	Less than 1.5N (Without Spring: less than 0.31N) Less than 3.0N (Without Spring: less than 1.0N)	
Response speed	1000mm / sec.	
Contact Point	X-2 (M2.5 x 0.45)	X-9 (M2.5 x 0.45)
Display rotation	280°	
Power Supply	AC100 - 240 V±10% 50/60Hz (AC Adapter)	
Operating temperature	0~40°C (no condensation)	
Accessories	● AC Adapter	● AC Adapter ● Finger Lever No. LL-D50
Functions	PDN-21 and PDN-51 ● Convertible 0.01mm and 0.001mm ● Judgement: Three Stage of -NG, OK and +NG (OK : Green, +NG : Red, -NG : Red) ● Counting Direction Conversion	
Data Output	RS-232C	
Options	for PDN-21 ● Flat Back No. GB-3D20 ● Finger Lever No. LL-D20	for PDN-21 and PDN-51 ● Release No. RE-4 ● Lifting Lever No. LL-PD ● Input Adapter No. IF-21

Dimensions (PDN-21 PDN-CC PDN-PP)

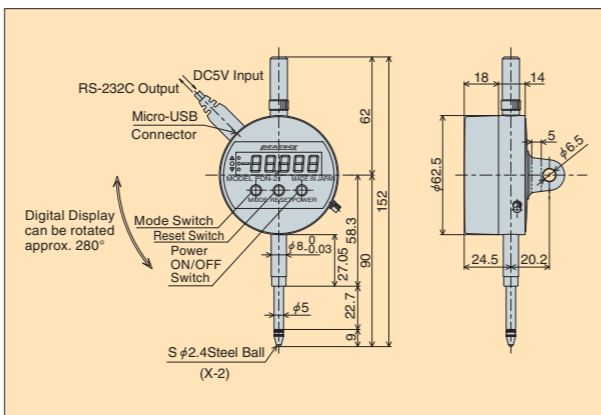

PDN-CC (for Cylinder Gauge)
Resolution: 0.001mm (convertible to 0.01mm)
Range: 0-20mm



PDN-PP (for Measuring Height of Milling Blade)
Resolution: 0.001mm (convertible to 0.01mm)
Range: 0-20mm

Examples (PDN-CC)

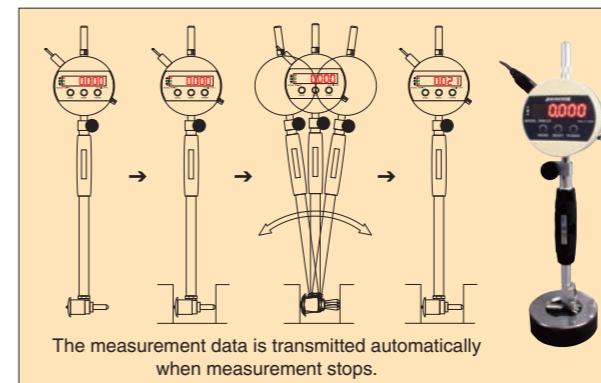

The measurement data is transmitted automatically when measurement stops.

Examples (PDN-PP)

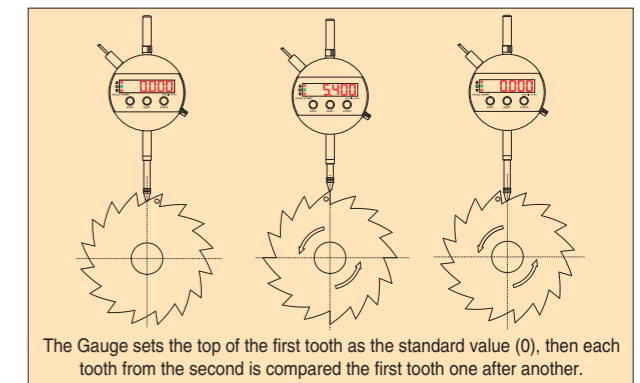

The Gauge sets the top of the first tooth as the standard value (0), then each tooth from the second is compared the first tooth one after another.

Cylinder Gauge is not furnished and supplied only on request.

Cylinder Gauge

CC-series	CG-series
CC-02 (6-10mm)	CG-01 (10-18mm)
CC-01 (10-18mm)	CG-1 (18-35mm)
CC-1 (18-35mm)	CG-2 (35-60mm)
CC-2 (35-60mm)	CG-3 (50-100mm)
CC-3 (50-100mm)	CG-3C (50-150mm)
CC-3C (50-150mm)	CG-4 (100-160mm)
CC-4 (100-160mm)	CG-5 (160-250mm)
CC-5 (160-250mm)	CG-6 (250-400mm)
CC-6 (250-400mm)	

Dimensions (PDN-51)

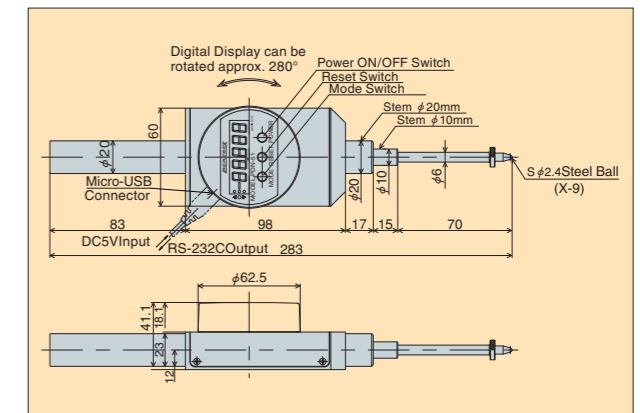

Specifications

Model	PDN-CC	PDN-PP
Range	20mm	20mm
Resolution	Convertible 0.01mm and 0.001mm (Set 0.001mm at the time of shipment)	
Accuracy (excluding quantized error)	0.001mm Display: 0.003mm	0.01mm Display: 0.01mm
Measuring force	Less than 1.5N	
Response speed	1000mm / sec.	
Display rotation	280°	
Power Supply	AC100 - 220 V±10% 50/60Hz (AC Adapter)	
Operating temperature	0~40°C (no condensation)	
Data Output	RS-232C	
Back	Flat back No. GB-3D20	
Functions	for PDN-CC ● Minimum Value Display Minimum Display with Statistical Operation. ● Auto Start : Automatically start to measure. ● Auto Stop: Automatically stop to measure. ● Error Detect: Prevent the error measurement by Error Detect	for PDN-CC and PDN-PP ● Convertible 0.01mm and 0.001mm ● Judgement : Three stage of -NG, OK and +NG (OK : Green, +NG : Red, -NG : Red) ● Counting direction Conversion
Options	Same as PDN-21	

Linear Gauges

Measurement range(0~5mm)

Lever Type

- Best suited for deviation measurement.



DL-2

Resolution: 0.01mm
Range: 0~2mm

DL-2S

Resolution: 0.001mm
Range: 0~2mm

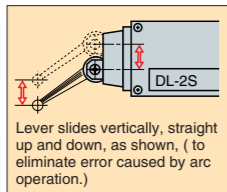

Pencil Type

- Best suited for confined conditions.



D-5

Resolution: 0.01mm
Range: 0~5mm

D-5S

Resolution: 0.001mm
Range: 0~5mm

Contact Point (X-2)

Small Type

- Best suited for work in confined space measurement.



D-5UZ

Resolution: 0.01mm
Range: 0~5mm

Contact Point (X-107)

Specifications

Model	DL-2	DL-2S	D-5	D-5S	D-5UZ
Range	2mm		5mm		5mm
Resolution	0.01mm	0.001mm	0.01mm	0.001mm	0.01mm
Accuracy (excluding quantized error)	0.01mm		0.002mm	0.002mm	0.01mm
Measuring force	Less than 0.6N		Less than 0.5N		Less than 1.0N
Mounting method	φ 6.5mm hole on lug or dovetail at bottom		φ 8mm stem		φ 6.5mm hole on lug back
Contact point	S φ 2mm carbide		S φ 2.4mm steel (X-2)		S φ 2.4mm steel (X-107)
Weight	180g		160g		200g
Cable length	2m (Standard) Option ● Extension cables of 2, 3, 5 and 10 meters are available (see page P.143)				
Operating temperature	0~40°C				
Output signal	90° phase difference, 20μm pitch (R03-PB8M Tajimi connector)				
Features	<ul style="list-style-type: none"> ● Lever type probe is best recommended for measuring TIR or narrow space. ● Contact point easy adjustable to any desired position. 	<ul style="list-style-type: none"> ● Pencil type is especially made for setting up in extremely confined conditions. ● Dust proof rubber attached. Gauge suitable for use in dusty and moist environment. 	<ul style="list-style-type: none"> ● The gauge height is extremely short to fit in limited spaces. ● Set by lug on the back of the gauge (φ 6.5mm hole) 		
Compatible standard counters	C-500 C-700 CM-5B				
Options			<ul style="list-style-type: none"> ● Customer must specify if application is up-side-down. The measuring force changes when the gauge is inverted. 		<ul style="list-style-type: none"> ● Replaceable Contact Point XS-6 ● Other Optional Contact Points

※ Lever moves linearly, unlike the arc movement in a lever type dial indicator.

Dimensions

DL-2/DL-2S

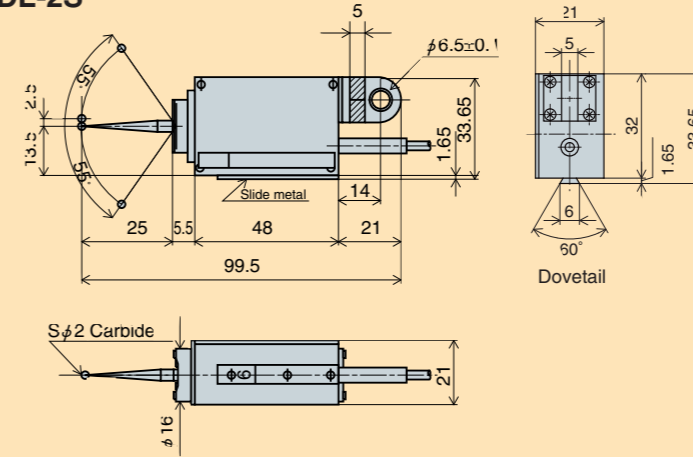

D-5/D-5S

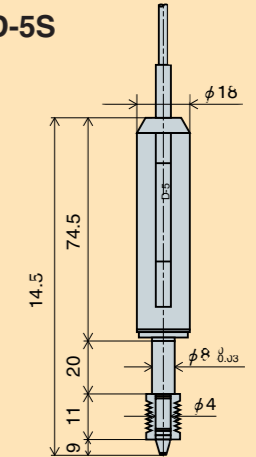

D-5UZ

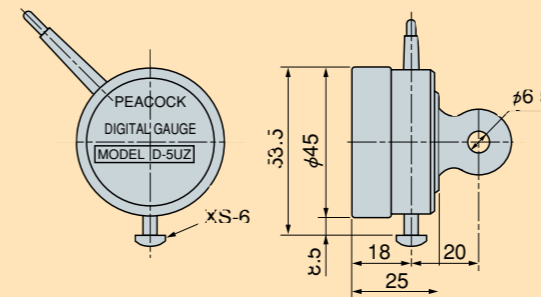

Examples

- Testing TIR (Total Indicator Run-out) of a cylinder

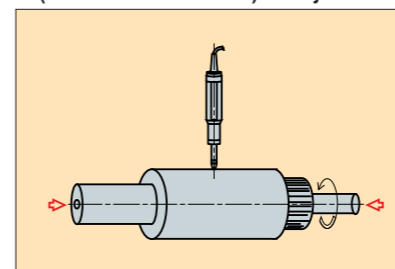

- Multi-point testing of a thick board

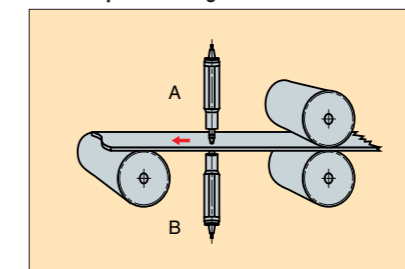

- Internal surface measurement of a cylinder

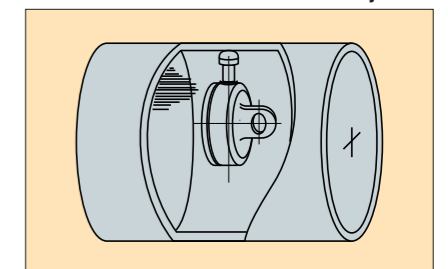

- Measuring Angles

Gauges are set at position X and Y and the difference between them is converted into angle for judgement. (In this example, the left angle of a golf club is measured and printed out)

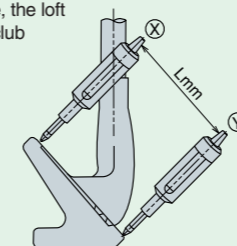

- Multi-Point Measuring

Mount the same number of linear gauges to measure the numbers of points where measurement is needed. Measured data is processed by a multi-counter with CPU and printed out on a printer.

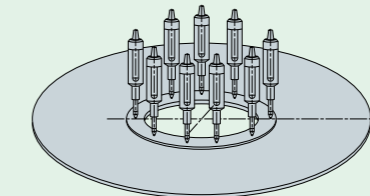

- Measuring Glass Tubes

Outer diameter, thickness, and thickness variation of glass tubes such as fluorescent tubes are measured and displayed. Built-in printer prints out the measured data.

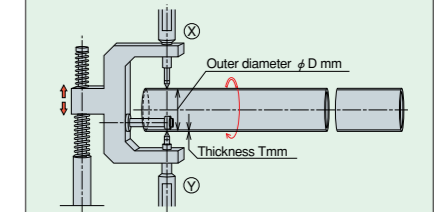

Measurement range (0~10mm, 0~20mm)

- 10mm and 20mm measurement ranges are the easiest to use.
- Used in conjunction with digital counters, these gauges can be set up in places where dial gauges are now being used.
- Set the gauge by either stem or lug back.
- For lifting spindle, both lever and release types are available.

Rectangular wave output type

DN-10 • DN-10S • DN-20 • DN-20S

- For use in electrically noisy environments.
- For applications requiring extra long cables.(10 to 50 meters are available)

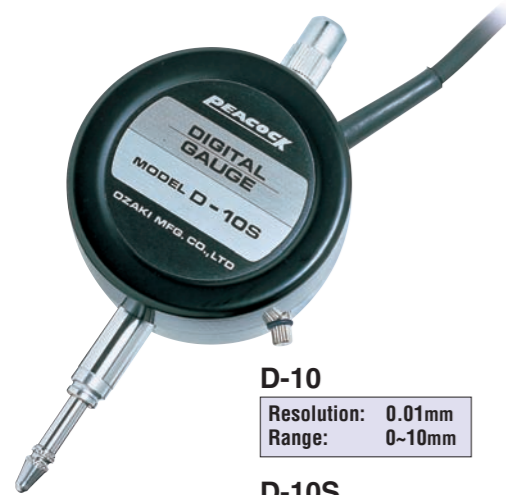

D-10

Resolution: 0.01mm
Range: 0~10mm



DN-10 New

Resolution: 0.01mm
Range: 0~10mm



DN-20 New

Resolution: 0.01mm
Range: 0~20mm

D-10S

Resolution: 0.001mm
Range: 0~10mm

DN-10S New

Resolution: 0.001mm
Range: 0~10mm

DN-20S New

Resolution: 0.001mm
Range: 0~20mm

Output wave-form (DN-10 • DN-20)

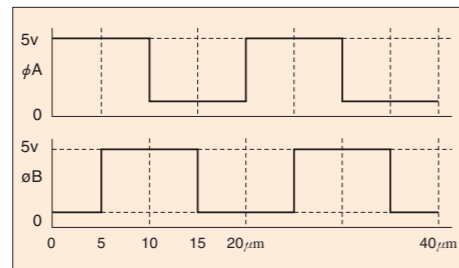

Output wave-form (DN-10S • DN-20S)

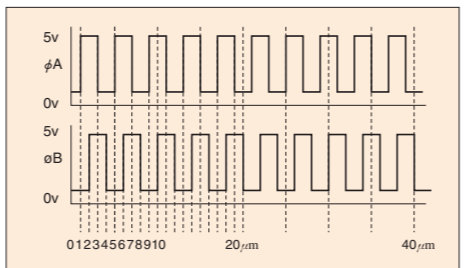

Specifications

Model	D-10	D-10S	DN-10 New	DN-10S New	D-20	D-20S	DN-20 New	DN-20S New
Range	10mm				20mm			
Resolution	0.01mm	0.001mm	0.01mm	0.001mm	0.01mm	0.001mm	0.01mm	0.001mm
Accuracy (excluding quantized error)	0.005mm	0.002mm	0.01mm	0.002mm	0.005mm	0.003mm	0.01mm	0.003mm
Measuring force	Less than 1.0N				Less than 1.5N			
Cable length	2m							
Mounting method	φ 8mm stem or 6.5mm hole on lug back							
Contact point	M2.5 × 0.45 S φ 2.4mm steel (X-2)							
Operating temperature	0~40°C							
Weight	220g				300g			
Output Signal	90° phase difference, 20µm pitch (R03-PB8M Tajimi connector) Rectangular wave (Low=0V High=8V)							
Compatible standard counters	C-500 C-700 CM-5B (*except DN-10S, DN-20S)							
Options	<ul style="list-style-type: none"> ● Release (RE-4) Lifting lever (LL-1) ● Dust proof rubber (BG-10) ● Flat back (GB3-D10), screws (S-110) ● Customer must specify if application is up-side-down. The measuring force changes when the gauge is inverted.				<ul style="list-style-type: none"> ● Release (RE-4) ● Flat back (GB3-D20) ● Customer must specify if application is up-side-down. The measuring force changes when the gauge is inverted.			

*Features
 DN-10 DN-10S DN-20 DN-20S
 ●1 Recommended for locations where cable extension (10 to 50 meters) is necessary.
 ●2 Recommended for use in electrically noisy environments.
 Notes of wiring : A signal wire should be duct wiring apart from other power lines.

Dimensions (D-10 / D-10S / D-10SS / D-20 / D-20S / DN-10 / DN-10S / DN-20 / DN-20S)

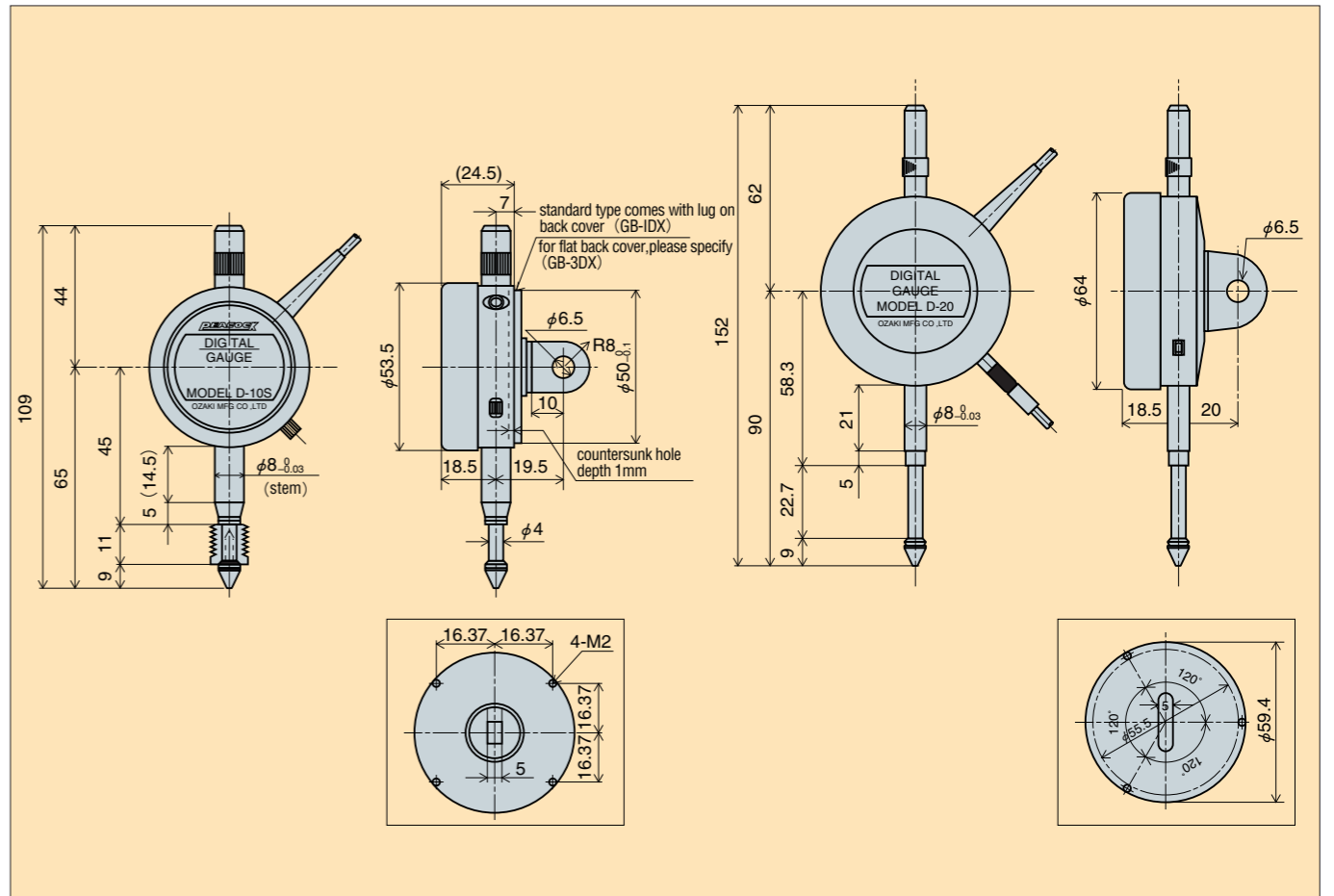

Options

Split collar (WB-1)

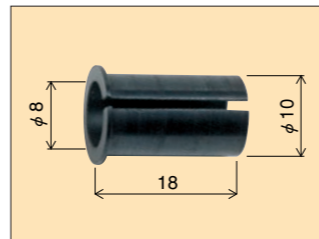

Split collar above is used on the φ 8mm stem during mounting to prevent malfunction due over tightening.
 Securing by means of screw directly in stem may result in malfunction.

Dust proof rubber (BG-10)



Compressible dust proof rubber fits all D-5, D-5S, D-10S, D-10SS, DN-10, DN-10S gauges. (Stroke under 10mm)

Release (RE-4)



Lifting lever (LL-1)

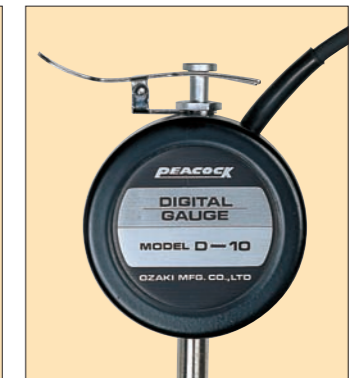

Measurement Range (0~50mm, 0~100mm)

- With very sturdy $\phi 20$ mm stem.
- Ultra-high precision achievable with exclusive gauge stand (PDS-2)

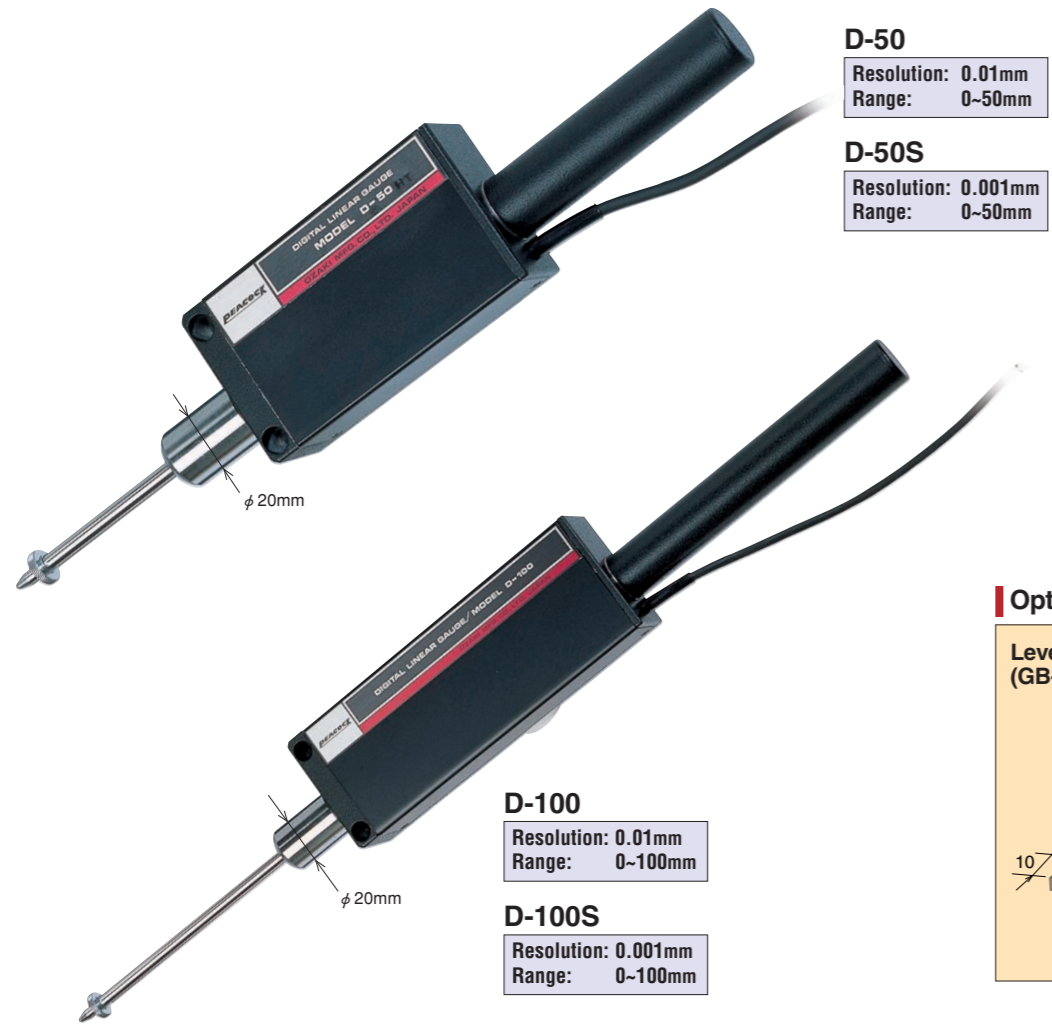

D-50
Resolution: 0.01mm
Range: 0~50mm

D-50S
Resolution: 0.001mm
Range: 0~50mm

D-100
Resolution: 0.01mm
Range: 0~100mm

D-100S
Resolution: 0.001mm
Range: 0~100mm

Option



Specifications

Model	D-50	D-50S	D-100	D-100S
Range	50mm		100mm	
Resolution	0.01mm	0.001mm	0.01mm	0.001mm
Accuracy (excluding quantized error)	0.01mm	0.004mm	0.01mm	0.005mm
Measuring force	Less than 3.0N		Less than 3.5N	
Cable length	2m			
Mounting method	$\phi 20$ mm stem or fastening by M4 screws at two positions			
Contact point	M2.5 \times 0.45 S ϕ 2.4mm steel (X-9)			
Operating temperature	0~40°C			
Weight	450g		520g	
Output signal	90° phase difference, 20 μ m pitch (R03-PB8M Tajimi connector)			
Compatible standard counters	C-500 C-700 CM-5B			
Accessories	● Finger lever for lifting spindle (LL-D50)1 pc			
Features	● If Spindle inner spring is removed, measuring force will be that of spindle itself (only when in upright position) ● D-50, D-50S1.0N (100gf) D-100, D-100S1.1N (110gf) ● Recommended Gauge stand is PDS-2			
Option	● Level mounting clamp (GB-50) see page 141 ● Customer must specify if application is up-side-down. The measuring force changes when the gauge is inverted.			

Special Gauges

For High Temperature Applications D-50HT (0.01mm Resolution)



This special gauge can be used up to +65°C temperature. 0.01mm (0.005mm) Resolution (D-50S is not suited for high temperature)

For Dusty Applications D-50WA D-50SWA



Dust-proof rubber protects spindle. Equivalent to IP-54. (Protection against oil & water is not available)

For Dusty Applications D-100WA D-100SWA



Dimensions (D-50 / D-50S / D-50HT)

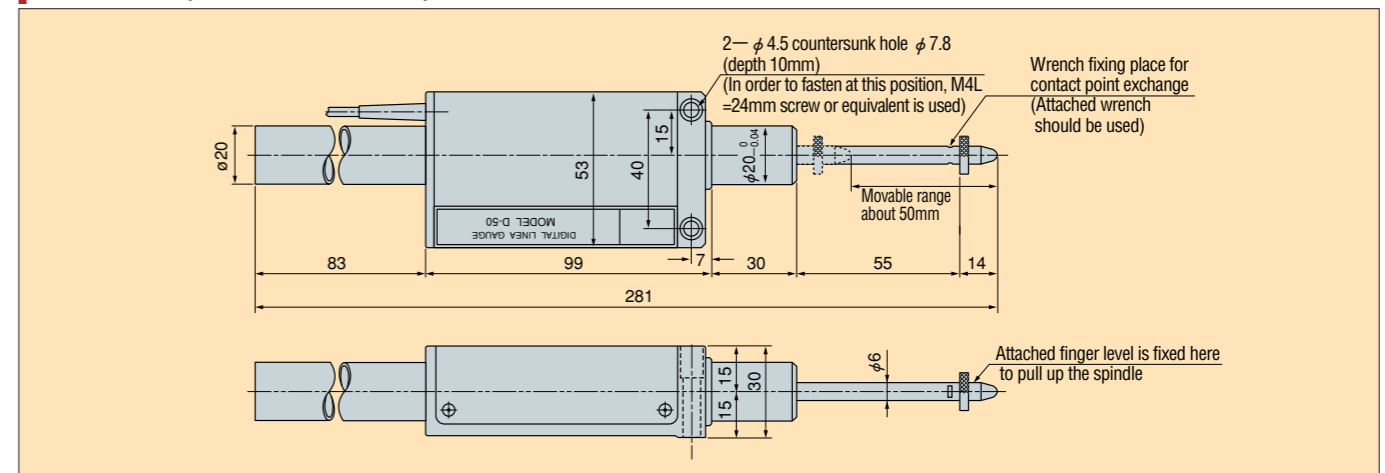

Dimensions (D-100 / D-100S)

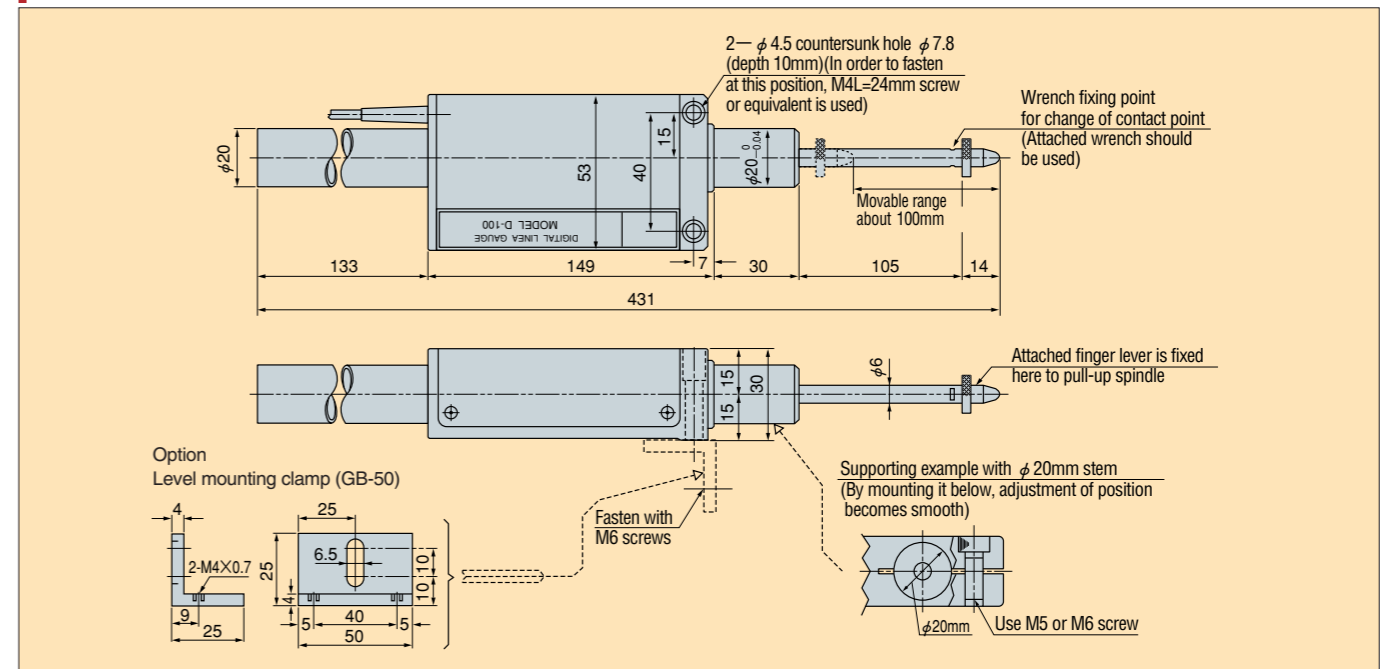

11 High Resolution Type 0.1μm and 0.5μm

- Use of linear scale improves accuracy and reduces error due temperature influences.



D-10SS
Resolution: 0.0005mm(0.5μm)
Range: 0~10mm

D-10HS
Resolution: 0.0001mm(0.1μm)
Range: 0~10mm
● With spindle pull-up back lever

Specifications

Model	D - 10SS	D - 10HS
Range	10mm	10mm
Resolution	0.0005mm	0.0001mm
Accuracy (excluding quantized error)	0.001mm	0.0005mm
Measuring force	Less than 1.0N	
Cable length	2m	
Operating temperature	0~40°C	
Contact point	M2.5 × 0.45 S φ 2.4mm steel (X-2)	M2.5 × 0.45 S φ 2.4mm steel (X-2)
Mounting method	φ 8mm stem or back cover with lug(φ 6.5mm hole)	φ 8mm (no provision for back cover with lug mounting)
Weight	220g	200g
Output signal	90° phase difference, 8μm pitch (R03-PB8M Tajimi connector)	90° phase difference, 8μm pitch (approximate Sinusoidal wave) (R03-PB8M Tajimi connector)
Compatible standard counters	C-7HS	
Accessories	<ul style="list-style-type: none"> ● Release (RE-4) ● Back cover with lug (GB-1DX) 	Spindle pull-up back lever (exclusively for D-10HS)
Options	<ul style="list-style-type: none"> ● Accuracy list ● Parallel adjustment Contact point (X-10) ● Gauge stand (PDS-2) 	<p>X-10 When using 'Flat' contact point, choose contact point which has parallel adjustment in relation to anvil surfaces as shown in picture.</p>

Dimensions (D-10HS)

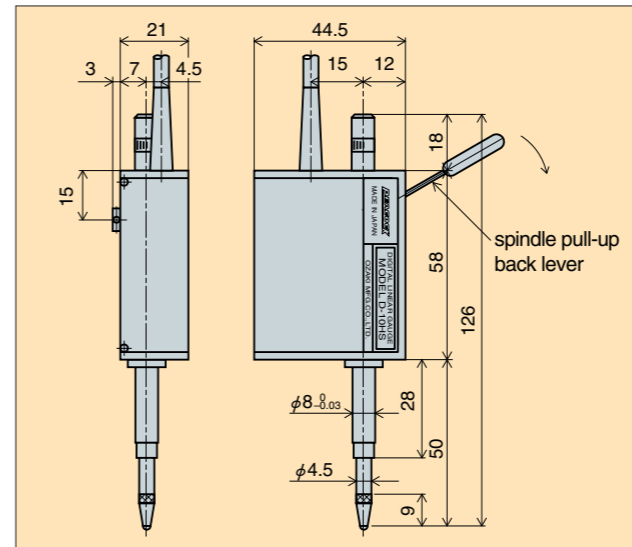

Extension cables for Linear Gauges

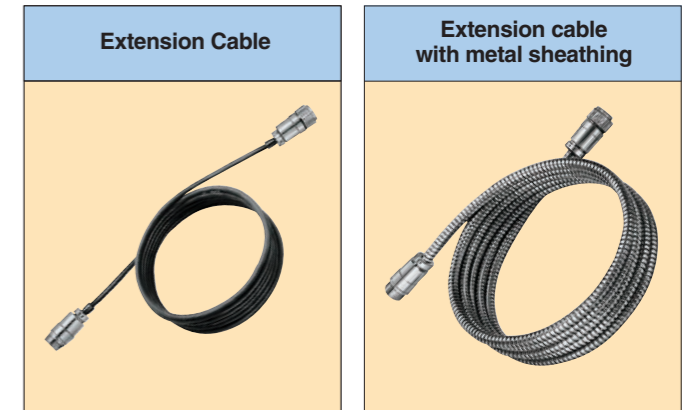

2, 3, 5 and 10 meters are standard length.

2 and 3 meters are standard length.

Common Specifications of Linear Gauges

Items	Common specifications
Type of gauges	DL-2S, D-5S, D-10S, D-20S, D-50S, D-100S DL-2, D-5, D-10, D-20, D-50, D-100, D-5UZ
Displacement transducer type	Glass linear scale (scale pitch 20μm) (D-10SS·D-10HS: pitch 8μm)
Power supply	+12DCV ±5% (consumed current 40mA)
Signal cable length	2m (2,3,5 and 10m extension cables are available) 4 core shield cable & oil proof type
Output connector, Receiver connector	Gauge side (R03-PB8M) Counter side (R03-R8F) Tajimi connectors
Output signal (A) 1μm resolution	2 phase signal with 90° phase difference, 20μm pitch, sinusoidal wave-form
Output signal (B) 5μm/10μm resolution	2 phase signal with 90° phase difference, 20μm pitch, approximate sinusoidal wave-form
Output signal (C) 5μm/10μm resolution	2 phase signal with 90° phase difference, 20μm pitch, square wave-form (gauges: DN-10, DN-20)
Output signal (D) 0.5μm/0.1μm resolution	2 phase signal with 90° phase difference, 8μm pitch, sinusoidal wave-form (gauges: D-10SS, D-10HS)
Operating temperature	0~40°C (except for high temperature type)
Output Frequency	0~50KHz
Contact point	M2.5 x 0.45 (contact points for dial gauge can be used)

Output signal (A) wave-form (1μm resolution)

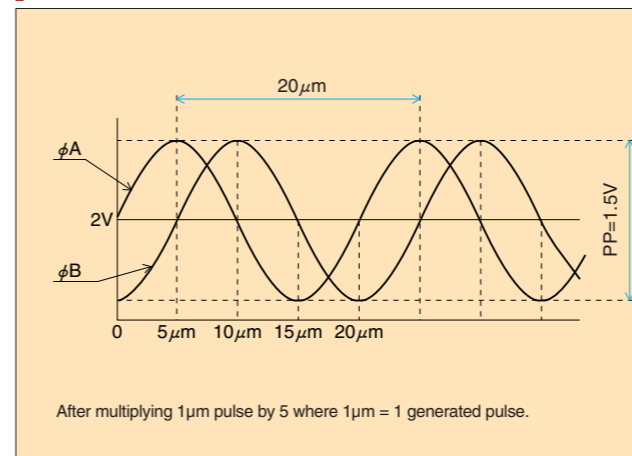

Signal Connector R03-PB8M (manufactured by Tajimi)

Pin arrangement

Pin No.	Signal	Wire Color
A	GND	black
B	φ A	blue
C	+12V	red
D	φ B	white
E	NC	unused
F	shielded wire (FG)	
G	NC	unused
H	NC	unused

Digital Counters

New Type

Equipped with large display functions and various measurement functions, our Digital Counters can be installed in a Control Panel or placed on a desk due to their compact designs.



Simple type
Priority on user friendliness.
C-500



Multi-type
User friendliness combined with multi-functionality.
C-700

1/2 Display (C-500/C-700)

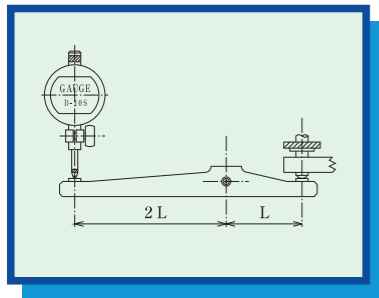

Displays the displacement after halving it.

×2 Display (C-500/C-700)

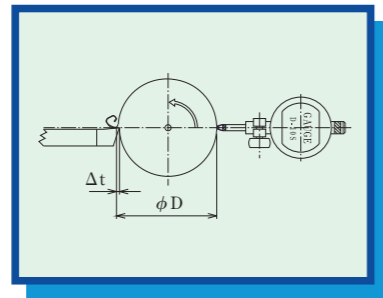

Displays the displacement after doubling it.

Inch Display (C-500/C-700)

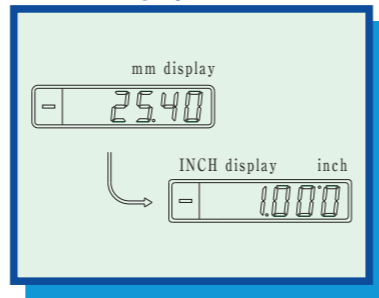

Displays the displacement in terms of inches.

Data Output (C-500/C-700)

(Standard function of RS-232C, optional function of BCD)

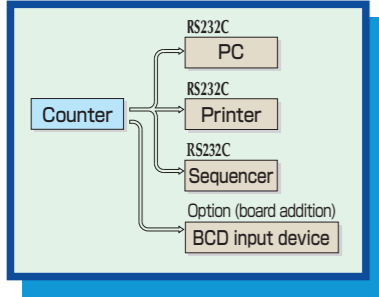

Outputs data

Presetting (C-700)

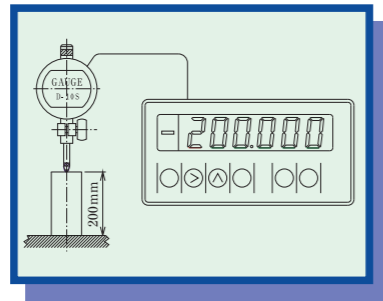

Displays preset values.

OK±NG Judgment (C-700)

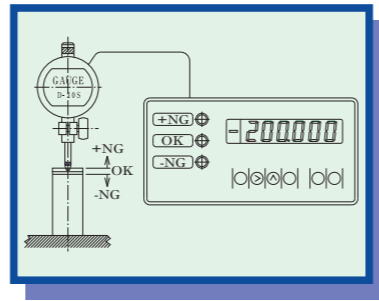

Outputs OK±NG judgment.

Maximum Value Display (C-700)

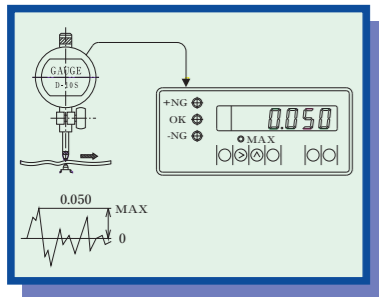

Holds the maximum positive value and makes OK±NG judgment.

Minimum Value Display (C-700)

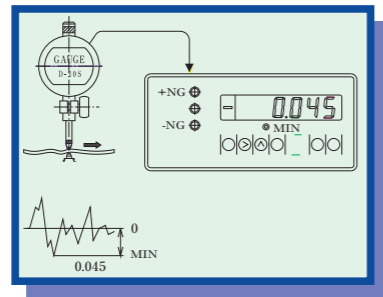

Holds the minimum negative and makes OK±NG judgment.

Deflection Measurement Display (C-700)

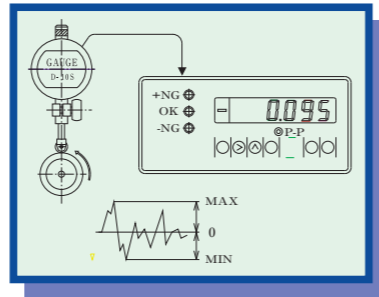

Holds the difference between the maximum and minimum values (deflection) and makes OK±NG judgment.

Specifications of Digital Counters

Model	Model No. C-500	Model No. C-700																															
Displayed digits	* Selection of 10 μm * Selection of 1 μm	—9999.99~00.00~9999.99 —999.999~0.000~999.999																															
Display	High-luminance LED display with 7segments (red)																																
Power supply voltage & power consumption	AC100V~AC240V · 9VA or lower																																
Operating temperature	0~+40°C																																
Compatible Linear Gauges	DL-2 D-5 D-10 D-20 D-30 D-50 D-100 DN-10 DN-20 D-5UZ DL-2S D-5S D-10S D-20S D-30S D-50S D-100S DN-10S DN-20S																																
Accessories	<ul style="list-style-type: none"> ◆AC power cord (2m): One cord ◆Metal fittings for panel installation: Two units (to be used for installation in panel and securing stand fittings) ◆Stand fittings: One unit (to be used when counter is used as desktop device) 																																
Terminal block functions (Rear panel)	<ul style="list-style-type: none"> ◆Terminal block: Screwless terminal block ◆Usable electric cables: AWG22-28 ◆Length of peeled wire of cables: 8~9mm ◆Pin alignment <table border="1"> <tr> <td>*1</td> <td>St/Sp</td> <td>Controls "START" and "STOP" of MAX, MIN, P-P measurement mode.</td> </tr> <tr> <td>*2</td> <td>React</td> <td>Controls "SUSPEND" and "START" of P-P measurement mode.</td> </tr> <tr> <td>3</td> <td>Latch</td> <td>Controls "LATCH" and "CANCEL" of measured value.</td> </tr> <tr> <td>4</td> <td>Reset</td> <td>External "RESET" "PRESET" (Function available only in Model No. C-700)</td> </tr> <tr> <td>5</td> <td>Alarm</td> <td>Error signal output</td> </tr> </table> <table border="1"> <tr> <td></td> <td>Max Display</td> <td>Min Display</td> <td>P-P Display</td> </tr> <tr> <td>*6</td> <td>+NG (2)</td> <td>-NG (1)</td> <td>NG (2)</td> </tr> <tr> <td>*7</td> <td>OK</td> <td>OK</td> <td>OK</td> </tr> <tr> <td>*8</td> <td>+NG (1)</td> <td>-NG (2)</td> <td>NG (1)</td> </tr> </table> <p>(1):NG output in first stage (2):NG output in second stage</p>		*1	St/Sp	Controls "START" and "STOP" of MAX, MIN, P-P measurement mode.	*2	React	Controls "SUSPEND" and "START" of P-P measurement mode.	3	Latch	Controls "LATCH" and "CANCEL" of measured value.	4	Reset	External "RESET" "PRESET" (Function available only in Model No. C-700)	5	Alarm	Error signal output		Max Display	Min Display	P-P Display	*6	+NG (2)	-NG (1)	NG (2)	*7	OK	OK	OK	*8	+NG (1)	-NG (2)	NG (1)
*1	St/Sp	Controls "START" and "STOP" of MAX, MIN, P-P measurement mode.																															
*2	React	Controls "SUSPEND" and "START" of P-P measurement mode.																															
3	Latch	Controls "LATCH" and "CANCEL" of measured value.																															
4	Reset	External "RESET" "PRESET" (Function available only in Model No. C-700)																															
5	Alarm	Error signal output																															
	Max Display	Min Display	P-P Display																														
*6	+NG (2)	-NG (1)	NG (2)																														
*7	OK	OK	OK																														
*8	+NG (1)	-NG (2)	NG (1)																														
Dip sw setting functions (Printed circuit board)	<table border="1"> <tr> <td colspan="2">Dip (1)</td> <td colspan="2">Dip (2)</td> </tr> <tr> <td>SW 1</td> <td>Select 1 μm or 10 μm</td> <td>SW 1</td> <td>Settings by Manufacturer</td> </tr> <tr> <td>SW 2</td> <td>Select direction of counting.</td> <td>SW 2</td> <td>Select whether or not to include default values for OK ±NG judgment.</td> </tr> <tr> <td>SW 3</td> <td>Select activation or non activation of error output.</td> <td>SW 3</td> <td>Select either "orthogonal" or "sine" for input waveform.</td> </tr> <tr> <td>SW 4</td> <td>Select activation or non activation of overflow.</td> <td>SW 4</td> <td>Select either 400msec or 100msec for RESET time.</td> </tr> </table>		Dip (1)		Dip (2)		SW 1	Select 1 μm or 10 μm	SW 1	Settings by Manufacturer	SW 2	Select direction of counting.	SW 2	Select whether or not to include default values for OK ±NG judgment.	SW 3	Select activation or non activation of error output.	SW 3	Select either "orthogonal" or "sine" for input waveform.	SW 4	Select activation or non activation of overflow.	SW 4	Select either 400msec or 100msec for RESET time.											
Dip (1)		Dip (2)																															
SW 1	Select 1 μm or 10 μm	SW 1	Settings by Manufacturer																														
SW 2	Select direction of counting.	SW 2	Select whether or not to include default values for OK ±NG judgment.																														
SW 3	Select activation or non activation of error output.	SW 3	Select either "orthogonal" or "sine" for input waveform.																														
SW 4	Select activation or non activation of overflow.	SW 4	Select either 400msec or 100msec for RESET time.																														
Data output (RS-232C) D-Sub9P plug INCH screw	<ul style="list-style-type: none"> ◆Pin Alignment <table border="1"> <tr> <td>1</td> <td>NC</td> <td>—</td> </tr> <tr> <td>2</td> <td>Rxd</td> <td>in←</td> </tr> <tr> <td>3</td> <td>Txd</td> <td>→out</td> </tr> <tr> <td>4</td> <td>NC</td> <td>—</td> </tr> <tr> <td>5</td> <td>SG</td> <td>—</td> </tr> <tr> <td>6</td> <td>NC</td> <td>—</td> </tr> <tr> <td>7</td> <td>RTS</td> <td>→out</td> </tr> <tr> <td>8</td> <td>CTS</td> <td>in←</td> </tr> <tr> <td>9</td> <td>NC</td> <td>—</td> </tr> </table> <ul style="list-style-type: none"> ◆Communication mode: Half-duplex asynchronous communication ◆Communication speed: 9600bps ◆Format: 7Bit ASCII ◆Parity: even number ◆Stop bit: 1Bit ◆RTS/CTS: Returned when not in use. ◆Reception command: Transmission request ASCII [T] [t] : Reset ASCII [R] [r] ◆Connection cables: Cross cables (not included) 		1	NC	—	2	Rxd	in←	3	Txd	→out	4	NC	—	5	SG	—	6	NC	—	7	RTS	→out	8	CTS	in←	9	NC	—				
1	NC	—																															
2	Rxd	in←																															
3	Txd	→out																															
4	NC	—																															
5	SG	—																															
6	NC	—																															
7	RTS	→out																															
8	CTS	in←																															
9	NC	—																															
Options	<ul style="list-style-type: none"> * BCD output board ◆CB-BCD Can not be used in combination with RS-232C output. 																																
Display functions	<ul style="list-style-type: none"> ◆1/1 display: Displays the measured value as is. ◆1/2 display: Displays the measured value after halving it. ◆×2 display: Displays the measured value after doubling it. ◆INCH display: Displays the value after converting it into inches. <p>Note: With 1 μm display and ×2 display, the lowest digit will be displayed as an even number.</p>																																
Presetting display function	◆Zero setting only	◆Can display preset values																															
Measurement mode function [MAX] [MIN] [P-P]	—	<ul style="list-style-type: none"> ◆Current value display ◆Maximum value(Max) ◆Minimum value(Min) ◆Deflection(P-P) <p>RESET action is taken by ST of the ST/SP control terminal.</p>																															
OK±NG judgment function (Refer to terminal output circuit)	—	<ul style="list-style-type: none"> ◆Current value mode: +NG OK -NG ◆Maximum value mode: OK +NG(1) +NG(2) ◆Minimum value mode: OK -NG(1) -NG(2) ◆Deflection mode: OK NG(1) NG(2) 																															
Dimensions & weight	◆144(W)×72(H)×160(D)mm	◆950g																															

Time Chart [Model No.C-700]

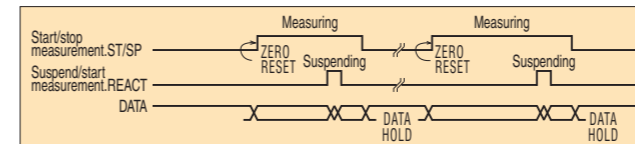

Control Terminal Input Circuit

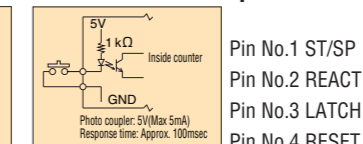

Terminal Output Circuit

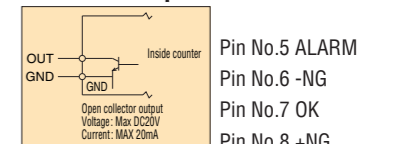

11 with High Resolution

- Resolution capability of 0.1μm / 0.5μm.
- Recommended for very high precision measurement.



C-7HS
Resolution: 0.0001mm (0.1μm) / 0.0005mm (0.5μm)

Specifications

Model	C-7HS
Resolution	0.0001mm (0.1μm) / 0.0005mm (0.5μm) Please specify either 0.0005mm or 0.0001mm display at the time of purchase.
Display	6 digits display with ± sign ±99.9999
Response speed	100mm / sec
Weight	2.6kg
Display	Green fluorescent light display
Power supply	AC100V~AC240V (90~100V) 50/60Hz
Dimensions	200 (W) × 230 (D) × 60 (H) mm
Operating temperature	0 to 40°C / storage, at -5 to 50°C
Compatible linear gauges	0.0001mm : D-10HS / 0.0005mm : D-10SS
Accessories	● Built-in tilt stand (tilts the front of the counter up at slight angle for easier reading)
Functions	<ul style="list-style-type: none"> ● RESET.....For zero reset at any desired position ● DIRECTION.....Numerical direction can be changed by DIRECTION switch located on back panel ● CLOCK OUT..... Outputs BCD's signal simultaneously (1μsec) ● ALARM OUT..... Output abnormal value when response speed is exceeded ● LATCH IN..... Holds the display value and external output data ● RESET IN..... For zero reset from external unit via its RESET input
Data output (RS-232C/BCD OUT)	<ul style="list-style-type: none"> ● Output by positive logic, parallel digits and open collector ● Connector..... 57-40360 DDK equivalent connector (amphenol type) should be used. It is not attached on the cable side. (57-30360 equivalent connector is recommended)
Options	<ul style="list-style-type: none"> ● Printer (PDP-1N)..... Statistic operation ● External RESET / LATCH function: C-7HS-RL.

11 with Judgement Function

- Equipped with Judgement function OK, ±NG (No Go).
- Either 10μm or 1μm resolution setting can be selected.
- 2X or 1/2 X Display magnification.



CM-5B
Resolution: 0.005mm / 0.001mm convertible

Specifications

Model	CM-5B				
Resolution	0.005mm or 0.001mm select by conversion switch				
Display capacity	For 0.005mm, 0 ~ ±199.995mm For 0.001mm, 0 ~ ±199.999mm				
Judgement setting display	Lower and Upper limit setting via digital switch of 6 digits each				
Response speed	1000mm / sec at 0.005mm setting 600mm / sec at 0.001mm setting				
Quantizing error	±1 count				
Judgement Output	Output from relay contact point (a contact point) (DS1-S-DC5V Matsushita or equivalent product)				
Judgement Display	-NG (Yellow), OK (Green) & +NG (Red)				
Operating temperature	0 to 40°C / for storage, at -10 to 50°C				
Power supply	AC100V~AC240V (90V ~ 110V) 50/60Hz				
Weight / Dimensions	2.2kg 200 (W) × 230 (D) × 70 (H) mm				
Functions	<ul style="list-style-type: none"> ● User selectable resolution (0.001mm at time of shipment). ● Equipped with failure alarms (When counting error or gauge fails, display blinks) ● Judgement output is constantly on (control output is possible with an additional optional connector) ● Setting values for judgement is included in ±NG at shipment (Changeable) ● BCD output can be connected to, for example, a sequencer by using open collector. 				
Data output (RS-232C/BCD OUT)	<ul style="list-style-type: none"> ● Output by positive logic, parallel digits and open collector ● Connector..... 57-40360 DDK equivalent connector should be used. It is not attached on the cable side. 				
Compatible linear gauges	<table border="1"> <thead> <tr> <th>At 0.005mm setting</th> <th>At 0.001mm setting</th> </tr> </thead> <tbody> <tr> <td>DL-2, D-5, D-10, D-20, D-50, D-100, D-5UZ, DN-10, DN-20</td> <td>DL-2S, D-5S, D-10S, D-20S, D-50S, D-100S</td> </tr> </tbody> </table>	At 0.005mm setting	At 0.001mm setting	DL-2, D-5, D-10, D-20, D-50, D-100, D-5UZ, DN-10, DN-20	DL-2S, D-5S, D-10S, D-20S, D-50S, D-100S
At 0.005mm setting	At 0.001mm setting				
DL-2, D-5, D-10, D-20, D-50, D-100, D-5UZ, DN-10, DN-20	DL-2S, D-5S, D-10S, D-20S, D-50S, D-100S				
Accessories	● Judgement output connector 1 pc. (PRC03-12A10-4F10.5 Tajimi brand)				
Options	<ul style="list-style-type: none"> ● Additional pass / fail detection control connector (attachable to the back panel). Includes CM-5B-CONT. ● External RESET / LATCH connector is added (on back panel). CM-5B-RL. ● Tilt stand is added (for tilting display for easy viewing). CM-5B-ST. 				
Mounting Precaution	When mounting into rack requires the removal of bottom rubber support, screws must be applied at regular intervals. (Avoid screws penetration into body as damage to printed circuit board is high)				

Printer

11

- Printing of statistically processed data is vital for quality management.
- Input of date and time via front control panel data keys for quality assurance data purposes.
- Items for statistic operation maybe selected from Mode 0 to 1



Specifications

Description			
Number of channels	1		
Maximum no. of date	99		
Printing method	Dot matrix graphic		
Recording paper	Roll (38mm wide X 28mm dia.)		
Power supply	AC adapter (AC100V~AC240V 50/60Hz)		
Operating temperature	0~40°C		
Outer dimensions	130(W) X 170(D) X 61(H) mm		
Weight	1kg		
Accessories	<ul style="list-style-type: none"> ● Recording paper.....1 roll ● AC adapter.....1 pc 		
Options	<ul style="list-style-type: none"> ● Foot switch (FW-1) ● Connecting cable (for signal input) 		
Method of date input	BCD positive logic parallel/serial RS-232C port		
Print-out and calculation categories	<table border="0"> <tr> <td> <ul style="list-style-type: none"> Ⓐ Measuring date Ⓐ Each data Ⓐ Max data Ⓐ Min data Ⓐ Range (R) Ⓑ Defect rate (BAD) Ⓑ Frequency distribution table Ⓑ Diagram </td> <td> <ul style="list-style-type: none"> Ⓐ Number indicating measured data Ⓐ Number of measured data (n) Ⓐ Mean value (X) Ⓐ Standard deviation (σ) Ⓑ Process capability index (Cp) Ⓑ Printing in red for abnormal value Ⓑ Histogram </td> </tr> </table>	<ul style="list-style-type: none"> Ⓐ Measuring date Ⓐ Each data Ⓐ Max data Ⓐ Min data Ⓐ Range (R) Ⓑ Defect rate (BAD) Ⓑ Frequency distribution table Ⓑ Diagram 	<ul style="list-style-type: none"> Ⓐ Number indicating measured data Ⓐ Number of measured data (n) Ⓐ Mean value (X) Ⓐ Standard deviation (σ) Ⓑ Process capability index (Cp) Ⓑ Printing in red for abnormal value Ⓑ Histogram
<ul style="list-style-type: none"> Ⓐ Measuring date Ⓐ Each data Ⓐ Max data Ⓐ Min data Ⓐ Range (R) Ⓑ Defect rate (BAD) Ⓑ Frequency distribution table Ⓑ Diagram 	<ul style="list-style-type: none"> Ⓐ Number indicating measured data Ⓐ Number of measured data (n) Ⓐ Mean value (X) Ⓐ Standard deviation (σ) Ⓑ Process capability index (Cp) Ⓑ Printing in red for abnormal value Ⓑ Histogram 		
Function of print-out according to mode	MODE-0.....Operation printing of Ⓐ items MODE-1.....Operation printing of Ⓐ to Ⓑ		

Discontinued

Connecting cable selection list

Model	Applicable measuring equipment or device
KB-C12	C-7HS
KB-C232	C-700 C-500
KB-CM12	CM-5B
KB-P12	PDN-21 PDN-51
KB-C205 (with connector)	DG-127 DG-205 DG-257

Applied Digital Indicators

Digital Thickness Gauges (0.01mm, 0.001mm)

11

- The thickness of small parts etc. can be quickly measured by lever operation.
- Contact Point and Anvil can be modified made to order.



G2-205 · G2-257 · G2-127

Resolution and Range
(0.001×20mm) · (0.01×20mm) · (0.01×10mm)



G2-205M · G2-257M · G2-127M

Resolution and Range
(0.001×20mm) · (0.01×20mm) · (0.01×10mm)



G2-205A · G2-257A · G2-127A

Resolution and Range
(0.001×20mm) · (0.01×20mm) · (0.01×10mm)

Dimensions

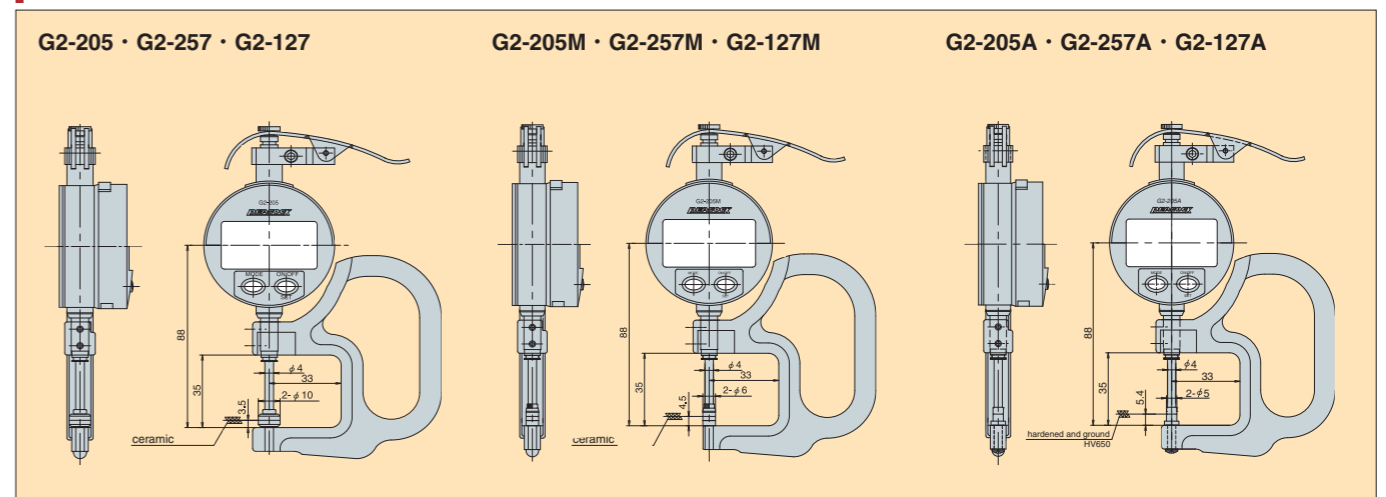

Specifications

Model	Resolution (mm)	Accuracy (excluding quantized error) (mm)	Gauge type	Measuring range (mm)	Measuring depth (mm)	Measuring force (N)	Contact point diameter (mm)	Contact point parallelism (mm)	Anvil diameter (mm)
G2-205	0.001	±0.008	DG-205	20	33	Less than 1.1	ø10	Less than 0.005	ø10
G2-257	0.01	±0.02	DG-257	20	33	Less than 1.1	ø10	Less than 0.01	ø10
G2-127	0.01	±0.02	DG-127	10	33	Less than 0.95	ø10	Less than 0.01	ø10
G2-205M	0.001	±0.008	DG-205	20	33	Less than 1.1	ø6	Less than 0.005	ø6
G2-257M	0.01	±0.02	DG-257	20	33	Less than 1.1	ø6	Less than 0.01	ø6
G2-127M	0.01	±0.02	DG-127	10	33	Less than 0.95	ø6	Less than 0.01	ø6
G2-205A	0.001	±0.008	DG-205	20	33	Less than 1.1	ø5	Less than 0.005	ø5
G2-257A	0.01	±0.02	DG-257	20	33	Less than 1.1	ø5	Less than 0.01	ø5
G2-127A	0.01	±0.02	DG-127	10	33	Less than 0.95	ø5	Less than 0.01	ø5

Applied Digital Gauges

Digital Thickness Gauges (Large Type), Digital Sheet Gauge

- Due to having throat depth 150mm or 300mm can measure a thickness at the center of wide sheets such as paper, urethane, vinyl, rubber and foil etc.
- Contact Point and Anvil can be modified made to order.



JA-205
Resolution: 0.001mm
Range: 20mm

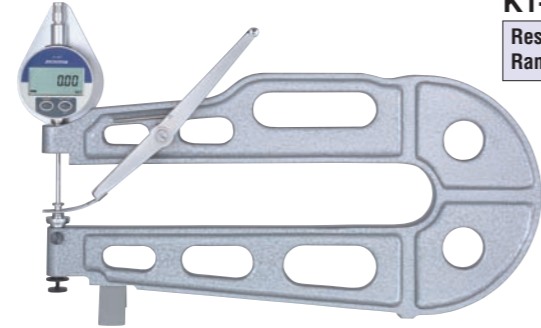

K1-257
Resolution: 0.01mm
Range: 20mm

Dimensions JA-205 · JA-257

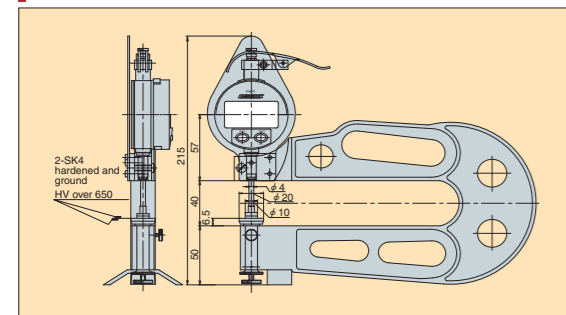

Dimensions K1-257

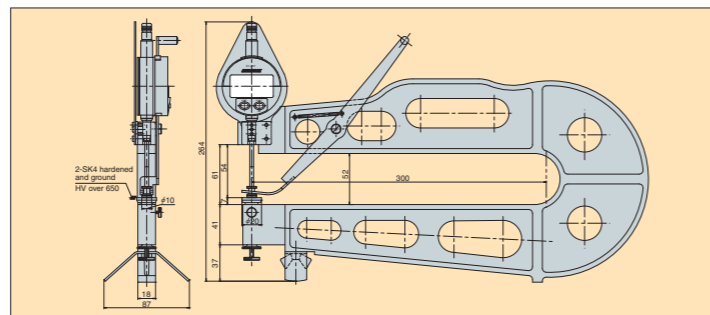

Specifications

Model	Resolution (mm)	Accuracy (excluding quantized error) (mm)	Gauge type	Measuring range (mm)	Measuring depth (mm)	Measuring force (N)	Contact point diameter (mm)	Contact point parallelism (mm)	Anvil diameter (mm)
JA-205	0.001	±0.01	DG-205	20	150	Less than 1.1	ø10	Less than 0.005	ø20
JA-257	0.01	±0.02	DG-257	20	150	Less than 1.1	ø10	Less than 0.01	ø20
K1-257	0.01	±0.02	DG-257	20	300	Less than 2.0	ø10	Less than 0.01	ø20

Digital Pipe Gauge

P2-257

Resolution: 0.01mm
Range: 15mm

P2-127

Resolution: 0.01mm
Range: 10mm



Dimensions

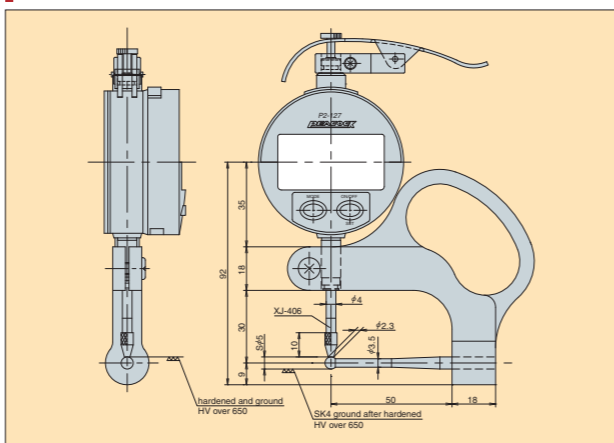

Specifications

Model	Resolution (mm)	Accuracy (excluding quantized error) (mm)	Gauge type	Measuring range (mm)	Measuring depth (mm)	Measuring force (N)	Measuring hole diameter (mm)
P2-257	0.01	±0.02	DG-257	15	50	Less than 1.1	ø5.1
P2-127	0.01	±0.02	DG-127	10	50	Less than 0.95	ø5.1

Applied Digital Gauges

Digital Upright Gauges (0.001mm, 0.01mm)

- Best suited to inspect sizes precision parts or to measure thickness of laboratory specimens.



R1-205

Resolution: 0.001mm
Range: 20mm

R1-257

Resolution: 0.01mm
Range: 20mm

R1-127

Resolution: 0.01mm
Range: 12mm

Dimensions

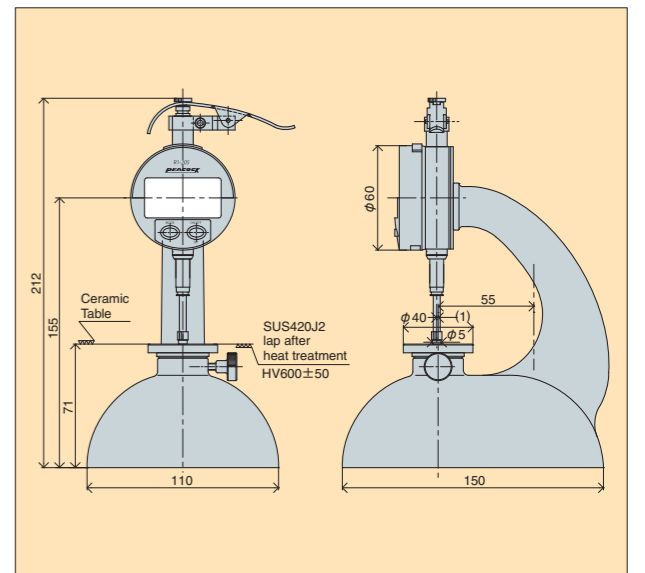

Specifications

Model	Resolution (mm)	Accuracy (excluding quantized error) (mm)	Gauge type	Measuring range (mm)	Measuring force (N)	Measuring depth (mm)	Contact point (mm)	Table diameter (mm)
R1-205	0.001	±0.004	DG-205	20	Less than 1.1	55	ø5	ø40
R1-257	0.01	±0.02	DG-257	20	Less than 1.1	55	ø5	ø40
R1-127	0.01	±0.02	DG-127	12	Less than 0.95	55	ø5	ø40

Modification for contact point (Special order)

Flat type	Replaceable Contact Point	Needle type
<p>Please specify "øD"</p>	<p>Accessories for Dial Gauges Replaceable contact points can be installed.</p>	<p>Please specify dimension of "H" and "øD"</p>

Deep Hole Bore Gauge-EMCC Series

- The EMCC Series can easily measure the inside diameter of deep bore with high accuracy, which has been precision-machined.
- The EMCC Series advances a detector having an automatic alignment mechanism in line with the inside diameter.
- Measurement is possible up to the length of 10M by using an additional extension rod.



EMCC-3

Compatible Counter C-500



Specifications

Model	EMCC-2	EMCC-3	EMCC-4	EMCC-5	EMCC-6		
Measuring range (ID)	35 ~ 60mm	50 ~ 100mm	100 ~ 160mm	160 ~ 250mm	250 ~ 400mm		
Measuring depth	70mm ~ 10M	90mm ~ 10M	120mm ~ 10M	130mm ~ 10M	150mm ~ 10M		
Number of feeler	Intervals 5mm×6	Intervals 5mm×11	Intervals 10mm×7	Intervals 10mm×10	Intervals 10mm×16		
Thickness of washers	1,2,3mm each		1,2,3,4mm each				
Contact Point	L=33mm (flat type)		L=44mm (flat type)				
Contact point's travel and measuring force	1.4mm / less than 2.0N						
Extension rods	EMCC-L (1 meter rod×10 rods = 10 meters)sold separately						
Compatible linear gauges	● When Resolution is 10μm, use D-5B ● When Resolution is 1μm, use D-5SB						
Compatible counters	● C-500						
Operations	● Test completes only after receiving reference from a master and inserting the micrometer head through a workpiece. ● Automatic centering mechanism requires no manual "shaking" to center up the micrometer head.						
Functions	● Workpiece has to be horizontally level (No test can be performed with the workpiece perpendicular).						
Dimensions (mm)	A	70	71	77	77	77	
	B	20	30	40	45	50	
	C	30	40	55	60	70	
	D	62	82	115	125	140	
	E	15	20	38	58	88	
	F	22	30	50	70	100	
	G	MIN	35	50	100	160	250
		MAX	60	100	160	250	400

※ To make up a complete working unit, it requires an EMCC (2-6), an EMCC-L (extension rod set), a linear gauge and a counter.

Dimensions

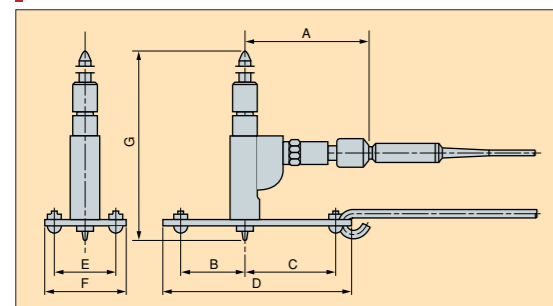

Gauge Sensor

Model	D-5B	D-5SB
Resolution	0.01mm	0.001mm
Accuracy	0.01mm	0.002mm
Cable length	10 meters	
Screw pitch of Contact Point	M2.5 × 0.45	
Measuring force	Less than 0.5N	
Remarks	Specifications are according to D-5S	

Features

- **The inside diameter of extremely deep can be measured. (Max. 10M)**
The inside diameter of the deep hole that was not able to be measured so far can be easily measured with our development of automatic brought to a center position and added to extension rods to the Linear Gauge..
- **High performance**
It is possible to measure with high performance as our Linear gauge is used for the detector. (0.01mm, 0.001mm)
- **Easy operation**
Due to our development of our automatic brought to a center position, the measurement operation is easier than a general inside diameter measuring instruments as only insert the cylinder detector in the hole of measurement work-piece.
- **Efficient measurement**
Since the easy operation, it is efficient of the measurement for an inspection of the mass production.
- **Excellent indication stability**
It is necessary to shakes the general cylinder gauge for reads a minimum measurement. However, our EMCC can get the excellent stability of the indication as only insert the detector to the hole of measurement work-piece.
- **Low measuring force**
The work-piece is not so damaged as the measuring force of contact point is 2.0N compared with a general cylinder gauges (5.0~6.0N)
- **Data record**
Digital counter have the RS-232C output so that the measuring data can be processed.

The main usage

Internal diameter measurement of extremely deep hole
Hydraulic Cylinder, Air Cylinder, Cylinder of Extruder, High accuracy Pipe, Mold for Pipe etc.

Extension Rods (1M x 10 pcs) as Optional

To insert or pull-out the detector to the hole of measurement work-piece.

Display Counter

Data displayed by Digitally
Selection of a resolution (0.01mm or 0.001mm)

*see page 145 for more detailed information

Model No.	C-500
Range of Display	At the 0.01mm Selection -9999.99~00.00~9999.99
	At the 0.001mm Selection -999.999~0.000~999.999
Resolution	0.001mm / 0.01mm Selectable
Quantized error	±1 count
Data output	RS-232C
Power supply	AC100V~AC240 · less 9VA
Weight	950g

Measurement figure

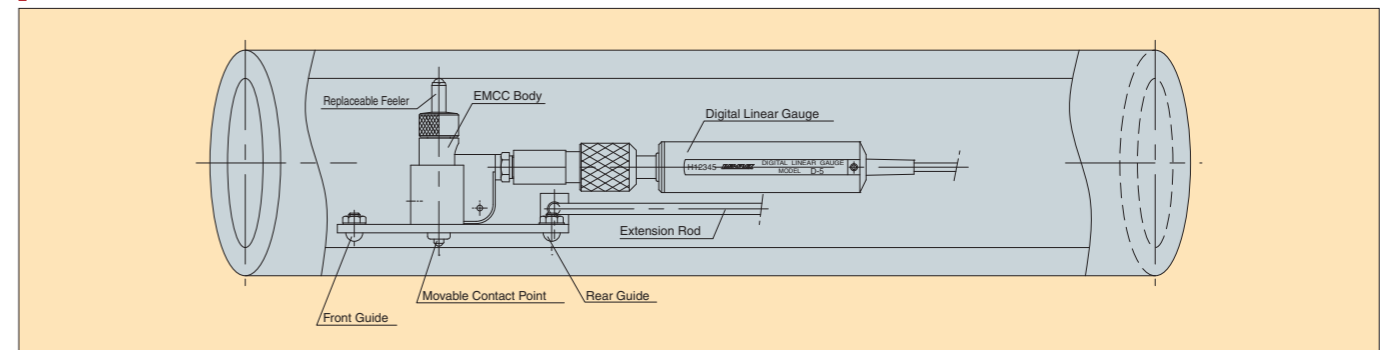

Combination example



- Linear Gauge No. D-50S
- Digital Counter No. C-700
- Gauge Stand No. PDS-2

※As for more detailed specifications, refer to page 117, 140 and 145.

Technical Glossary

● What is a "Linear Scale"?

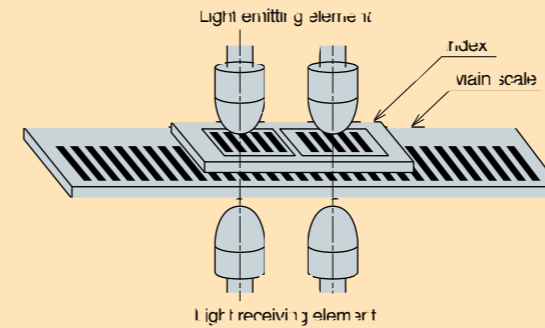

As illustrated on the left, an optical glass with vacuum deposition of chrome metal (opaque) at a constant pitch is called a linear scale (scale pitch of 20, 16 or 8μm is used)

The opposite scale to this linear scale is called an Index scale. This is designed to sense two phases of signal mutually having 90° degree phase difference for the purpose of discriminating shift direction of the scale.

The light intensity of the light emitter is detected by the photo receptor located directly opposite.

When a linear scale moves, the photo receptor will receive variation of light and shade.

Linear displacement can be measured by counting these electric signals with a counter. (Counting them by 20μm pitch will give 5μm display resolution and electrically dividing the wave results in 1μm display resolution)

● About "Quantizing error"

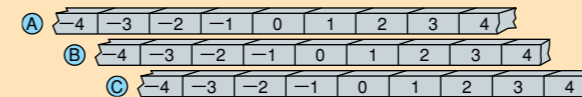

In quantization (displacement under the minimum display digit shall be defined as 0 or 1), the point "0" has a width similar to the other numeric values; including "0" closest to "1" and also "0" closest to "-1". Therefore, ±1 count error is generated in the minimum display digit. (The value "0" is displayed after setting a linear gauge and then pressing the "Reset" switch.)

The counter "C-5" resolves the quantizing error in 1/100mm digit by setting the display value of the minimum digit to 5μm display. (If you need to resolve the quantizing error in 1/1000mm display type, please use "C-5SS" with 0.0005mm display.)

- A's zero reference was taken at the B's zero closer to -1.
- C's zero reference was taken at the B's zero closer to +1

● Difference between "Measuring Force" and "Measuring Pressure"

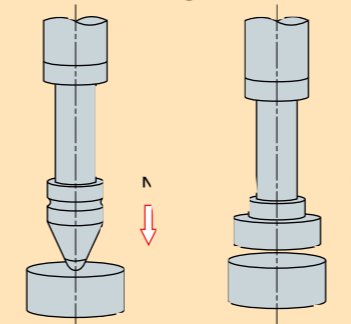

■ "Measuring Force"

Pressure of a contact point pressing a workpiece is defined as measuring force. Generally, as the spindle back spring is integrated in a gauge, it indicates the state in which the spindle is possibly pressed into a workpiece. (A weighted gauge can get a constant measuring force at any position) Unit.....N(newton)

■ "Measuring Pressure"

It is the value indicating the force of contact point pressing a workpiece in a unit area. (measuring force per unit layer). After specifying the area (diameter) of contact point to be in contact to a workpiece, the measuring force to be pressed in a unit area is defined as measuring pressure. (When it is necessary to specify measuring pressure, a type with an attached weight is usually used since there is no change in the measuring force, even in the stroke of a spindle.) Unit 1Pa = 0.101972 × 10⁵kgf/mm²

● Expression of accuracy

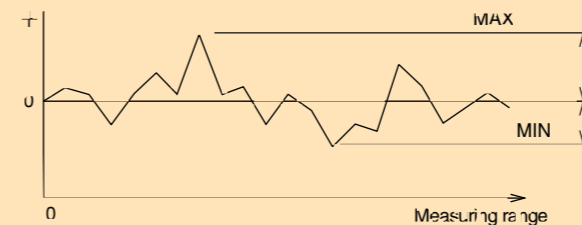

Accuracy is the difference between the zero reference point and the greatest deviation across the entire measurement range. +Xμm represents the combined + error Xμm and - error Xμm allowed.

Xμm represents an absolute value: if an error of Xμm occurs in +, - error is not allowed (0μm). Accordingly, if an error of Xμm occurs in -, + error is not allowed (0μm). Thus, Xμm error allowance is harder to achieve than +Xμm error allowance. (In this catalog, we use absolute value, Xμm.)

■ Accuracy of Lever-type Linear Gauges (DL-2, DL-2S)

These DL-2 and DL-2S linear gauges are used in applications very similar to lever-type dial indicators. Their accuracy is represented every 0.5mm interval, not over the entire measurement range.
 0~0.5mm 0.5mm~1.0mm
 1.0~1.5mm 1.5~2.0mm
 The entire measurement range is divided into 4 sections. The largest deviation among these 4 sections will determine accuracy.

● Methods of Supporting Stem

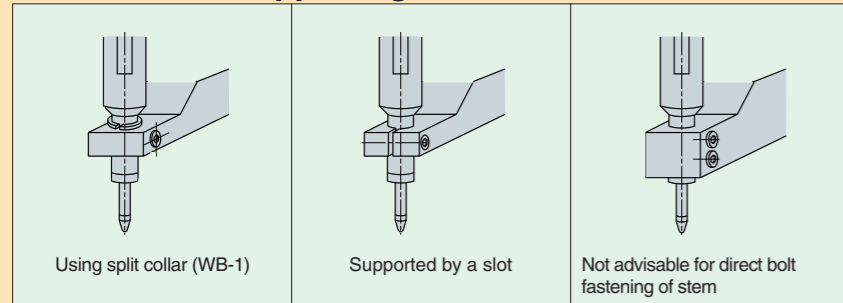

There are 2 methods for mounting of a linear gauge, namely by 'stem' or "lug". As illustrated on the left, please secure a stem by a split collar or a slot. (If a stem is secured directly by a screw or screws, the spindle may not move smoothly.) Please use split collar WB-1 designed exclusively for ϕ 8mm stem.

● Positioning Lever-type Linear Gauges

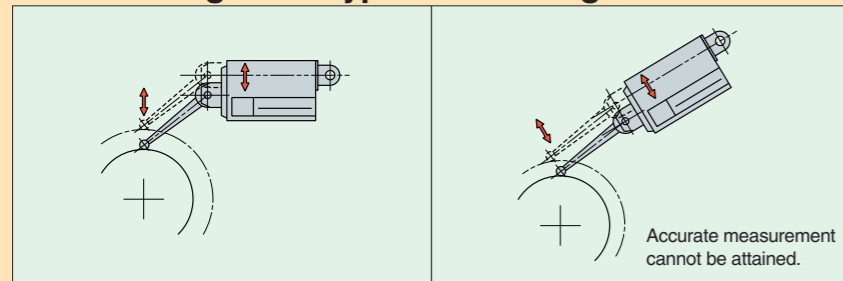

As illustrated on the left for a lever type linear gauge, the lever moves linearly, different from a lever type dial indicator. Lever type dial indicator can be freely set on a work-piece because of its arc movement. However, lever type linear gauge should be set on a workpiece extensively at right angle. (Since no deviation from arc is generated, the measuring range is set to 2mm wide.)

● About Polarity Conversion

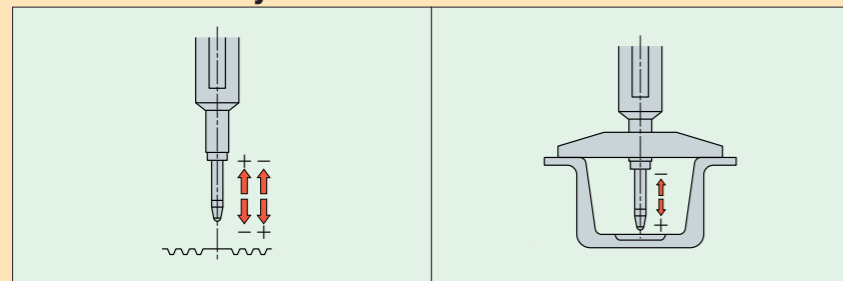

When you need the reversed value to be read, for example, in case of depth measurement, "-" count should be set in the direction of pulling up of a spindle. In standard counters, you will find this switch on the back panel.

● Reset/Preset

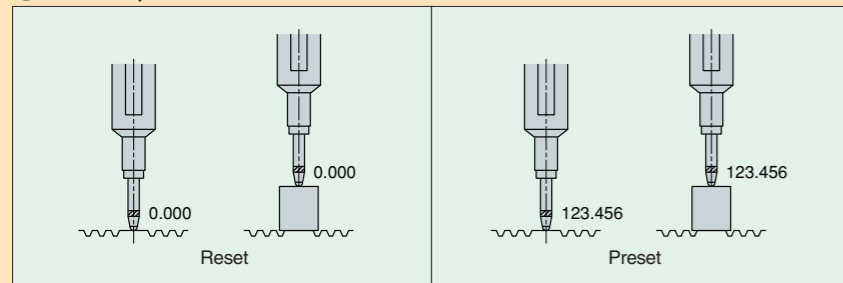

Linear gauges can be reset to zero at any position in the measuring range. Counters with preset function can be set a desired value at a desired position. Since values are displayed based on the preset value as a reference, it is suitable for managing the measured values by their absolute values.

● Protection Classifications

Example of protection classes based on IEC529(DIN40050)(First=protection classes for solid 0 to 6, Second=protection classes for liquid 0 to 8)

IP-54 Protection Class

Type	Class	Specifications
Represents human body, protection and protection against foreign objects	5: Protection against dust	Provides protection against dust.
Represents protection against water	4: Splash proof type	No harmful result caused by water splashed from all directions (water splashproof).

IP-66 Protection Class

Type	Class	Specifications
Represents human body, protection and protection against foreign object	6: Anti-dust seal type	Provides complete anti-dust protection against dust invasion.
Represents protection against water	6: Full waterproof type	Protection that eliminates any water invasion including direct water jet from all directions (completely waterproof).

SECTION
12



Parts Drawings

- New Pic Test
- Pic Test
- Dial Gauge
- Dial Thickness Gauge
- Dial Lens Gauge
- Cylinder Gauge

Parts Drawings

PCN series

New Pic Test PCN-1A

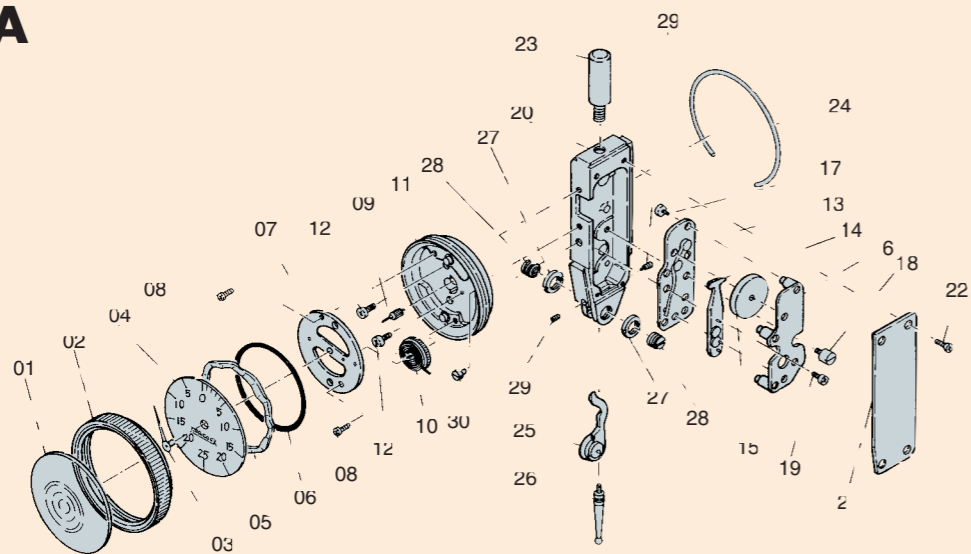

- | | | | |
|--------------------------------|------------------------------------------|----------------------------------------|------------------------------------|
| 01 Crystal | 09 10Z Pinion | 16**Upper Plate Assy | 23 Stem |
| 02 Bezel | 10 60Z Idle Gear Assy (with Hair Spring) | 17**Set Screw for Metal Column (S-179) | 24 Wire Spring |
| 03 Pointer | 11**Base Metal (with Spindle Jewel) | 18**Stopper Screw (S-092) | 25 Lever with Bearing |
| 04 Dial | 12**Set Screw for Base Metal (S-171) | 19**Set Screw for Lower Plate (S-045) | 26 Contact Point (XN1A-2) |
| 05 Plate Spring | 13**Lower Plate Assy | 20**Main Body | 27 Nut for Pivot |
| 06 O-Ring | 14 Sector Gear Assy | 21**Side Cover | 28 Pivot (with Miniature Bearings) |
| 07 Metal (with Jewel) | 15 Crown Gear (with 26Z Pinion) | 22 Set Scerw for Side Cover (S-185) | 29 Adjustment Screw (S-014) |
| 08 Set Screw for Metal (S-132) | | | 30 Hair Spring Column |

**mark are not for sell.

Parts Drawings

PCN series

New Pic Test PCN-1L

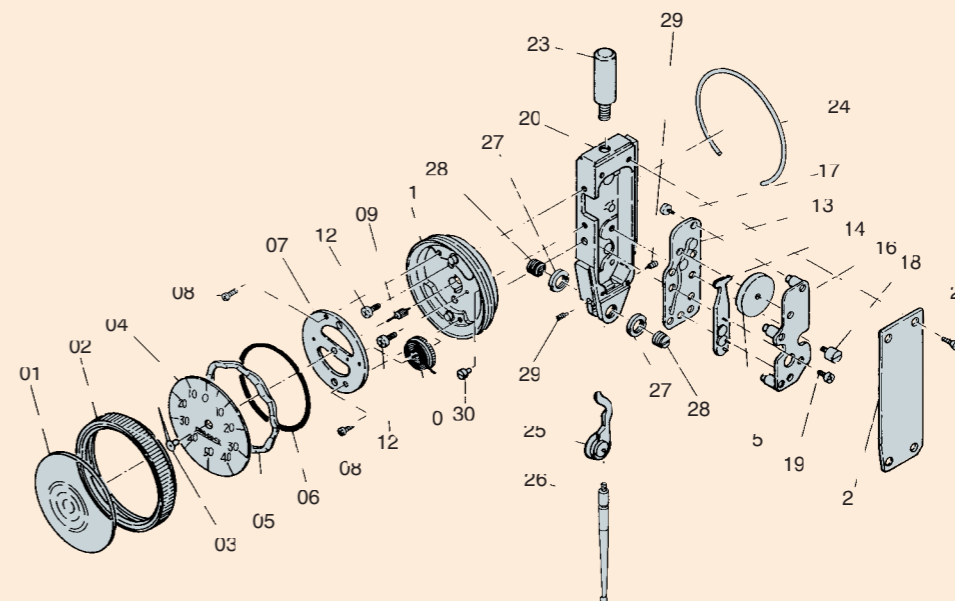

- | | | | |
|--------------------------------|------------------------------------------|----------------------------------------|------------------------------------|
| 01 Crystal | 09 10Z Pinion | 16**Upper Plate Assy | 23 Stem |
| 02 Bezel | 10 60Z Idle Gear Assy (with Hair Spring) | 17**Set Screw for Metal Column (S-179) | 24 Wire Spring |
| 03 Pointer | 11**Base Metal (with Jewel) | 18**Stopper Screw (S-092) | 25 Lever with Bearing |
| 04 Dial | 12**Set Screw for Base Metal (S-171) | 19**Set Screw for Lower Plate (S-045) | 26 Contact Point (XN1L-2) |
| 05 Plate Spring | 13**Lower Plate Assy | 20**Main Body | 27 Nut for Pivot |
| 06 O-Ring | 14 Sector Gear Assy | 21**Side Cover | 28 Pivot (with Miniature Bearings) |
| 07 Metal (with Jewel) | 15 Crown Gear (with 26Z Pinion) | 22 Set Scerw for Side Cover (S-185) | 29 Adjustment Screw (S-014) |
| 08 Set Screw for Metal (S-132) | | | 30 Hair Spring Column |

**mark are not for sell.

New Pic Test PCN-1B

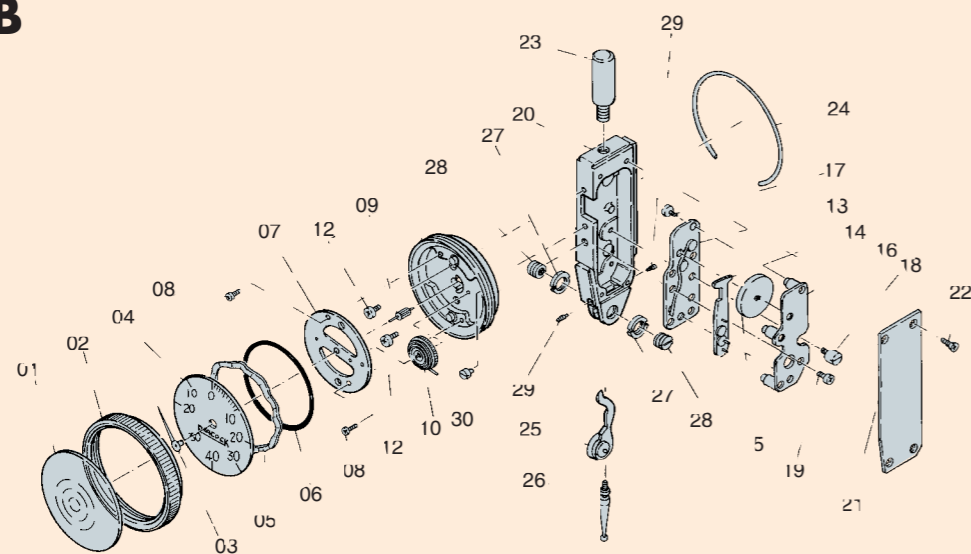

- | | | | |
|--------------------------------|----------------------------------------------|----------------------------------------|------------------------------------|
| 01 Crystal | 09 10Z Pinion | 16**Upper Plate Assembly | 23 Stem |
| 02 Bezel | 10 60Z Idle Gear Assembly (with Hair Spring) | 17**Set Screw for Metal Column (S-179) | 24 Wire Spring |
| 03 Pointer | 11**Base Metal (with Spindle Jewel) | 18**Stopper Screw (S-092) | 25 Lever with Bearing |
| 04 Dial | 12**Set Screw for Base Metal (S-171) | 19**Set Screw for Lower Plate (S-045) | 26 Contact Point (XN1B-2) |
| 05 Plate Spring | 13**Lower Plate Assembly | 20**Main Body | 27 Nut for Pivot |
| 06 O-Ring | 14 Sector Gear Assembly | 21**Side Cover | 28 Pivot (with Miniature Bearings) |
| 07 Metal (with Jewel) | 15 Crown Gear (with 38Z Pinion) | 22 Set Scerw for Side Cover (S-185) | 29 Adjustment Screw (S-014) |
| 08 Set Screw for Metal (S-132) | | | 30 Hair Spring Column |

**mark are not for sell.

New Pic Test PCN-2

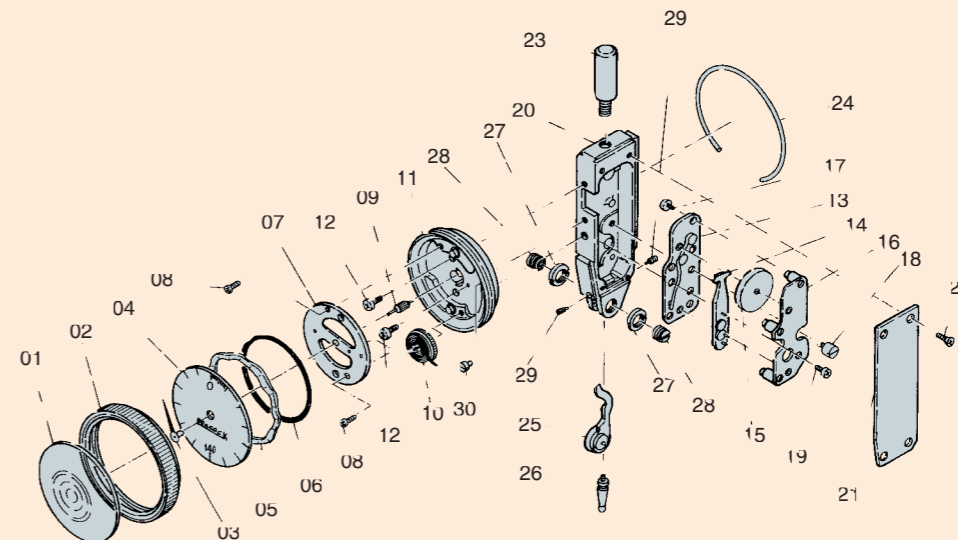

- | | | | |
|--------------------------------|------------------------------------------|----------------------------------------|------------------------------------|
| 01 Crystal | 09 10Z Pinion | 16**Upper Plate Assy | 23 Stem |
| 02 Bezel | 10 60Z Idle Gear Assy (with Hair Spring) | 17**Set Screw for Metal Column (S-179) | 24 Wire Spring |
| 03 Pointer | 11**Base Metal (with Jewel) | 18**Stopper Screw (S-092) | 25 Lever with Bearing |
| 04 Dial | 12**Set Screw for Base Metal (S-171) | 19**Set Screw for Lower Plate (S-045) | 26 Contact Point (XN2-2) |
| 05 Plate Spring | 13**Lower Plate Assy | 20**Main Body | 27 Nut for Pivot |
| 06 O-Ring | 14 Sector Gear Assy | 21**Side Cover | 28 Pivot (with Miniature Bearings) |
| 07 Metal (with Jewel) | 15 Crown Gear (with 18Z Pinion) | 22 Set Scerw for Side Cover (S-185) | 29 Adjustment Screw (S-014) |
| 08 Set Screw for Metal (S-132) | | | 30 Hair Spring Column |

**mark are not for sell.

Parts Drawings

PCN series PC series

New Pic Test PCN-S

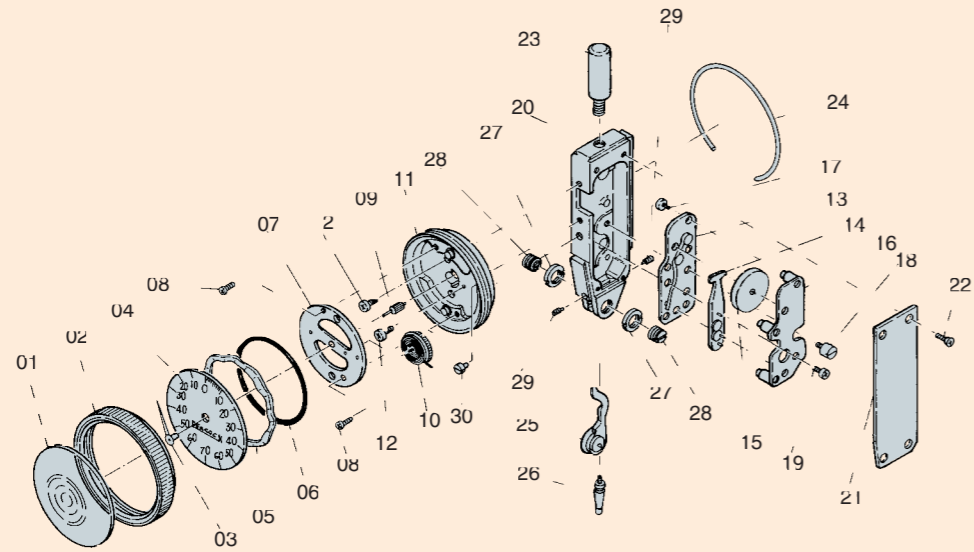

- | | | | |
|--------------------------------|----------------------------------------------|----------------------------------------|------------------------------------|
| 01 Crystal | 09 10Z Pinion | 16**Upper Plate Assy | 23 Stem |
| 02 Bezel | 10 60Z Idle Gear Assembly (with Hair Spring) | 17**Set Screw for Metal Column (S-179) | 24 Wire Spring |
| 03 Pointer | 11**Base Metal (with Jewel) | 18**Stopper Screw (S-092) | 25 Lever with Bearing |
| 04 Dial | 12**Set Screw for Base Metal (S-171) | 19**Set Screw for Lower Plate (S-045) | 26 Contact Point (XNS-2) |
| 05 Plate Spring | 13**Lower Plate Assy | 20**Main Body | 27 Nut for Pivot |
| 06 O-Ring | 14 Sector Gear Assy | 21**Side Cover | 28 Pivot (with Miniature Bearings) |
| 07 Metal (with Jewel) | 15 Crown Gear (with 14Z Pinion) | 22 Set Screw for Side Cover (S-185) | 29 Adjustment Screw (S-014) |
| 08 Set Screw for Metal (S-132) | | | 30 Hair Spring Column |

**mark are not for sell.

Parts Drawings

PC series

Pic Test PC-1B

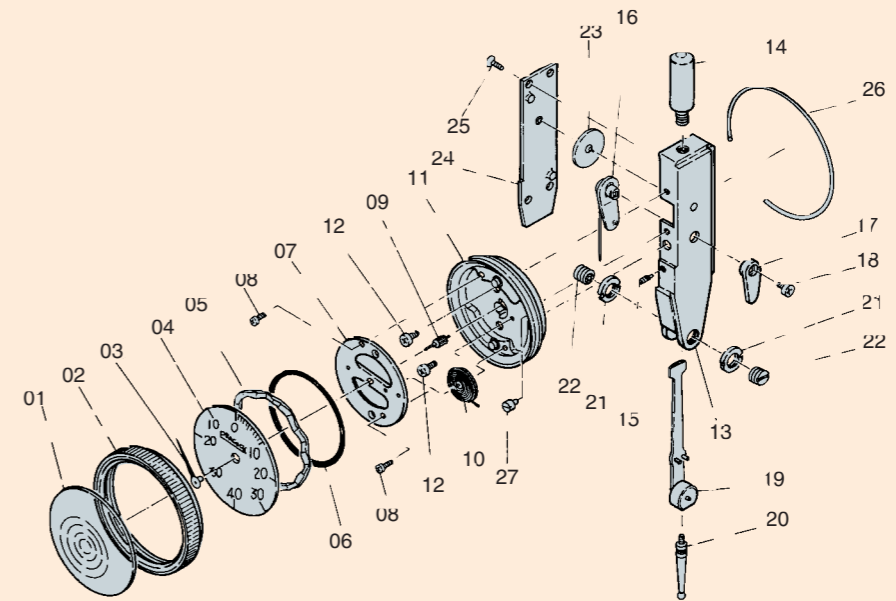

- | | | | |
|--------------------------------|------------------------------------------|-----------------------------------------|--------------------------------------|
| 01 Crystal | 09 10Z Pinion | 16**Clutch Lever Assy | 23 Crown Gear Assy (with 21Z Pinion) |
| 02 Bezel | 10 60Z Idle Gear Assy (with Hair Spring) | 17 Clutch Lever | 24**Side Cover |
| 03 Pointer | 11**Base Metal (with Jewel) | 18 Set Screw for Clutch Lever (S-179) | 25 Set Screw for Side Cover (S-163) |
| 04 Dial | 12**Set Screw for Base Metal (S-171) | 19 Sector Gear Assy | 26 Wire Spring |
| 05 Plate Spring | 13**Main Body | 20 Contact Point (XP1B-2) | 27 Hair Spring Column |
| 06 O-Ring | 14 Stem | 21 Nut for Pivot | |
| 07 Metal (with Jewel) | 15**Stopper Screw (S-164) | 22 Pivot Assy (with Miniature Bearings) | |
| 08 Set Screw for Metal (S-132) | | | |

**mark are not for sell.

Pic Test PC-1A

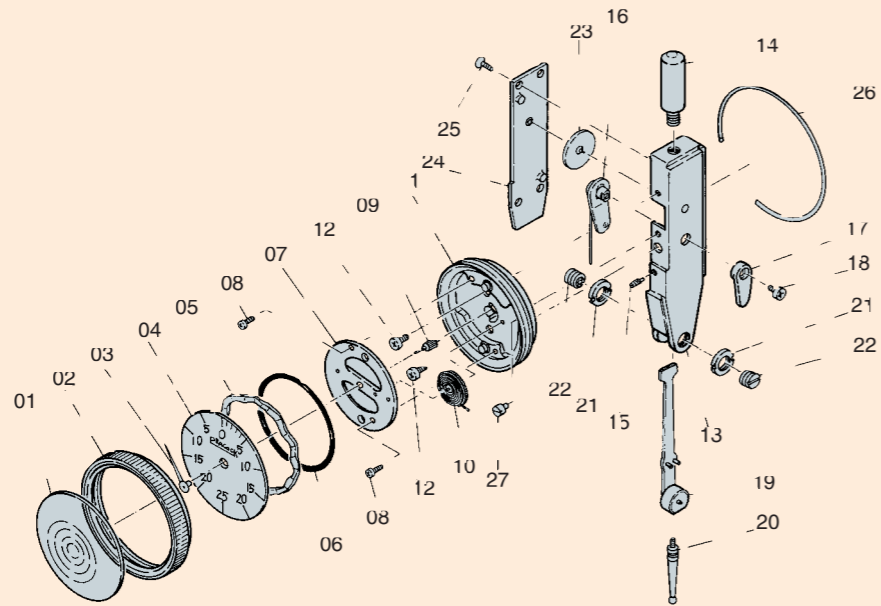

- | | | | |
|--------------------------------|------------------------------------------|-----------------------------------------|--------------------------------------|
| 01 Crystal | 09 10Z Pinion | 16**Clutch Lever Assy | 23 Crown Gear Assy (with 14Z Pinion) |
| 02 Bezel | 10 60Z Idle Gear Assy (with Hair Spring) | 17 Clutch Lever | 24**Side Cover |
| 03 Pointer | 11**Base Metal (with Jewel) | 18 Set Screw for Clutch Lever (S-179) | 25 Set Screw for Side Cover (S-163) |
| 04 Dial | 12**Set Screw for Base Metal (S-171) | 19 Sector Gear Assy | 26 Wire Spring |
| 05 Plate Spring | 13**Main Body | 20 Contact Point (XP1A-2) | 27 Hair Spring Column |
| 06 O-Ring | 14 Stem | 21 Nut for Pivot | |
| 07 Metal (with Jewel) | 15**Stopper Screw (S-164) | 22 Pivot Assy (with Miniature Bearings) | |
| 08 Set Screw for Metal (S-132) | | | |

**mark are not for sell.

Pic Test PC-1L

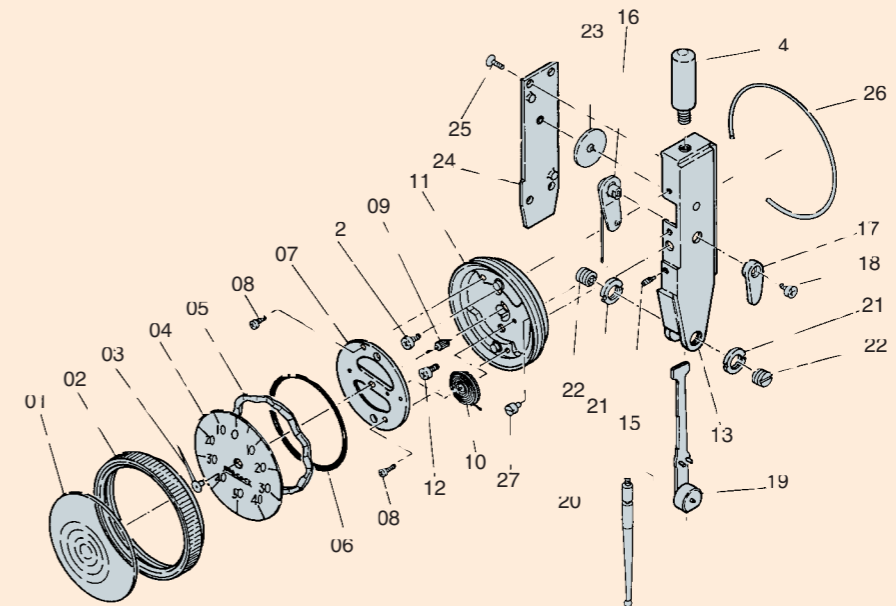

- | | | | |
|--------------------------------|------------------------------------------|-----------------------------------------|--------------------------------------|
| 01 Crystal | 09 10Z Pinion | 16**Clutch Lever Assy | 23 Crown Gear Assy (with 14Z Pinion) |
| 02 Bezel | 10 60Z Idle Gear Assy (with Hair Spring) | 17 Clutch Lever | 24**Side Cover |
| 03 Pointer | 11**Base Metal (with Jewel) | 18 Set Screw for Clutch Lever (S-179) | 25 Set Screw for Side Cover (S-163) |
| 04 Dial | 12**Set Screw for Base Metal (S-171) | 19 Sector Gear Assy | 26 Wire Spring |
| 05 Plate Spring | 13**Main Body | 20 Contact Point (XP1L-2) | 27 Hair Spring Column |
| 06 O-Ring | 14 Stem | 21 Nut for Pivot | |
| 07 Metal (with Jewel) | 15**Stopper Screw (S-164) | 22 Pivot Assy (with Miniature Bearings) | |
| 08 Set Screw for Metal (S-132) | | | |

**mark are not for sell.

Parts Drawings

Dial Gauges

Dial Gauge
107

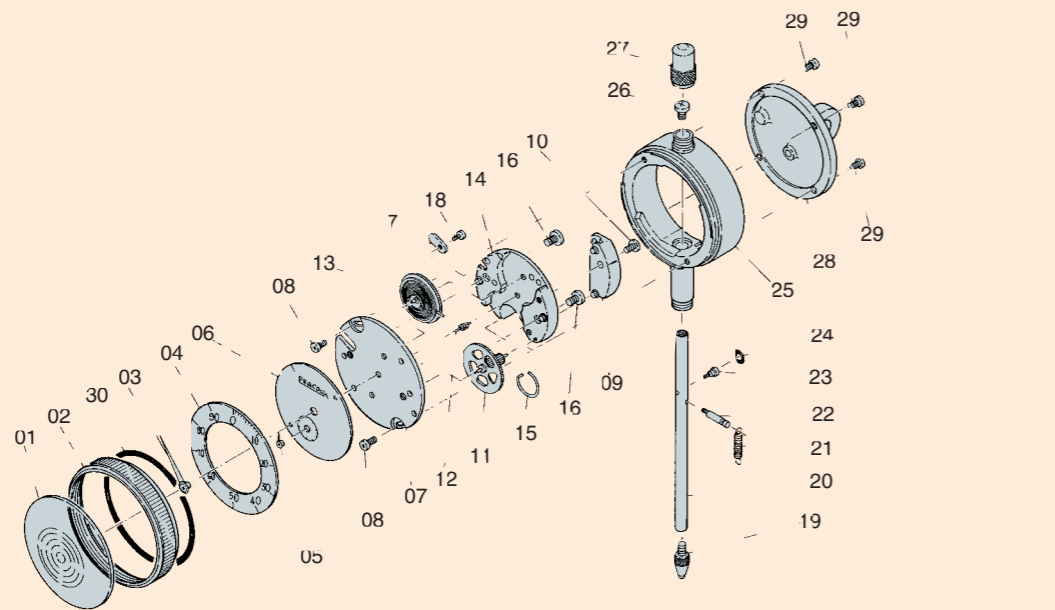

- | | | | |
|--------------------------------------|------------------------------------------|---------------------------------------------|-----------------------------------|
| 01 Crystal | 09**Guide Metal | 16**Set Screw for Upper Metal (S-010) | 24 Shock-Proof Rubber |
| 02 Bezel | 10**Set Screw for Guide Metal | 17 Claw | 25**Inner Frame |
| 03 Pointer | 11 120Z Main Gear Assy (with 16Z Pinion) | 18 Set Screw for Claw (S-009) | 26 Screw (S-010) |
| 04 Outer Dial | 12 12Z Pinion | 19 Contact Point (X-1) | 27 Cap |
| 05 Hand | 13 120Z Idle Gear Assy | 20 Spindle | 28 Lug Back (GB-1A) |
| 06 Inner Dial | 14**Upper Metal (with Jewel) | 21 Coil Spring | 29 Set Screw for Lug Back (S-156) |
| 07**Base Metal (with Jewel) | 15 Wire Spring for Bezel | 22 Guide Knock | 30 O-Ring |
| 08**Set Screw for Base Metal (S-217) | | 23 Set Screw for Shock-Proof Rubber (S-219) | |

**mark are not for sell.

Dial Gauge
57

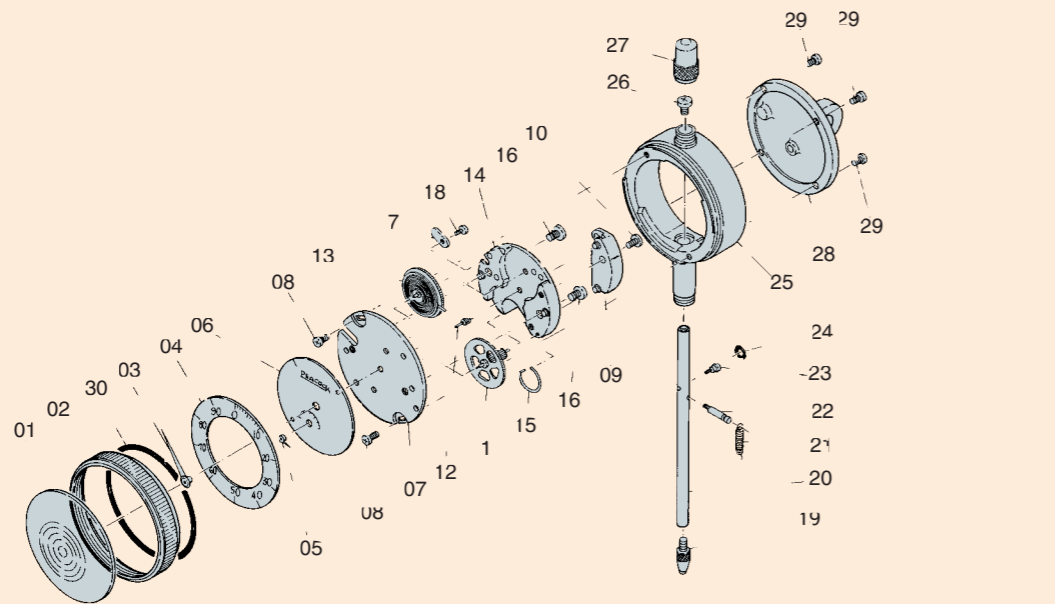

- | | | | |
|--------------------------------------|---------------------------------------|---------------------------------------------|-----------------------------------|
| 01 Crystal | 09**Guide Metal | 17 Claw | 24 Shock-Proof Rubber |
| 02 Bezel | 10**Set Screw for Guide Metal (S-012) | 18 Set Screw for Claw (S-009) | 25**Inner Frame |
| 03 Pointer | 11 120Z Main Gear (with 16Z Pinion) | 19 Contact Point (X-1) | 26 Screw (S-010) |
| 04 Outer Dial | 12 12Z Pinion | 20 Spindle | 27 Cap |
| 05 Hand | 13 120Z Idle Gear Assy | 21 Coil Spring | 28 Lug Back (GB-1A) |
| 06 Inner Dial | 14**Upper Metal (with Spindle Jewel) | 22 Guide Knock | 29 Set Screw for Lug Back (S-156) |
| 07**Base Metal (with Jewel) | 15 Wire Spring for Bezel | 23 Set Screw for Shock-Proof Rubber (S-219) | 30 O-Ring |
| 08**Set Screw for Base Metal (S-217) | 16 Set Screw for Upper Metal (S-010) | | |

**mark are not for sell.

Parts Drawings

Dial Gauges

Dial Gauge
5B

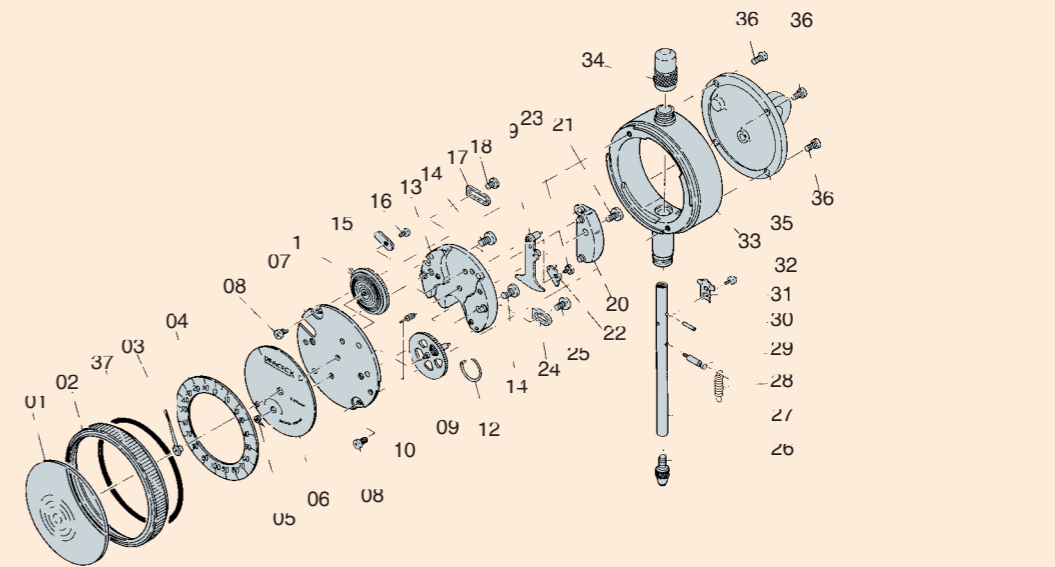

- | | | | |
|------------------------------------------|-------------------------------------------|-----------------------------------------|------------------------------------------|
| 01 Crystal | 11 120Z Idle Gear Assy (with Hair Spring) | Gear Shaft' Eccentric Shaft) | 29 Guide Knock |
| 02 Bezel | 12 Wire Spring for Bezel | 20**Guide Metal | 30**Bracket Knock (A) |
| 03 Pointer | 13**Upper Metal (with Spindle Jewel) | 21**Set Screw for Guide Metal (S-012) | 31 Spindle Stopper |
| 04 Outer Dial | 14 Set Screw for Upper Metal (S-010) | 22**Bracket (with Bracket Knock A) | 32 Set Screw for Spindle Stopper (S-001) |
| 05 Hand | 15 Claw | 23**Set Screw for Bracket (S-006) | 33**Inner Frame |
| 06 Inner Dial | 16 Set Screw for Claw (S-009) | 24 Adjust Stopper | 34 Cap |
| 07**Base Metal (with Jewel) | 17**Adjust Stopper (B) | 25 Set Screw for Adjust Stopper (S-012) | 35 Lug Back (GB-1A) |
| 08**Set Screw for Base Metal (S-217) | 18**Set Screw for Adjust Stopper (S-004) | 26 Contact Point (X-1) | 36 Set Screw for Lug Back (S-156) |
| 09 120Z Main Gear Assy (with 16Z Pinion) | 19 Sector Gear Assy (with Sector | 27 Spindle | 37 O-Ring |
| 10 12Z Pinion | | 28 Coil Spring | |

**mark are not for sell.

Dial Gauge
207

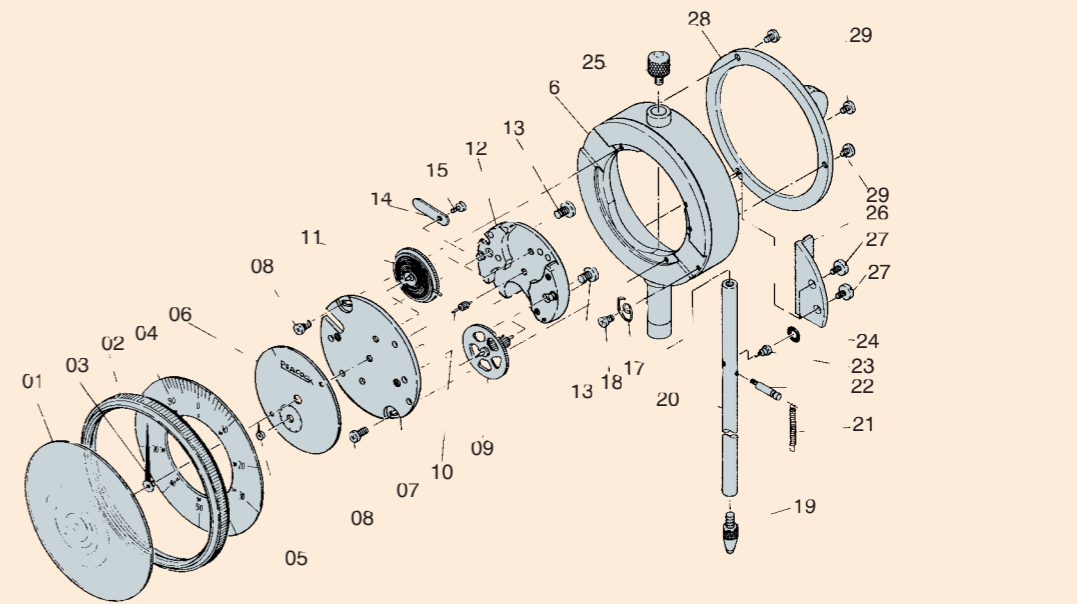

- | | | | |
|--------------------------------------|---------------------------------------|------------------------------------------------|---------------------------------------|
| 01 Crystal | 09 120Z Main Gear (with 16Z Pinion) | 17 Wire Spring for Bezel (S-219) | 24 Shock-Proof Rubber |
| 02 Bezel | 10 12Z Pinion | 18 Set Screw for Wire Spring for Bezel (S-130) | 25 Top Screw |
| 03 Pointer | 11 120Z Idle Gear (with Hair Spring) | 19 Contact Point (X-1) | 26**Guide Metal |
| 04 Outer Dial | 12**Upper Metal (with Spindle Jewel) | 20 Spindle | 27**Set Screw for Guide Metal (S-012) |
| 05 Hand | 13**Set Screw for Upper Metal (S-010) | 21 Coil Spring | 28 Lug Back (GB-125) |
| 06 Inner Dial | 14 Claw | 22 Guide Knock | 29 Set Screw for Lug Back (S-156) |
| 07**Base Metal (with Jewel) | 15 Set Screw for Claw (S-009) | 23 Set Screw for Shock-Proof Rubber | |
| 08**Set Screw for Base Metal (S-217) | 16**Inner Frame | | |

**mark are not for sell.

Parts Drawings

Dial Gauge Dial Thickness Gauge

Dial Gauge 47

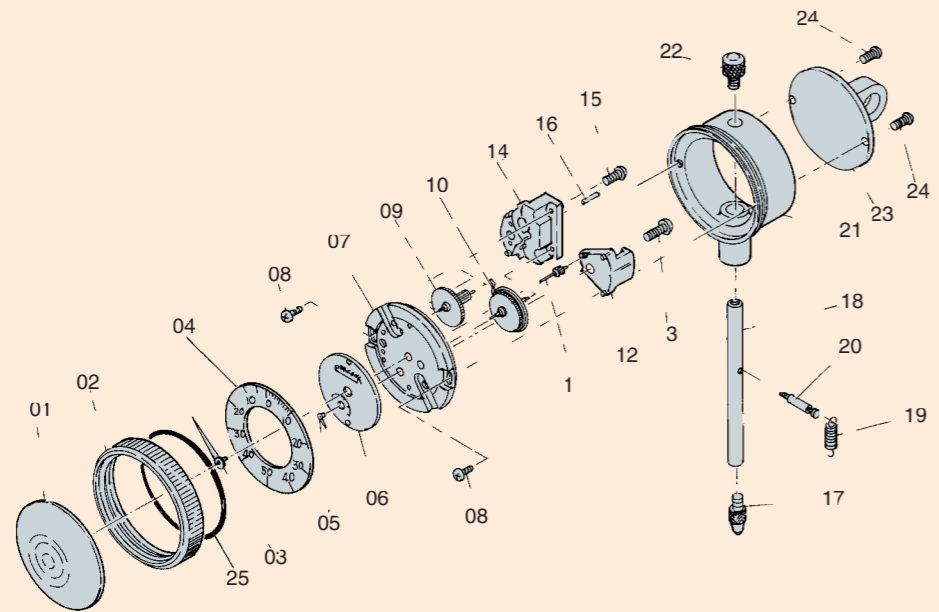

- | | | | |
|----------------------------|---------------------------------------|---------------------------------------|-----------------------------------|
| 01 Crystal | 08*Set Screw for Base Metal (S-009) | 15*Set Screw for Square Metal (S-156) | 21*Inner Frame |
| 02 Bezel | 09 70Z Main Gear (with 14Z Pinion) | 16 Knock for Hair Spring | 22 Top Screw |
| 03 Pointer | 10 70Z Idle Gear Assy | 17 Contact Point (X-107) | 23 Lug Back (GB-147) |
| 04 Outer Dial | 11 10Z Pinion | 18 Spindle | 24 Set Screw for Lug Back (S-005) |
| 05 Hand | 12*Center Metal (with Jewel) | 19 Coil Spring | 25 O-Ring |
| 06 Inner Dial | 13*Set Screw for Center Metal (S-165) | 20 Guide Knock | |
| 07*Base Metal (with Jewel) | 14*Square Metal (with Jewel) | | |

*mark are not for sell.

Parts Drawings

Dial Thickness Gauge Dial Lens Gauge

Dial Thickness Gauge H

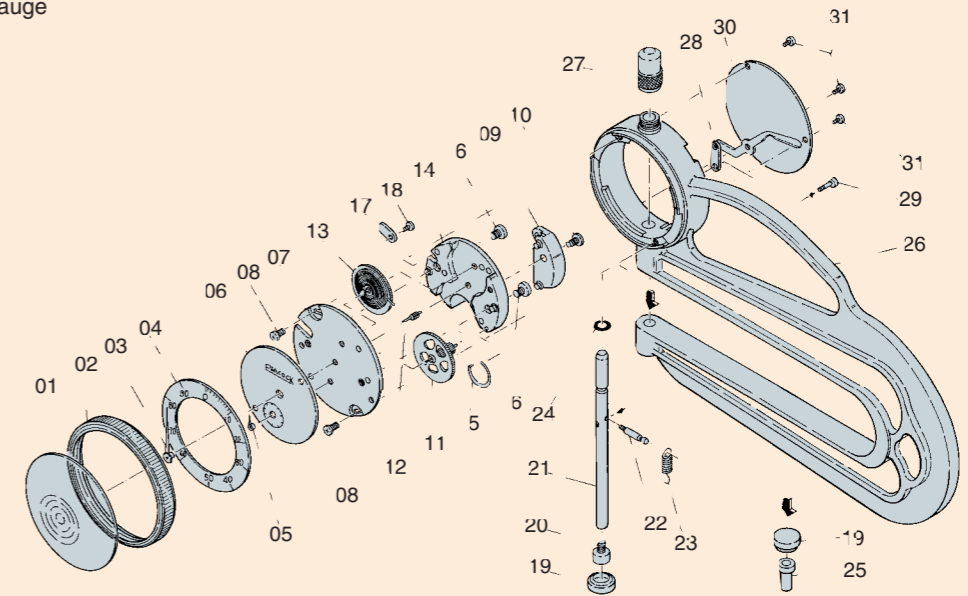

- | | | | |
|--------------------------------|--------------------------------------|-------------------------------|-----------------------------------|
| 01 Crystal | 09*Guide Metal | 17*Claw | 25 Anvil base |
| 02 Bezel | 10*Set Screw for Guide Metal (S-012) | 18*Set Screw for Claw (S-009) | 26*Frame |
| 03 Pointer | 11*120Z Main Gear (with 16Z Pinion) | 19 Anvil | 27*Cap |
| 04 Outer Dial | 12*12Z Pinion | 20 Contact Point set | 28 Lever (with Lift Knock device) |
| 05 Hand | 13*120Z Idle Gear (with Hair Spring) | 21 Spindle | 29 Set Screw for Lift (S-064) |
| 06 Inner Dial | 14*Upper Metal (with Spindle Jewel) | 22*Guide Knock | 30 Back |
| 07*Base Metal (with Jewel) | 15*Wire Spring for Bezel | 23 Coil Spring | 31 Set Screw for Back (S-128) |
| 08*Set Screw for Metal (S-217) | 16*Set Screw for Upper Metal (S-010) | 24*Shock-Proof Rubber | |

*mark are not for sell.

Dial Thickness Gauge

G

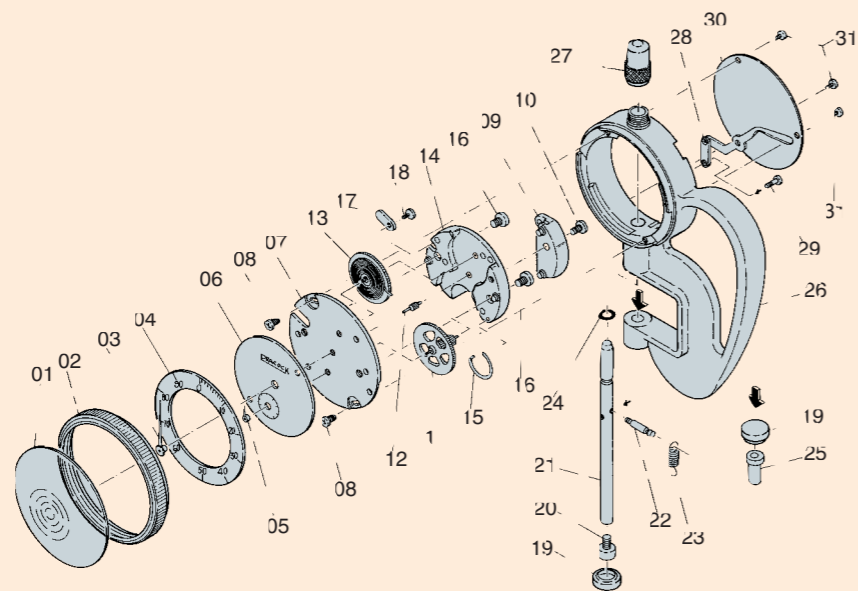

- | | | | |
|-------------------------------------|--------------------------------------|-------------------------------|-----------------------------------|
| 01 Crystal | 09*Guide Metal | 17*Claw | 25 Anvil base |
| 02 Bezel | 10*Set Screw for Guide Metal (S-012) | 18*Set Screw for Claw (S-009) | 26*Frame |
| 03 Pointer | 11*120Z Main Gear (with 16Z Pinion) | 19 Anvil | 27*Cap |
| 04 Outer Dial | 12*12Z Pinion | 20 Contact Point set | 28 Lever (with Lift Knock device) |
| 05 Hand | 13*120Z Idle Gear (with Hair Spring) | 21 Spindle | 29 Set Screw for Lift (S-064) |
| 06 Inner Dial | 14*Upper Metal (with Spindle Jewel) | 22*Guide Knock | 30 Back |
| 07*Base Metal (with Jewel) | 15*Wire Spring for Bezel | 23 Coil Spring | 31 Set Screw for Back (S-128) |
| 08*Set Screw for Base Metal (S-217) | 16*Set Screw for Upper Metal (S-010) | 24*Shock-Proof Rubber | |

*mark are not for sell.

Dial Lens Gauge

GL

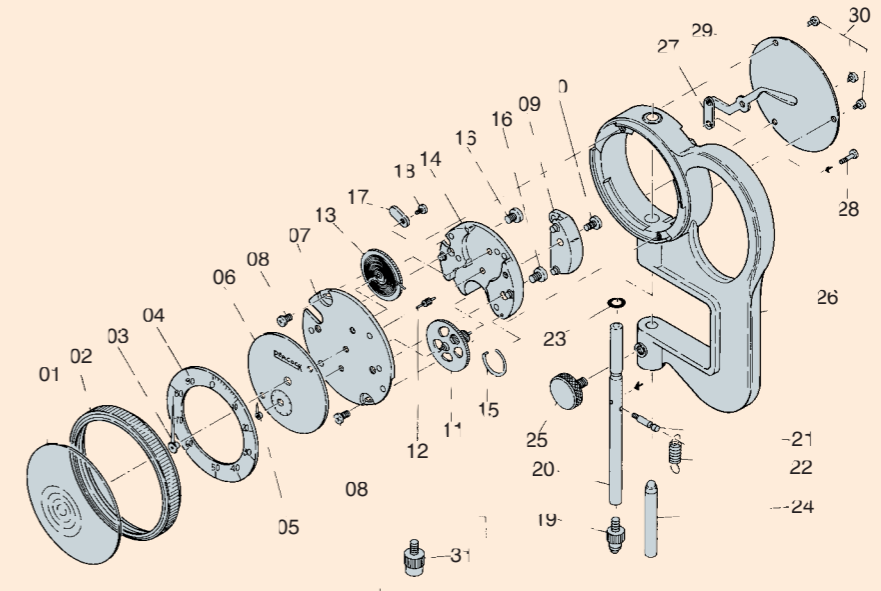

- | | | | |
|-------------------------------------|--------------------------------------|-------------------------------|-----------------------------------|
| 01 Crystal | 09*Guide Metal | 17*Claw | 25 Knob for Anvil |
| 02 Bezel | 10*Set Screw for Guide Metal (S-012) | 18*Set Screw for Claw (S-009) | 26*Frame |
| 03 Pointer | 11*120Z Main Gear (with 16Z Pinion) | 19 Contact Point (R-Type) | 27 Lever (with Lift Knock device) |
| 04 Outer Dial | 12*12Z Pinion | 20 Spindle | 28 Set Screw for Lift (S-064) |
| 05 Hand | 13*120Z Idle Gear (with Hair Spring) | 21*Guide Knock | 29 Back |
| 06 Inner Dial | 14*Upper Metal (with Spindle Jewel) | 22 Coil Spring | 30 Set Screw for Back (S-128) |
| 07*Base Metal (with Jewel) | 15*Wire Spring for Bezel | 23*Shock-Proof Rubber | 31 Contact Point (Flat Type) |
| 08*Set Screw for Base Metal (S-217) | 16*Set Screw for Upper Metal (S-010) | 24 Anvil | |

*mark are not for sell.

Parts Drawings

Cylinder Gauges

Cylinder Gauge CC-02

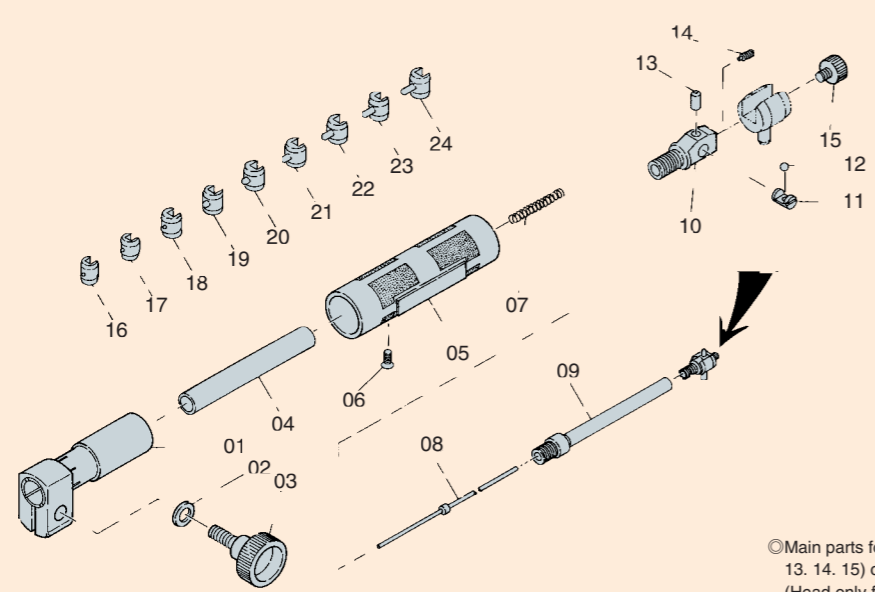

◎Main parts for Body (part no. 10. 11. 12. 13. 14. 15) can be sold as a set. (Head only for CC-02)

◎Parts no. 02 and 03 can be sold as a set.

- | | | | |
|--------------------------------|----------------------------------|--------------------------|------------------|
| 01 Indicator Holder | 07 Coil Spring | 13 Contact Point | 19 Feeler 7.5mm |
| 02 Washer | 08 Spindle (with Spindle Collar) | 14 Guide Screw | 20 Feeler 8.0mm |
| 03 Knob Screw | 09**Sleeve A | 15 Lock Screw for Feeler | 21 Feeler 8.5mm |
| 04**Sleeve B | 10**Head | 16 Feeler 6.0mm | 22 Feeler 9.0mm |
| 05**Grip | 11 Race | 17 Feeler 6.5mm | 23 Feeler 10.0mm |
| 06**Set Screw for Grip (S-027) | 12 Transmission Ball | 18 Feeler 7.0mm | |

**mark are not for sell.

Parts Drawings

Cylinder Gauges

Cylinder Gauge CC-1

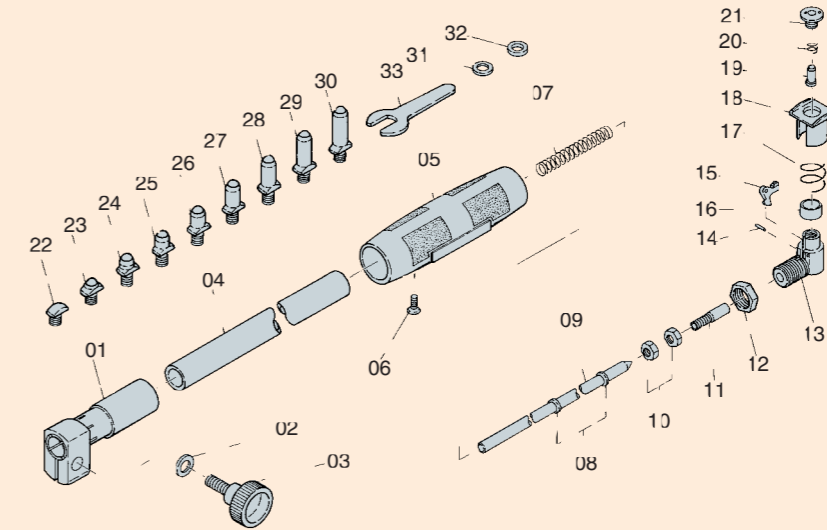

◎Main parts for Body (part no. 10. 11. 12. 13. 14. 15. 16. 17. 18. 19. 20. 21) can be sold as a set. (Head only for CC-1)

◎Parts no. 02 and 03 can be sold as a set.

◎Parts no. 14 and 15 can be sold as a set.

- | | | | | |
|-------------------------------------------|----------------------|------------------|-----------------|---------------------------------------------------------------------------------------------------------------------------|
| 01 Indicator Holder | 09 Spindle Rod | 18 Guide | 27 Feeler 28mm | ◎Main parts for Body (part no. 10. 11. 12. 13. 14. 15. 16. 17. 18. 19. 20. 21) can be sold as a set. (Head only for CC-1) |
| 02 Washer | 10 Stop Nut | 19 Contact Point | 28 Feeler 30mm | |
| 03 Knob Screw | 11 Spindle | 20 Buffer Spring | 29 Feeler 32mm | |
| 04**Sleeve | 12 Hex Nut | 21 Lock Nut | 30 Feeler 34mm | |
| 05**Grip | 13**Head | 22 Feeler 18mm | 31 Washer 0.5mm | |
| 06**Set Screw for Grip (S-021) | 14**Transmission Pin | 23 Feeler 20mm | 32 Washer 1mm | |
| 07 Coil Spring | 15**Transmission | 24 Feeler 22mm | 33 Spanner | |
| 08 Spindle Collar (with E type Stop Ring) | 16**Collar | 25 Feeler 24mm | | |
| | 17 Return Spring | 26 Feeler 26mm | | |
| | | | | |
| | | | | |
| | | | | |
| | | | | |

**mark are not for sell.

Cylinder Gauge CC-01

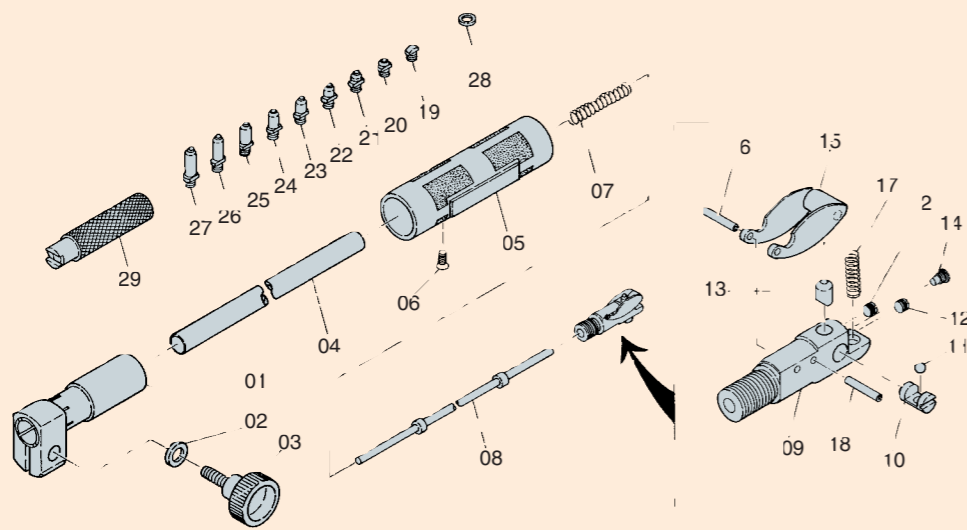

◎Main parts for Body (part no. 09. 10. 11. 12. 13. 14. 15. 16. 17. 18) can be sold as a set. (Head only for CC-01)

◎Parts no. 02 and 03 can be sold as a set.

- | | | |
|----------------------------------|--------------------------------------------|-----------------|
| 01 Indicator Holder | 11 Transmission Ball | 20 Feeler 11mm |
| 02 Washer | 12 Set Screw for Transmission Ball (S-049) | 21 Feeler 12mm |
| 03 Knob Screw | 13 Contact Point | 22 Feeler 13mm |
| 04**Sleeve | 14 Guide Screw | 23 Feeler 14mm |
| 05**Grip | 15 Guide (with Guide Bush) | 24 Feeler 15mm |
| 06**Set Screw for Grip (S-023) | 16 Rivet | 25 Feeler 16mm |
| 07 Coil Spring | 17 Return Spring | 26 Feeler 17mm |
| 08 Spindle (with Spindle Collar) | 18 Check Pin | 27 Feeler 18mm |
| 09**Head | 19 Feeler 10mm | 28 Washer 0.5mm |
| 10 Race | | 29 Spanner |

**mark are not for sell.

Cylinder Gauge CC-2

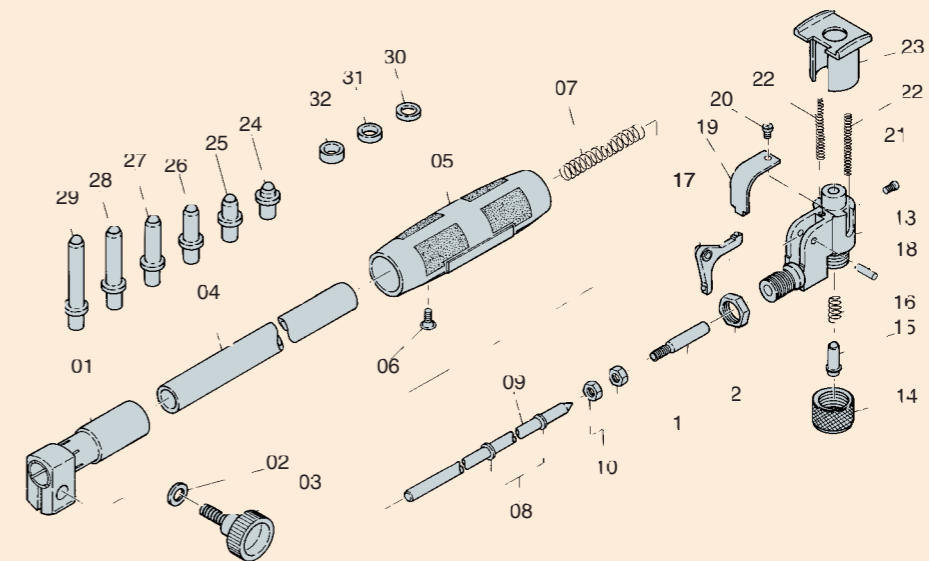

◎Main parts for Body (part no. 10. 11. 12. 13. 14. 15. 16. 17. 18. 19. 20. 21. 22. 23) can be sold as a set. (Head only for CC-2)

◎Parts no. 02 and 03 can be sold as a set.

◎Parts no. 17 and 18 can be sold as a set.

- | | | | | |
|-------------------------------------------|--------------------|--------------------------------------|----------------|-----------------------------------------------------------------------------------------------------------------------------------|
| 01 Indicator Holder | 09 Spindle Rod | 18 Transmission Pin | 27 Feeler 50mm | ◎Main parts for Body (part no. 10. 11. 12. 13. 14. 15. 16. 17. 18. 19. 20. 21. 22. 23) can be sold as a set. (Head only for CC-2) |
| 02 Washer | 10 Stop Nut | 19**Head Cover | 28 Feeler 55mm | |
| 03 Knob Screw | 11 Spindle | 20**Set Screw for Head Cover (S-008) | 29 Feeler 60mm | |
| 04**Sleeve | 12 Hex Nut | 21 Set Screw for Guide (S-042) | 30 Washer 1mm | |
| 05**Grip | 13**Head | 22 Return Spring | 31 Washer 2mm | |
| 06**Set Screw for Grip (S-021) | 14 Feeler Lock Nut | 23 Guide | 32 Washer 3mm | |
| 07 Coil Spring | 15 Contact Point | 24 Feeler 35mm | | |
| 08 Spindle Collar (with E type Stop Ring) | 16 Buffer Spring | 25 Feeler 40mm | | |
| | 17 Transmission | 26 Feeler 45mm | | |
| | | | | |
| | | | | |
| | | | | |
| | | | | |

**mark are not for sell.

Parts Drawings

Cylinder Gauges

Cylinder Gauge CC-3C

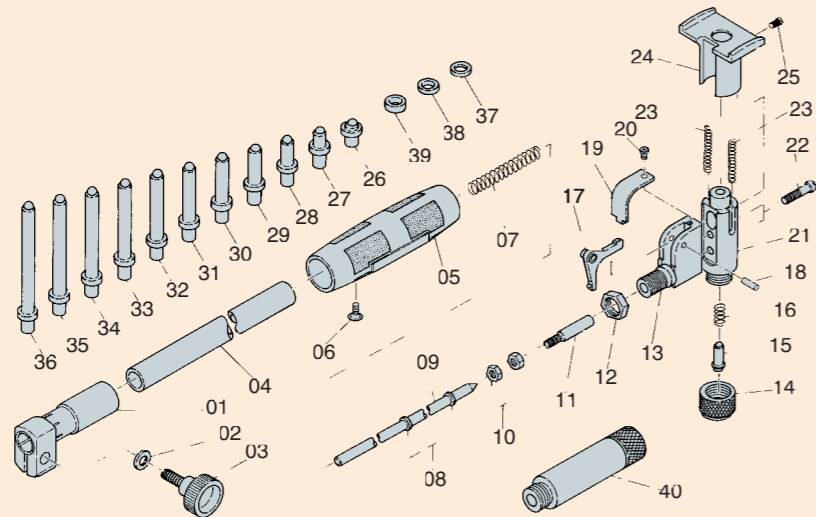

- | | | | | |
|-------------------------------------------|--------------------------------------|---------------------------------|-----------------|--------------------------------------------------------------------------------------------------------------------------------------------|
| 01 Indicator Holder | 11 Spindle | 22**Lock Screw for Head (S-025) | 31 Feeler 75mm | ◎Main parts for Body (part no. 10, 11, 12, 13, 14, 15, 16, 17, 18, 19, 20, 21, 22, 23, 24, 25) can be sold as a set. (Head only for CC-3C) |
| 02 Washer | 12 Hex Nut | 23 Return Spring | 32 Feeler 80mm | |
| 03 Knob Screw | 13**Head A | 24 Guide | 33 Feeler 85mm | ◎Parts no. 02 and 03 can be sold as a set. |
| 04**Sleeve | 14 Nut (Feeler Lock Nut) | 25 Set Screw for Guide (S-042) | 34 Feeler 90mm | |
| 05**Grip | 15 Contact Point | 26 Feeler 50mm | 35 Feeler 95mm | ◎Parts no. 17 and 18 can be sold as a set. |
| 06**Set Screw for Grip (S-021) | 16 Buffer Spring | 27 Feeler 55mm | 36 Feeler 100mm | |
| 07 Coil Spring | 17 Transmission | 28 Feeler 60mm | 37 Washer 1mm | |
| 08 Spindle Collar (with E type Stop Ring) | 18 Transmission Pin | 29 Feeler 65mm | 38 Washer 2mm | |
| 09 Spindle Rod | 19**Head Cover | 30 Feeler 70mm | 39 Washer 3mm | |
| 10 Stop Nut | 20**Set Screw for Head Cover (S-008) | | 40 Adapter | |
| | 21**Head B | | | |

**mark are not for sell.

Parts Drawings

Cylinder Gauges

Cylinder Gauge CC-5

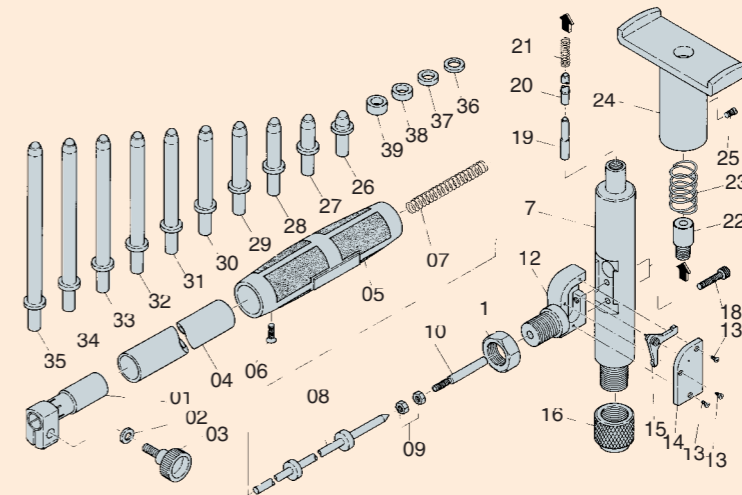

- | | | | | |
|--------------------------------------|-----------------------------------------|---------------------------------|--------------------------------|-----------------|
| 01 Indicator Holder | 09 Stop Nut | 16 Nut (Feeler Lock Nut) | 24 Guide | 32 Feeler 220mm |
| 02 Washer | 10 Spindle | 17**Head B | 25 Set Screw for Guide (S-043) | 33 Feeler 230mm |
| 03 Knob Screw | 11 Hex Nut | 18**Lock Screw for Head (S-208) | 26 Feeler 160mm | 34 Feeler 240mm |
| 04**Sleeve | 12**Head A | 19 Transmission Rod | 27 Feeler 170mm | 35 Feeler 250mm |
| 05**Grip | 13**Set Screw for Side Cover (S-017) | 20 Contact Point | 28 Feeler 180mm | 36 Washer 1mm |
| 06**Set Screw for Grip (S-031) | 14**Side Cover (with Transmission Pin) | 21 Buffer Spring | 29 Feeler 190mm | 37 Washer 2mm |
| 07 Coil Spring | 15 Transmission (with Transmission Pin) | 22**Lock Nut | 30 Feeler 200mm | 38 Washer 3mm |
| 08 Spindle Rod (with Spindle Collar) | | 23 Return Spring | 31 Feeler 210mm | 39 Washer 4mm |

◎Main parts for Body (part no. 09, 10, 11, 12, 13, 14, 15, 16, 17, 18, 19, 20, 21, 22, 23, 24, 25) can be sold as a set. (Head only for CC-5)

◎Parts no. 02 and 03 can be sold as a set.

**mark are not for sell.

Cylinder Gauge CC-4

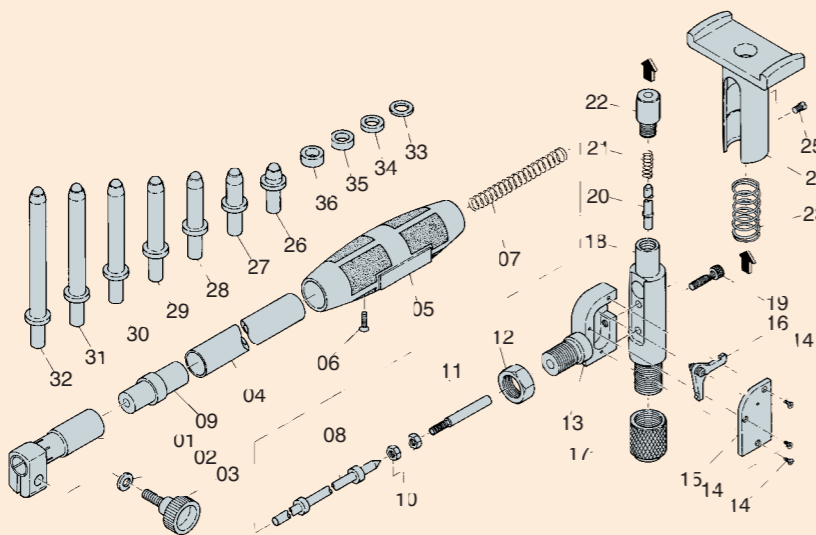

- | | | | | |
|--------------------------------------|-----------------------------------------|--------------------------------|-----------------|-------------------------------------------------------------------------------------------------------------------------------------------|
| 01 Indicator Holder | 11 Spindle | 20 Contact Point | 29 Feeler 130mm | ◎Main parts for Body (part no. 10, 11, 12, 13, 14, 15, 16, 17, 18, 19, 20, 21, 22, 23, 24, 25) can be sold as a set. (Head only for CC-4) |
| 02 Washer | 12 Hex Nut | 21 Buffer Spring | 30 Feeler 140mm | |
| 03 Knob Screw | 13**Head A | 22**Lock Nut | 31 Feeler 150mm | ◎Parts no. 02 and 03 can be sold as a set. |
| 04**Sleeve | 14**Set Screw for Side Cover (S-017) | 23 Return Spring | 32 Feeler 160mm | |
| 05**Grip | 15**Side Cover | 24 Guide | 33 Washer 1mm | |
| 06**Set Screw for Grip (S-028) | 16 Transmission (with Transmission Pin) | 25 Set Screw for Guide (S-043) | 34 Washer 2mm | |
| 07 Coil Spring | 17 Nut (Feeler Lock Nut) | 26 Feeler 100mm | 35 Washer 3mm | |
| 08 Spindle Rod (with Spindle Collar) | 18**Head B | 27 Feeler 110mm | 36 Washer 4mm | |
| 09**Joint | 19**Lock Screw for Head (S-207) | 28 Feeler 120mm | | |
| 10 Stop Nut | | | | |

**mark are not for sell.

Cylinder Gauge CC-6

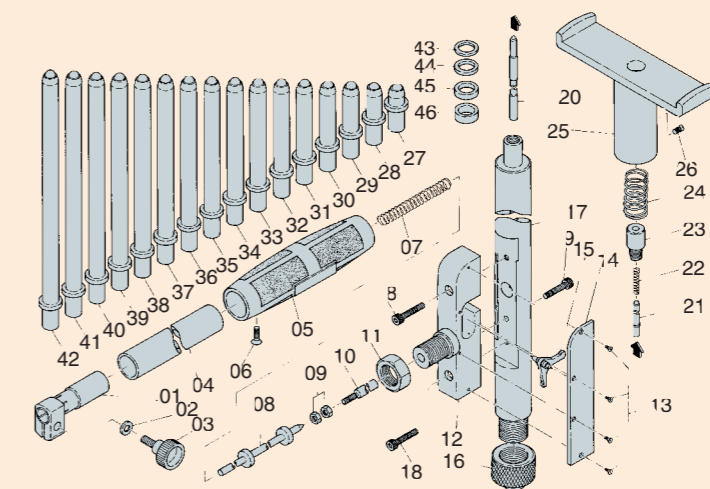

- | | | | | |
|--------------------------------------|-----------------------------------------|-----------------------------------|-----------------|-----------------|
| 01 Indicator Holder | 11 Hex Nut | 19**Lock Screw for Head B (S-208) | 28 Feeler 260mm | 39 Feeler 370mm |
| 02 Washer | 12**Head A | 20 Transmission Rod | 29 Feeler 270mm | 40 Feeler 380mm |
| 03 Knob Screw | 13**Set Screw for Side Cover (S-017) | 21 Contact Point | 30 Feeler 280mm | 41 Feeler 390mm |
| 04**Sleeve | 14**Side Cover (with Transmission Pin) | 22 Buffer Spring | 31 Feeler 290mm | 42 Feeler 400mm |
| 05**Grip | 15 Transmission (with Transmission Pin) | 23**Lock Nut | 32 Feeler 300mm | 43 Washer 1mm |
| 06**Set Screw for Grip (S-031) | 16 Nut (Feeler Lock Nut) | 24 Return Spring | 33 Feeler 310mm | 44 Washer 2mm |
| 07 Coil Spring | 17**Head B | 25 Guide | 34 Feeler 320mm | 45 Washer 3mm |
| 08 Spindle Rod (with Spindle Collar) | 18**Lock Screw for Head A (S-209) | 26 Set Screw for Guide (S-043) | 35 Feeler 330mm | 46 Washer 4mm |
| 09 Stop Nut | | 27 Feeler 250mm | 36 Feeler 340mm | |
| 10 Spindle | | | 37 Feeler 350mm | |
| | | | 38 Feeler 360mm | |

◎Main parts for Body (part no. 09, 10, 11, 12, 13, 14, 15, 16, 17, 18, 19, 20, 21, 22, 23, 24, 25, 26) can be sold as a set. (Head only for CC-6)

◎Parts no. 02 and 03 can be sold as a set.

**mark are not for sell.



Offset Contact Point No. X-13 New

- Unique Contact Point not existing before!
It is possible to make a measurement of an object that used to be impossible to measure.



■ Dimension

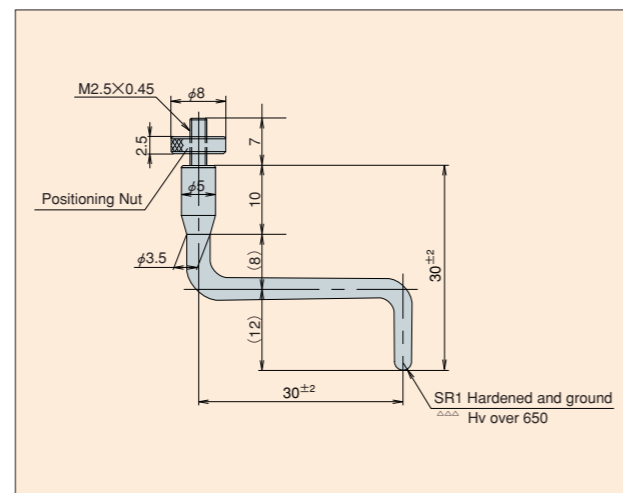

MEMO

≡ SINCE 1916 ≡



OZAKI MFG. CO., LTD.

1-63-11 TOKIWADAI, ITABASHI-KU, TOKYO 174-0071 JAPAN

TEL:81-3-3966-1109

FAX:81-3-3558-1868

BRANCHES: TOKYO, OSAKA, NAGOYA, CHIBA

FACTORIES: CHIBA, AKITA

URL:<http://www.peacockozaki.jp>

Specifications and appearance are subject to change without notice due to improvement
