

PRECISION BORE GAGE



2825-160A



2126-35

DATA OUTPUT

ceramic contact point

ceramic anvil

ceramic anvil

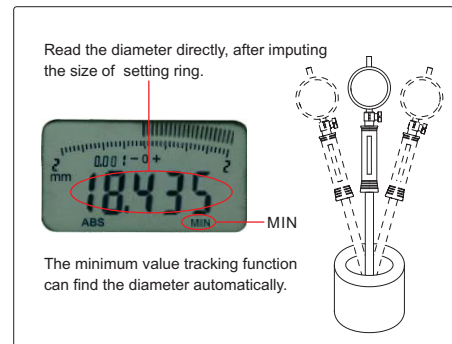
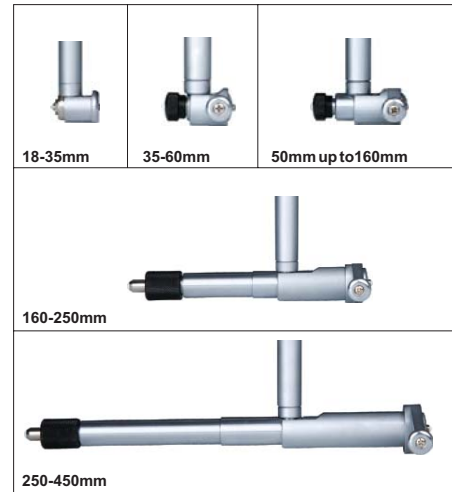

Optional accessory: setting ring (code 6312)

Code	Range	Indicator	Accuracy	Repeatability
2825-35A	18-35mm	dial indicator, range 1mm, graduation 0.001mm (code 2313-1FA)	±0.006mm	0.002mm
2825-60A	35-60mm		±0.007mm	0.002mm
2825-100A	50-100mm		±0.007mm	0.002mm
2825-160A	50-160mm		±0.007mm	0.002mm
2825-161A	100-160mm		±0.007mm	0.002mm
2825-250A	160-250mm		±0.007mm	0.002mm
2825-450A	250-450mm		±0.007mm	0.002mm

Code	Range	Indicator	Accuracy	Repeatability
2126-35	18-35mm	digital indicator, range 12.7mm/0.5", resolution 0.001mm/0.00005" (code 2108-101F)	±0.006mm	0.002mm
2126-60	35-60mm		±0.007mm	0.002mm
2126-100	50-100mm		±0.007mm	0.002mm
2126-160	50-160mm		±0.007mm	0.002mm
2126-161	100-160mm		±0.007mm	0.002mm
2126-250	160-250mm		±0.007mm	0.002mm
2126-450	250-450mm		±0.007mm	0.002mm

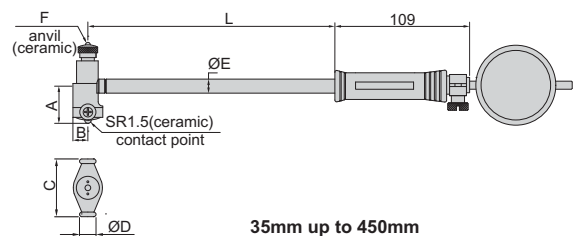
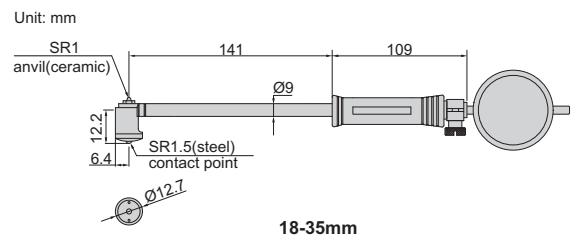

Range	A	B	C	ØD	ØE	F	L
35-60mm	12.2	6.4	27	13	12.8	SR2	141
50-100mm	26	9	27	13	12.8	SR2	141
50-160mm	26	9	35	13	12.8	SR2	141
100-160mm	26	9	35	13	12.8	SR2	141
160-250mm	56.5	13	74.5	15	12.8	SR2	241
250-450mm	86.5	15	101.5	15	14.5	SR2.5	241