

# Mechanical External Micrometer

**RANGE: 0-200 mm/0-8"**

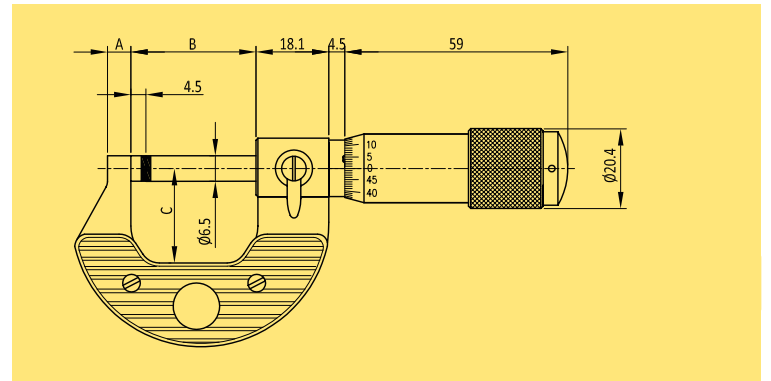

6MMA150

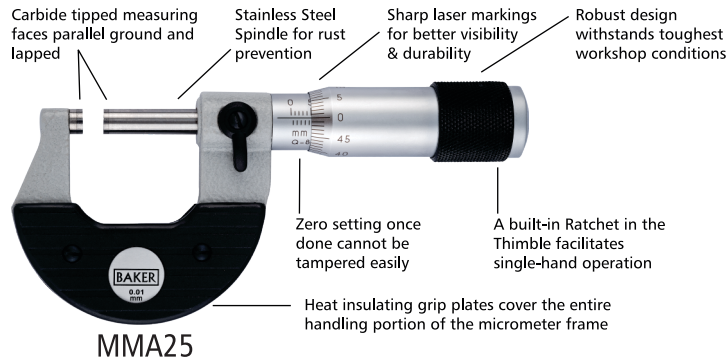

SET OF 6 MICROMETERS (0-150 mm/ 0-6")

4MMA100



SET OF 4 MICROMETERS (0-100 mm/ 0-4")

Measuring Range mm	Reading mm	Type	A mm	B mm	C mm	Measuring Range inch	Reading inch	Type
0-25	0.01	MMA25	7.1	32.5	25.5	0-1"	0.001"	INA1
	0.001	MMA25-1					0.0001"	INA1-1
25-50	0.01	MMA50	7.1	57.5	30.5	1-2"	0.001"	INA2
	0.001	MMA50-1					0.0001"	INA2-1
50-75	0.01	MMA75	8	83	45	2-3"	0.001"	INA3
	0.001	MMA75-1					0.0001"	INA3-1
75-100	0.01	MMA100	8	108	58	3-4"	0.001"	INA4
	0.001	MMA100-1					0.0001"	INA4-1
100-125	0.01	MMA125	8	133	67.5	4-5"	0.001"	INA5
	0.001	MMA125-1					0.0001"	INA5-1
125-150	0.01	MMA150	8	158	82	5-6"	0.001"	INA6
	0.001	MMA150-1					0.0001"	INA6-1
150-175	0.01	MMA175	8	183	93	6-7"	0.001"	INA7
175-200	0.01	MMA200	8	208	108	7-8"	0.001"	INA8
<b>Set of Micrometers</b>								
0 -100 (Set of 4)	0.01	4MMA100	-			0-4" (Set of 4)	0.001"	4INA4
	0.001	4MMA100-1					0.0001"	4INA4-1
0 -150 (Set of 6)	0.01	6MMA150	-			0-6" (Set of 6)	0.001"	6INA6
	0.001	6MMA150-1					0.0001"	6INA6-1

## FEATURES

- Specifications : IS, DIN, ANSI & JIS
- Spindle made from stainless steel for rust prevention
- Measuring faces: carbide tipped, precision ground & micro lapped
- An in-built ratchet in the thimble
- Zero setting once done cannot be easily tampered with
- Sharp laser marking for better visibility & durability
- Heat insulating grip plates cover the entire handling portion of the micrometer frame
- Robust design withstands toughest workshop conditions