



<b>Index</b>	
<b>Description</b>	<b>Page No</b>
HSS Square Tools Bits   (Metric & Imperial Sizes)	2
HSS Parting Blades   (Imperial Sizes)	3
HSS Rectangular Tools Bits   (Metric & Imperial Sizes)	4
HSS Round Tool Bits   (Metric & Imperial Sizes)	5
HSS Punches   (P101 Series)	6
HSS Parallel Shank End Mills   (As per IS 6353 - 1991)	7
HSS Parallel Shank End Mills   (As per BS-122)	7
HSS Centre Drills Type 'A'   (As per BS 328)	8
HSS Centre Drills Type 'A'   (As per DIN 333)	8
HSS Drills   (As per DIN 338)	9
HSS Coarse Pitch Machine Taps   (As per ISO 529)	10
HSS Coarse Pitch Machine Taps TIN Coated   (As per ISO 529)	10

<b>Grade Selection</b>			
<b>HSS Grades (AISI Standard - % age of Cobalt)</b>	<b>Rohit Grade</b>	<b>Hardness</b>	<b>AISI Std.</b>
AISI M2 - 0% Cobalt	1X	62-65	AISI M2
AISI M35 - 5% Cobalt	2X	63-66	AISI M35
AISI M42 - 8% Cobalt	Sp	65-68	AISI M42
AISI T42 - 10% Cobalt	3X	65-67	AISI T42
AISI T42 - 10% Cobalt - Cryogenic Treated	EC-500	65-67	AISI T42

<b>Terms &amp; Conditions</b>
1. GST will be charged Extra as applicable
2. Delivery F.O.R (Free on Road) Destination
3. For Unlisted Intermediate Sizes, Price of Next Higher Size in Inch or MM will Apply with Minimum Order Value = INR 5,000/- or MOQ whichever is higher.
4. We also manufacture Special Sizes / Intermediate Sizes in HSS Tool Bits
5. If coating is (TiAlN, TiN, TiCN) required then price will be charged extra if Coated Prices are not given in Price List. Minimum Order Value of INR 5,000/- each size or MOQ whichever is higher
6. No Loose packing will be entertained so follow the Pack size while ordering for tools
7. Intermediate sizes in HSS Punches (P101) i.e. 0.01mm increment will be associated with Minimum Order Value of INR 5,000/- Per Size or MOQ whichever is higher and Special Price will be applicable for the same
8. Company Reserves the right to change the Price List without prior information.

<b>Safe use of cutting tools</b>
- Use safety cover, safety glasses and safety shoes during operation.
- Do not touch cutting edges with bare hands.
- Do not touch cutting chips with bare hands. Chips will be hot after cutting.
- Stop cutting when the tool becomes dull.
- Stop cutting operation immediately if you hear any abnormal cutting sounds.
- Do not modify tools.
- Please use appropriate tools for the operation. Check dimensions to ensure proper selection.



HSS Square Tool Bits		PL-51 (Price Per Piece in INR)						
Ref No.	SIZE	1X (M2, 0%Co)	2X (M35, 5%Co)	Sp (M42, 8%Co)	3X (T42, 10%Co)	EC-500 (T42-Cryo)	3X - TiN Coated	EC-500 - TiN Coated
s1	3x3x75	₹ 90	₹ 117	₹ 180	₹ 216	₹ 261		
s2	3x3x100	₹ 117	₹ 156	₹ 240	₹ 291	₹ 345		
s3	1/8"x1/8"x3"	₹ 90	₹ 117	₹ 180	₹ 216	₹ 261		
s4	1/8"x1/8"x4"	₹ 117	₹ 156	₹ 240	₹ 291	₹ 345		
s5	3/16"x3/16"x3"	₹ 90	₹ 117	₹ 180	₹ 216	₹ 261		
s6	3/16"x3/16"x4"	₹ 117	₹ 156	₹ 240	₹ 291	₹ 345		
s7	3/16"x3/16"x6"	₹ 174	₹ 234	₹ 357	₹ 447	₹ 531		
s8	5x5x75	₹ 90	₹ 117	₹ 180	₹ 216	₹ 261		
s9	5x5x100	₹ 117	₹ 156	₹ 240	₹ 291	₹ 345		
s10	5x5x150	₹ 174	₹ 234	₹ 357	₹ 447	₹ 531		
s11	6x6x75	₹ 96	₹ 135	₹ 177	₹ 237	₹ 267		
s12	6x6x100	₹ 126	₹ 171	₹ 237	₹ 312	₹ 351		
s13	6x6x150	₹ 183	₹ 261	₹ 339	₹ 492	₹ 555		
s14	6x6x200	₹ 243	₹ 339	₹ 489	₹ 672	₹ 750		
s15	1/4"x1/4"x3"	₹ 96	₹ 135	₹ 177	₹ 237	₹ 267		
s16	1/4"x1/4"x4"	₹ 126	₹ 171	₹ 237	₹ 312	₹ 351		
s17	1/4"x1/4"x6"	₹ 183	₹ 261	₹ 339	₹ 492	₹ 555		
s18	1/4"x1/4"x8"	₹ 243	₹ 339	₹ 489	₹ 672	₹ 750		
s19	5/16"x5/16"x3"	₹ 129	₹ 180	₹ 285	₹ 360	₹ 408		
s20	5/16"x5/16"x4"	₹ 171	₹ 240	₹ 369	₹ 486	₹ 555		
s21	5/16"x5/16"x6"	₹ 255	₹ 357	₹ 588	₹ 735	₹ 828		
s22	5/16"x5/16"x8"	₹ 336	₹ 474	₹ 831	₹ 957	₹ 1,077		
s23	8x8x75	₹ 129	₹ 180	₹ 285	₹ 360	₹ 408		
s24	8x8x100	₹ 171	₹ 240	₹ 369	₹ 486	₹ 555		
s25	8x8x150	₹ 255	₹ 357	₹ 588	₹ 735	₹ 828		
s26	8x8x200	₹ 336	₹ 474	₹ 831	₹ 957	₹ 1,077		
s27	3/8"x3/8"x3"	₹ 174	₹ 240	₹ 345	₹ 408	₹ 456		
s28	3/8"x3/8"x4"	₹ 222	₹ 321	₹ 459	₹ 546	₹ 597		
s29	3/8"x3/8"x6"	₹ 336	₹ 477	₹ 684	₹ 813	₹ 912		
s30	3/8"x3/8"x8"	₹ 435	₹ 636	₹ 957	₹ 1,116	₹ 1,245	₹ 1,347	₹ 1,476
s31	3/8"x3/8"x10"	₹ 579	₹ 855	₹ 1,275	₹ 1,503	₹ 1,689	₹ 1,734	
s32	10x10x75	₹ 183	₹ 249	₹ 369	₹ 447	₹ 495		
s33	10x10x100	₹ 243	₹ 339	₹ 489	₹ 597	₹ 684		
s34	10x10x150	₹ 360	₹ 498	₹ 732	₹ 927	₹ 1,041		
s35	10x10x200	₹ 480	₹ 672	₹ 1,023	₹ 1,275	₹ 1,407		
s36	10x10x250	₹ 618	₹ 894	₹ 1,365	₹ 1,698	₹ 1,890		



HSS Square Tool Bits		PL-51 (Price Per Piece in INR)						
Ref No.	SIZE	1X (M2, 0%Co)	2X (M35, 5%Co)	Sp (M42, 8%Co)	3X (T42, 10%Co)	EC-500 (T42-Cryo)	3X - TiN Coated	EC-500 - TiN Coated
s37	12x12x75	₹ 255	₹ 357	₹ 555	₹ 672	₹ 735		
s38	12x12x100	₹ 336	₹ 477	₹ 756	₹ 852	₹ 936		
s39	12x12x150	₹ 501	₹ 714	₹ 1,116	₹ 1,380	₹ 1,542		
s40	12x12x200	₹ 669	₹ 951	₹ 1,488	₹ 1,860	₹ 2,016		
s41	12x12x250	₹ 822	₹ 1,260	₹ 2,016	₹ 2,403	₹ 2,655		
s42	1/2"x1/2"x3"	₹ 255	₹ 357	₹ 555	₹ 672	₹ 735		
s43	1/2"x1/2"x4"	₹ 336	₹ 477	₹ 756	₹ 867	₹ 936		
s44	1/2"x1/2"x6"	₹ 501	₹ 714	₹ 1,116	₹ 1,380	₹ 1,542		
s45	1/2"x1/2"x8"	₹ 669	₹ 951	₹ 1,488	₹ 1,860	₹ 2,016	₹ 2,112	₹ 2,343
s46	1/2"x1/2"x10"	₹ 822	₹ 1,203	₹ 2,016	₹ 2,403	₹ 2,655		
s47	5/8"x5/8"x4"	₹ 507	₹ 738	₹ 1,170	₹ 1,488	₹ 1,593		
s48	5/8"x5/8"x6"	₹ 756	₹ 1,107	₹ 1,749	₹ 2,178	₹ 2,385		
s49	5/8"x5/8"x8"	₹ 1,002	₹ 1,473	₹ 2,337	₹ 2,916	₹ 3,180		
s50	16x16x100	₹ 507	₹ 738	₹ 1,170	₹ 1,488	₹ 1,593		
s51	16x16x150	₹ 756	₹ 1,107	₹ 1,749	₹ 2,178	₹ 2,385		
s52	16x16x200	₹ 1,002	₹ 1,473	₹ 2,337	₹ 2,916	₹ 3,180		
s53	3/4"x3/4"x4"	₹ 735	₹ 1,107	₹ 1,698	₹ 2,016	₹ 2,283		
s54	3/4"x3/4"x6"	₹ 1,101	₹ 1,638	₹ 2,439	₹ 3,075	₹ 3,393		
s55	3/4"x3/4"x8"	₹ 1,464	₹ 2,205	₹ 3,234	₹ 4,026	₹ 4,398		
s56	20x20x100	₹ 756	₹ 1,161	₹ 1,749	₹ 2,121	₹ 2,283		
s57	20x20x150	₹ 1,155	₹ 1,737	₹ 2,601	₹ 3,075	₹ 3,393		
s58	20x20x200	₹ 1,503	₹ 2,313	₹ 3,339	₹ 4,134	₹ 4,449		
s59	25x25x150	₹ 1,839	₹ 2,898	₹ 4,242	₹ 4,983	₹ 5,511		
s60	25x25x200	₹ 2,418	₹ 3,831	₹ 5,616	₹ 6,633	₹ 7,272		
s61	1"x1"x5"		₹ 2,418					
s62	1"x1"x6"	₹ 1,839	₹ 2,898	₹ 4,242	₹ 4,983	₹ 5,511		
s63	1"x1"x8"	₹ 2,418	₹ 3,831	₹ 5,616	₹ 6,633	₹ 7,272		

HSS Parting Blades		PL-51 (Price Per Piece in INR)		
Ref. No.	SIZE	1X (M2) - 0% Co	2X (M35) - 5% Co	3X (T42) - 10% Co
pa1	3/32"x1/2"x4"	₹ 186	₹ 369	₹ 615
pa2	3/32"x5/8"x5"	₹ 246	₹ 489	₹ 813
pa3	1/8"x3/4"x6"	₹ 366	₹ 558	₹ 1,203
pa4	1/8"x7/8"x6"	₹ 441	₹ 750	₹ 1,542
pa5	3/16"x1"x6"	₹ 693	₹ 1,026	₹ 1,935



HSS Rectangular Tool Bits		PL-51 (Price Per Piece in INR)		
Ref No.	SIZE	1X (M2, 0%Co)	2X (M35, 5%Co)	3X (T42, 10%Co)
r1	2x12x200	₹ 261		
r2	2x3/4"x8"	₹ 381		
r3	2.5x12x200	₹ 282		
r4	2.5x3/4"x8"	₹ 411		
r5	3x12x150	₹ 234		₹ 738
r6	3x12x200	₹ 318		₹ 975
r7	3x25x150	₹ 441	₹ 654	₹ 1,353
r8	3x25x200	₹ 594	₹ 873	₹ 1,785
r9	1/8"x3/8"x8"	₹ 282		₹ 738
r10	1/8"x1/2"x6"	₹ 234		₹ 738
r11	1/8"x1/2"x8"	₹ 318		₹ 975
r12	1/8"x3/4"x6"	₹ 318	₹ 483	₹ 924
r13	1/8"x3/4"x8"	₹ 423	₹ 675	₹ 1,275
r14	1/8"x1"x6"	₹ 441	₹ 654	₹ 1,353
r15	1/8"x1"x8"	₹ 594	₹ 873	₹ 1,785
r16	5/32"x3/4"x6"	₹ 381		
r17	5/32"x3/4"x8"	₹ 501		
r18	3/16"x1/2"x6"	₹ 354		₹ 882
r19	3/16"x1/2"x8"	₹ 486		₹ 1,203
r20	3/16"x3/4"x6"	₹ 423		
r21	3/16"x3/4"x8"	₹ 561		
r22	3/16"x1"x6"	₹ 612		
r23	3/16"x1"x8"	₹ 810		
r24	5x25x150	₹ 612		
r25	5x25x200	₹ 810		
r26	6x12x100			₹ 609
r27	6x12x150			₹ 933
r28	6x12x200			₹ 1,245
r29	6x16x150	₹ 435	₹ 729	₹ 1,179
r30	6x16x200	₹ 582	₹ 975	₹ 1,626
r31	6x25x150	₹ 612	₹ 999	₹ 1,686
r32	6x25x200	₹ 828	₹ 1,350	₹ 2,205
r33	1/4"x1/2"x4"			₹ 609
r34	1/4"x1/2"x6"			₹ 933
r35	1/4"x1/2"x8"			₹ 1,245
r36	1/4"x5/8"x6"	₹ 435	₹ 729	₹ 1,179
r37	1/4"x5/8"x8"	₹ 582	₹ 975	₹ 1,626
r38	1/4"x3/4"x6"	₹ 468	₹ 825	₹ 1,686
r39	1/4"x3/4"x8"	₹ 639	₹ 1,107	₹ 2,205
r40	1/4"x1"x6"	₹ 612	₹ 999	₹ 1,686
r41	1/4"x1"x8"	₹ 828	₹ 1,350	₹ 2,205

HSS Rectangular Tool Bits		PL-51 (Price Per Piece in INR)		
Ref No.	SIZE	1X (M2, 0%Co)	2X (M35, 5%Co)	3X (T42, 10%Co)
r42	5/16"x3/4"x6"	₹ 642		
r43	5/16"x3/4"x8"	₹ 858		
r44	8x20x63	₹ 300		
r45	3/8"x1/2"x4"	₹ 360	₹ 474	₹ 864
r46	3/8"x1/2"x6"	₹ 534	₹ 711	₹ 1,380
r47	3/8"x1/2"x8"	₹ 723	₹ 951	₹ 1,860
r48	3/8"x5/8"x6"		₹ 900	₹ 1,614
r49	3/8"x5/8"x8"		₹ 1,236	₹ 2,130
r50	3/8"x3/4"x6"	₹ 699	₹ 1,077	₹ 1,749
r51	3/8"x3/4"x8"	₹ 936	₹ 1,422	₹ 2,283
r52	3/8"x1"x6"	₹ 915	₹ 1,500	₹ 2,646
r53	3/8"x1"x8"	₹ 1,224	₹ 2,013	₹ 3,510
r54	3/8"x1+1/4"x6"	₹ 1,611		₹ 4,188
r55	3/8"x1+1/4"x8"	₹ 2,163		₹ 5,511
r56	3/8"x1+1/2"x6"	₹ 1,806		₹ 4,875
r57	3/8"x1+1/2"x8"	₹ 2,373		₹ 6,465
r58	12x16x150	₹ 750	₹ 1,104	₹ 2,301
r59	12x16x200	₹ 1,002	₹ 1,473	₹ 2,991
r60	12x25x150	₹ 1,188	₹ 1,959	₹ 2,934
r61	12x25x200	₹ 1,638	₹ 2,535	₹ 3,855
r62	1/2"x5/8"x6"	₹ 750	₹ 1,104	₹ 2,121
r63	1/2"x5/8"x8"	₹ 1,002	₹ 1,473	₹ 2,757
r64	1/2"x3/4"x6"	₹ 930	₹ 1,350	₹ 2,229
r65	1/2"x3/4"x8"	₹ 1,221	₹ 1,839	₹ 3,021
r66	1/2"x1"x6"	₹ 1,188	₹ 1,959	₹ 3,009
r67	1/2"x1"x8"	₹ 1,638	₹ 2,535	₹ 3,954
r68	1/2"x1+1/4"x6"	₹ 1,965		₹ 4,611
r69	1/2"x1+1/4"x8"	₹ 2,628		₹ 6,039
r70	1/2"x1+1/2"x6"	₹ 2,271		₹ 5,403
r71	1/2"x1+1/2"x8"	₹ 3,048		₹ 7,098
r72	5/8"x3/4"x6"	₹ 1,131	₹ 1,638	₹ 3,282
r73	5/8"x3/4"x8"	₹ 1,509	₹ 2,205	₹ 4,314
r74	5/8"x1"x6"	₹ 1,845	₹ 2,640	₹ 4,680
r75	5/8"x1"x8"	₹ 2,439	₹ 3,480	₹ 6,234
r76	16x25x150	₹ 1,845	₹ 2,640	₹ 4,680
r77	16x25x200	₹ 2,439	₹ 3,480	₹ 6,234
r78	3/4"x1"x6"	₹ 1,872	₹ 2,760	₹ 4,977
r79	3/4"x1"x8"	₹ 2,496	₹ 3,681	₹ 6,714
r80	20x25x150	₹ 1,872	₹ 2,760	₹ 4,977
r81	20x25x200	₹ 2,496	₹ 3,681	₹ 6,714



HSS Round Bits	PL-51 (Price Per Piece in INR)			
	1X (M2, 0%Co)	2X (M35, 5%Co)	Sp (M42, 8%Co)	3X (T42, 10%Co)
3x75	₹ 42	₹ 90	₹ 117	₹ 180
3x100	₹ 57	₹ 117	₹ 159	₹ 261
1/8"x3"	₹ 45	₹ 90	₹ 117	₹ 180
1/8"x4"	₹ 63	₹ 117	₹ 159	₹ 261
5/32"x3"	₹ 45			
5/32"x4"	₹ 63			
4x75	₹ 45			
4x100	₹ 63			
3/16"x3"	₹ 57	₹ 87	₹ 117	₹ 180
3/16"x4"	₹ 78	₹ 117	₹ 156	₹ 258
3/16"x6"	₹ 141	₹ 198	₹ 240	₹ 375
5x75	₹ 57	₹ 87	₹ 117	₹ 180
5x100	₹ 78	₹ 117	₹ 156	₹ 258
5x150	₹ 141	₹ 198	₹ 240	₹ 375
5.5x75	₹ 72			
5.5x100	₹ 93			
5.5x150	₹ 153			
7/32"x3"	₹ 72			
7/32"x4"	₹ 93			
7/32"x6"	₹ 153			
6x75	₹ 87	₹ 120	₹ 156	₹ 210
6x100	₹ 111	₹ 162	₹ 210	₹ 279
6x150	₹ 168	₹ 237	₹ 306	₹ 420
6x200	₹ 231	₹ 330	₹ 495	₹ 603
1/4"x3"	₹ 87	₹ 120	₹ 156	₹ 210
1/4"x4"	₹ 111	₹ 162	₹ 210	₹ 279
1/4"x6"	₹ 168	₹ 237	₹ 306	₹ 420
1/4"x8"	₹ 231	₹ 330	₹ 495	₹ 603
6.5x75	₹ 96			
6.5x100	₹ 123			
6.5x150	₹ 180			
6.5x200	₹ 273			
7x75	₹ 102			
7x100	₹ 129			
7x150	₹ 204			
7x200	₹ 273			
5/16"x3"	₹ 108	₹ 162	₹ 228	₹ 285
5/16"x4"	₹ 138	₹ 219	₹ 306	₹ 372
5/16"x6"	₹ 213	₹ 324	₹ 456	₹ 588
5/16"x8"	₹ 273	₹ 429	₹ 654	₹ 765
8x75	₹ 108	₹ 162	₹ 228	₹ 285
8x100	₹ 138	₹ 219	₹ 306	₹ 372
8x150	₹ 213	₹ 324	₹ 456	₹ 588
8x200	₹ 273	₹ 429	₹ 654	₹ 765
9x75	₹ 129	₹ 195	₹ 267	₹ 336
9x100	₹ 180	₹ 258	₹ 357	₹ 447
9x150	₹ 255	₹ 399	₹ 522	₹ 699
9x200	₹ 357	₹ 528	₹ 747	₹ 918
9x250	₹ 453	₹ 726	₹ 1,089	₹ 1,215
3/8"x3"	₹ 129	₹ 195	₹ 267	₹ 357
3/8"x4"	₹ 180	₹ 258	₹ 357	₹ 477
3/8"x6"	₹ 255	₹ 399	₹ 522	₹ 729

HSS Round Bits	PL-51 (Price Per Piece in INR)			
	1X (M2, 0%Co)	2X (M35, 5%Co)	Sp (M42, 8%Co)	3X (T42, 10%Co)
3/8"x8"	₹ 357	₹ 528	₹ 747	₹ 975
3/8"x10"	₹ 453	₹ 726	₹ 1,089	₹ 1,302
10x75	₹ 150	₹ 210	₹ 279	₹ 357
10x100	₹ 204	₹ 267	₹ 369	₹ 477
10x150	₹ 294	₹ 408	₹ 579	₹ 729
10x200	₹ 399	₹ 546	₹ 795	₹ 975
10x250	₹ 534	₹ 771	₹ 1,125	₹ 1,302
11x75	₹ 186			
11x100	₹ 240			
11x150	₹ 357			
12x75	₹ 222	₹ 324	₹ 411	₹ 591
12x100	₹ 300	₹ 429	₹ 546	₹ 792
12x150	₹ 441	₹ 642	₹ 819	₹ 1,155
12x200	₹ 591	₹ 852	₹ 1,125	₹ 1,563
12x250	₹ 777	₹ 1,065	₹ 1,656	₹ 1,947
1/2"x3"	₹ 222	₹ 324	₹ 411	₹ 591
1/2"x4"	₹ 300	₹ 429	₹ 546	₹ 792
1/2"x6"	₹ 441	₹ 642	₹ 819	₹ 1,155
1/2"x8"	₹ 591	₹ 852	₹ 1,125	₹ 1,563
1/2"x10"	₹ 777	₹ 1,065	₹ 1,656	₹ 1,947
13x75	₹ 255			
13x100	₹ 330			
13x150	₹ 495			
14x75	₹ 294			
14x100	₹ 399			
14x150	₹ 585			
14x200	₹ 795			
5/8"x4"	₹ 459	₹ 630	₹ 936	₹ 1,317
5/8"x6"	₹ 690	₹ 936	₹ 1,479	₹ 1,932
5/8"x8"	₹ 918	₹ 1,275	₹ 1,947	₹ 2,559
16x100	₹ 459	₹ 630	₹ 936	₹ 1,317
16x150	₹ 690	₹ 936	₹ 1,479	₹ 1,932
16x200	₹ 918	₹ 1,275	₹ 1,947	₹ 2,559
19x100	₹ 669	₹ 981	₹ 1,479	₹ 1,713
19x150	₹ 1,002	₹ 1,470	₹ 2,124	₹ 2,520
19x200	₹ 1,335	₹ 1,959	₹ 2,832	₹ 3,333
3/4"x4"	₹ 669	₹ 981	₹ 1,479	₹ 1,713
3/4"x6"	₹ 1,002	₹ 1,470	₹ 2,124	₹ 2,520
3/4"x8"	₹ 1,335	₹ 1,959	₹ 2,832	₹ 3,333
20x100	₹ 723	₹ 1,008	₹ 1,479	₹ 1,902
20x150	₹ 1,083	₹ 1,509	₹ 2,184	₹ 2,787
20x200	₹ 1,437	₹ 2,013	₹ 2,892	₹ 3,705
7/8"x4"	₹ 942			
7/8"x6"	₹ 1,410			
7/8"x8"	₹ 1,872			
25x100	₹ 1,125	₹ 1,728	₹ 2,244	₹ 2,940
25x150	₹ 1,686	₹ 2,592	₹ 3,423	₹ 4,341
25x200	₹ 2,247	₹ 3,450	₹ 4,485	₹ 5,721
1"x4"	₹ 1,125	₹ 1,728	₹ 2,244	₹ 2,940
1"x6"	₹ 1,686	₹ 2,592	₹ 3,423	₹ 4,341
1"x8"	₹ 2,247	₹ 3,450	₹ 4,485	₹ 5,721

HSS Punches (P-101 series)	PL-51 - 1X (M2, 0% Co) (Price Per Piece in INR)			
	L=50MM	L=75MM	L=100MM	L=150MM
Body Dia (mm)				
1	₹ 51	₹ 63	₹ 93	
1.5	₹ 45	₹ 57	₹ 90	
2	₹ 45	₹ 57	₹ 90	
2.5	₹ 54	₹ 63	₹ 90	
3	₹ 54	₹ 72	₹ 96	
3.5	₹ 57	₹ 81	₹ 102	
4	₹ 60	₹ 84	₹ 102	₹ 183
4.5	₹ 75	₹ 90	₹ 120	₹ 225
5	₹ 93	₹ 105	₹ 141	₹ 225
5.5	₹ 117	₹ 126	₹ 165	₹ 267
6	₹ 117	₹ 132	₹ 165	₹ 267
6.5	₹ 126	₹ 141	₹ 186	₹ 279
7	₹ 138	₹ 141	₹ 186	₹ 279
7.5	₹ 150	₹ 171	₹ 231	₹ 339
8	₹ 150	₹ 171	₹ 231	₹ 339
8.5	₹ 162	₹ 195	₹ 261	₹ 387
9	₹ 168	₹ 195	₹ 261	₹ 387
9.5	₹ 195	₹ 243	₹ 309	₹ 462
10	₹ 195	₹ 243	₹ 309	₹ 462
10.5	₹ 216	₹ 279	₹ 372	₹ 555
11	₹ 216	₹ 279	₹ 372	₹ 555
11.5	₹ 258	₹ 309	₹ 411	₹ 618
12	₹ 279	₹ 309	₹ 411	₹ 618
12.5	₹ 294	₹ 360	₹ 510	₹ 762
13	₹ 369	₹ 405	₹ 510	₹ 762
13.5	₹ 447	₹ 477	₹ 573	₹ 855
14	₹ 447	₹ 477	₹ 573	₹ 855
14.5	₹ 447	₹ 477	₹ 582	₹ 855
15	₹ 447	₹ 477	₹ 582	₹ 855
15.5		₹ 687	₹ 876	₹ 1,152
16		₹ 687	₹ 876	₹ 1,152
16.5		₹ 762	₹ 921	₹ 1,350
17		₹ 762	₹ 921	₹ 1,350
17.5		₹ 762	₹ 921	₹ 1,350
18		₹ 762	₹ 921	₹ 1,350
19		₹ 921	₹ 963	₹ 1,890
20		₹ 921	₹ 1,299	₹ 1,890

\*Head Dia (H) = Body Dia (P) + 1mm  
 \*OAL (L) is inclusive of the Head Length  
 \*Head Length (T) = 5mm for Lengths >= 75mm  
 \*Head Length(T) = 3mm for Lengths <=50mm

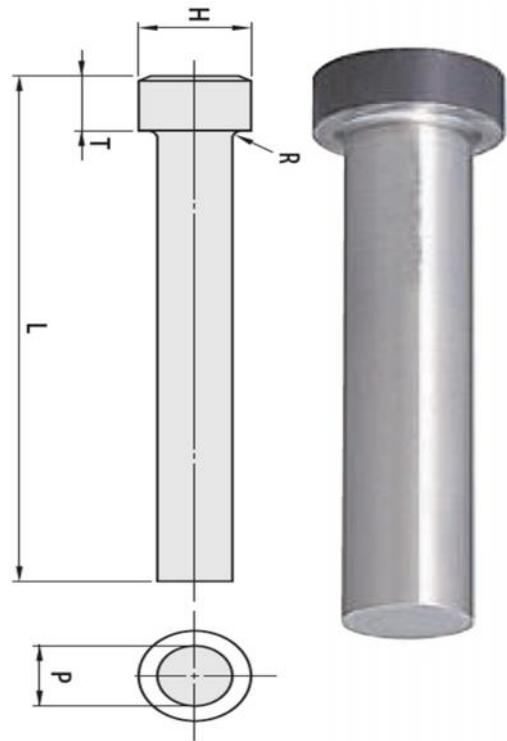



<b>HSS End Mills as per IS 6353 - 1991</b>				<b>PL-51 (Price Per Piece in INR)</b>	
Flute Dia (mm)	Flute Length (mm)	Overall Length (mm)	Shank Dia (mm)	1X (M2, 0%Co)	2X (M35, 5%Co)
3	10	42	3	₹ 171	₹ 213
4	11	43	4	₹ 171	₹ 213
5	13	47	5	₹ 171	₹ 213
6	16	52	6	₹ 180	₹ 219
7	16	52	6	₹ 252	₹ 288
8	19	59	8	₹ 279	₹ 303
9	19	59	8	₹ 297	₹ 360
10	22	67	10	₹ 330	₹ 411
11	22	67	10	₹ 393	₹ 510
12	26	76	12	₹ 429	₹ 552
13	26	76	12	₹ 558	₹ 687
14	26	76	12	₹ 630	₹ 777
15	32	88	16	₹ 669	₹ 831
16	32	88	16	₹ 690	₹ 981
17	32	88	16	₹ 840	₹ 1,185
18	32	88	16	₹ 852	₹ 1,335
19	32	88	16	₹ 891	₹ 1,401
20	38	101	20	₹ 1,059	₹ 1,674
21	38	101	20	₹ 1,230	₹ 1,902
22	38	101	20	₹ 1,230	₹ 1,902
23	38	101	20	₹ 1,383	₹ 2,382
24	45	116	25	₹ 1,593	₹ 2,442
25	45	116	25	₹ 1,593	₹ 2,442
26	45	116	25	₹ 1,590	₹ 2,412
27	45	116	25	₹ 1,728	₹ 2,583
28	45	116	25	₹ 1,794	₹ 2,730
29	45	116	25	₹ 2,037	₹ 3,045
30	45	116	25	₹ 2,277	₹ 3,363

<b>HSS End Mills as per BS-122</b>				<b>PL-51 (Price Per Piece in INR)</b>	
Flute Dia (inch)	Flute Length (mm)	Overall Length (mm)	Shank Dia (mm)	1X (M2)	2X (M35)
1/8	3/8	1+7/8	1/4	₹ 171	₹ 213
5/32	3/8	1+7/8	1/4	₹ 171	₹ 213
3/16	1/2	2	1/4	₹ 171	₹ 213
7/32	1/2	2	1/4	₹ 180	₹ 228
1/4	5/8	2+1/8	1/4	₹ 198	₹ 219
5/16	3/4	2+1/2	3/8	₹ 258	₹ 411
3/8	7/8	2+5/8	3/8	₹ 324	₹ 360
7/16	7/8	2+5/8	1/2	₹ 393	₹ 510
1/2	1	2+3/4	1/2	₹ 429	₹ 552
9/16	1+1/8	2+7/8	1/2	₹ 630	₹ 777
5/8	1+1/4	3+1/4	5/8	₹ 690	₹ 981
11/16	1+3/8	3+3/8	5/8	₹ 852	₹ 1,335
3/4	1+1/2	3+1/2	5/8	₹ 891	₹ 1,401
13/16	1+5/8	3+5/8	3/4	₹ 1,020	₹ 1,674
7/8	1+5/8	3+5/8	3/4	₹ 1,086	₹ 1,902
1	1+3/4	3+3/4	3/4	₹ 1,401	₹ 2,442
1-1/8	1+7/8	4+1/8	1	₹ 1,674	₹ 2,925
1-1/4	2	4+1/4	1	₹ 2,205	₹ 4,095



HSS Centre Drill as per BS 328				PL-51 (Price Per Piece in INR)			
B.S. No.	Pilot Dia (inch)	Body Dia (inch)	OAL	1X (M2)	2X (M35)	1X (M2) TINCO.	2X (M35) TINCO.
BS1	3/64"	1/8"	1-1/2"	₹ 141	₹ 213	₹ 241	₹ 313
BS2	1/16"	3/16"	1-3/4"	₹ 141	₹ 213	₹ 261	₹ 333
BS3	3/32"	1/4"	2"	₹ 144	₹ 222	₹ 304	₹ 382
BS4	1/8"	5/16"	2-1/4"	₹ 222	₹ 327	₹ 382	₹ 487
BS5	3/16"	7/16"	2-1/2"	₹ 339	₹ 489	₹ 499	₹ 649
BS6	1/4"	5/8"	3"	₹ 753	₹ 1,005	₹ 953	₹ 1,205
BS7	5/16"	3/4"	3-1/2"	₹ 1,170	₹ 1,563	₹ 1,490	₹ 1,883

HSS Centre Drill TYPE: A as per DIN 333				PL-51 (Price Per Piece in INR)	
Pilot Dia (mm)	Body Dia (mm)	OAL Max. (mm)	OAL Min. (mm)	1X (M2)	2X (M35)
1.25	3.15	33.5	29.5	₹ 141	₹ 219
1.6	4	37.5	33.5	₹ 141	₹ 219
2	5	42	38	₹ 153	₹ 228
2.5	6.3	47	43	₹ 153	₹ 228
3.15	8	52	48	₹ 225	₹ 333
4	10	59	53	₹ 297	₹ 411
5	12.5	66	60	₹ 426	₹ 636
6.3	16	74	68	₹ 774	₹ 960
8	20	83	77	₹ 1,230	₹ 1,584
10	25	103	97	₹ 1,992	₹ 2,358





**PL-51 ROHIT 1X Parallel Shank HSS M2 Drills DIN 338**  
**(Price Per Piece in INR)**

Dia (mm) IS5101, DIN338	List Price per pc	Pack Size	Dia (mm) IS5101, DIN338	List Price per pc	Pack Size	Dia (mm) IS5101, DIN338	List Price per pc	Pack Size
1.0	₹ 48	50	5.1	₹ 165	20	9.1	₹ 516	5
1.1	₹ 48	50	5.2	₹ 165	20	9.2	₹ 516	5
1.2	₹ 48	50	5.3	₹ 183	20	9.3	₹ 516	5
1.3	₹ 48	50	5.4	₹ 183	20	9.4	₹ 516	5
1.4	₹ 48	50	5.5	₹ 183	20	9.5	₹ 516	5
1.5	₹ 48	50	5.6	₹ 183	20	9.6	₹ 561	5
1.6	₹ 48	50	5.7	₹ 204	20	9.7	₹ 561	5
1.7	₹ 51	50	5.8	₹ 204	20	9.8	₹ 561	5
1.8	₹ 51	50	5.9	₹ 204	20	9.9	₹ 627	5
1.9	₹ 51	50	6.0	₹ 204	20	10.0	₹ 627	5
2.0	₹ 51	50	6.1	₹ 216	10	10.1	₹ 627	5
2.1	₹ 51	50	6.2	₹ 216	10	10.2	₹ 627	5
2.2	₹ 51	50	6.3	₹ 216	10	10.3	₹ 681	5
2.3	₹ 51	50	6.4	₹ 216	10	10.4	₹ 681	5
2.4	₹ 51	50	6.5	₹ 273	10	10.5	₹ 681	5
2.5	₹ 51	50	6.6	₹ 273	10	10.6	₹ 711	5
2.6	₹ 51	50	6.7	₹ 273	10	10.7	₹ 753	5
2.7	₹ 51	50	6.8	₹ 273	10	10.8	₹ 753	5
2.8	₹ 60	50	6.9	₹ 297	10	10.9	₹ 753	5
2.9	₹ 60	50	7.0	₹ 297	10	11.0	₹ 753	5
3.0	₹ 60	50	7.1	₹ 309	10	11.1	₹ 804	5
3.1	₹ 66	20	7.2	₹ 309	10	11.2	₹ 804	5
3.2	₹ 72	20	7.3	₹ 324	10	11.3	₹ 804	5
3.3	₹ 78	20	7.4	₹ 324	10	11.4	₹ 804	5
3.4	₹ 78	20	7.5	₹ 324	10	11.5	₹ 846	5
3.5	₹ 78	20	7.6	₹ 351	10	11.6	₹ 888	5
3.6	₹ 96	20	7.7	₹ 351	10	11.7	₹ 888	5
3.7	₹ 96	20	7.8	₹ 351	10	11.8	₹ 888	5
3.8	₹ 96	20	7.9	₹ 351	10	11.9	₹ 945	5
3.9	₹ 96	20	8.0	₹ 381	10	12.0	₹ 945	5
4.0	₹ 96	20	8.1	₹ 369	10	12.1	₹ 945	5
4.1	₹ 117	20	8.2	₹ 369	10	12.2	₹ 945	5
4.2	₹ 117	20	8.3	₹ 444	10	12.3	₹ 1,005	5
4.3	₹ 117	20	8.4	₹ 444	10	12.4	₹ 1,005	5
4.4	₹ 117	20	8.5	₹ 444	10	12.5	₹ 1,005	5
4.5	₹ 150	20	8.6	₹ 462	10	12.6	₹ 1,005	5
4.6	₹ 150	20	8.7	₹ 462	10	12.7	₹ 1,056	5
4.7	₹ 150	20	8.8	₹ 489	10	12.8	₹ 1,056	5
4.8	₹ 150	20	8.9	₹ 489	10	12.9	₹ 1,056	5
4.9	₹ 162	20	9.0	₹ 489	10	13.0	₹ 1,056	5
5.0	₹ 162	20						

\*Pack Size to be followed, loose pack orders will not be entertained



PL-51   HSS M2 Metric Coarse Pitch ISO529 Machine Taps   (Tolerance 6H , 6G) (Price Per Piece in INR)			
Size	St. Flute	Spiral Point	Spiral Flute
M 3 x 0.5	₹ 216	₹ 252	₹ 276
M 3.5 x 0.6	₹ 216	₹ 252	₹ 276
M 4 x 0.7	₹ 216	₹ 252	₹ 276
M 4.5 x 0.75	₹ 222	₹ 282	₹ 303
M 5 x 0.8	₹ 222	₹ 282	₹ 303
M 6 x 1	₹ 222	₹ 282	₹ 303
M 7 x 1	₹ 294	₹ 324	₹ 363
M 8 x 1.25	₹ 276	₹ 324	₹ 363
M 9 x 1.25	₹ 336	₹ 402	₹ 456
M10 x 1.5	₹ 336	₹ 402	₹ 456
M 11 x 1.5	₹ 441	₹ 645	₹ 705
M 12 x 1.75	₹ 543	₹ 645	₹ 705
M 14 x 2	₹ 681	₹ 843	₹ 993
M 16 x 2	₹ 774	₹ 843	₹ 993
M 18 x 2.5	₹ 1,104	₹ 1,164	₹ 1,380
M 20 x 2.5	₹ 1,335	₹ 1,464	₹ 1,842
M 22 x 2.5	₹ 1,509	₹ 1,743	₹ 1,923
M 24 x 3	₹ 1,791	₹ 1,941	₹ 2,085
M 27 x 3**	₹ 2,610		
M 30 x 3.5**	₹ 2,919		
M 33 x 3.5**	₹ 3,558		
M 36 x 4**	₹ 4,947		
M 39 x 4**	₹ 6,315		
M 42 x 4.5**	₹ 7,362		
M 45 x 4.5**	₹ 9,912		
M 48 x 5**	₹ 10,572		
M 52 x 5**	₹ 13,269		

\*\* Only manufactured against order with delivery time 8-12 weeks

PL-51   HSS M2 Metric Coarse Pitch ISO529 Machine Taps TIN Co.   (Tolerance 6H , 6G) (Price per pc in INR)			
Size	St. Flute	Spiral Point	Spiral Flute
M 3 x 0.5	₹ 333	₹ 375	₹ 402
M 3.5 x 0.6	₹ 333	₹ 375	₹ 402
M 4 x 0.7	₹ 333	₹ 375	₹ 402
M 4.5 x 0.75	₹ 360	₹ 429	₹ 456
M 5 x 0.8	₹ 360	₹ 429	₹ 456
M 6 x 1	₹ 360	₹ 429	₹ 456
M 7 x 1	₹ 486	₹ 522	₹ 567
M 8 x 1.25	₹ 465	₹ 522	₹ 567
M 9 x 1.25	₹ 534	₹ 612	₹ 675
M10 x 1.5	₹ 534	₹ 612	₹ 675
M 11 x 1.5	₹ 657	-	-
M 12 x 1.75	₹ 774	₹ 894	₹ 963
M 14 x 2	₹ 978	₹ 1,164	₹ 1,338
M 16 x 2	₹ 1,086	₹ 1,164	₹ 1,338
M 18 x 2.5	₹ 1,572	₹ 1,641	₹ 1,893
M 20 x 2.5	₹ 1,839	₹ 1,989	₹ 2,430
M 22 x 2.5	₹ 2,118	₹ 2,385	₹ 2,595
M 24 x 3	₹ 2,445	₹ 2,616	₹ 2,784
M 27 x 3**	₹ 3,741	-	-
M 30 x 3.5**	₹ 4,098	-	-