



MIRANDA TOOLS

Premium quality cutting tools

DORMER PRAMET

PRICE LIST

MT-0122



MIRANDA
Spark
Premium quality General Band saw blades

Hand & Power Hacksaws
Metal Cutting Carbon Bandsaws

MIRANDA
ZEDD+

HSS Bi-Metal Bandsaws

HSS Toolbits

MIRANDA
ZEDD

HSS Drills

HSS Endmills

MIRANDA
i-Drill

HSS Reamers

HSS Core Drills

MIRANDA
EDGE

HSS & TCT Annular Cutters

HSS Taps

MIRANDA
Maxx

Carbide Tipped Tools

Tungsten Carbide Rotary Burrs

MIRANDA
Maxx Pro

Solid Carbide Drills

Solid Carbide End Mills

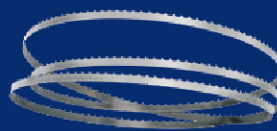

www.mirandatools.in
www.dormerpramet.com



Terms & Conditions

1. All Govt. taxes and levies are extra.
2. Delivery F.O.R Destination
3. This price list is effective from 01.01.2022 and super ceeds our previous Price list, Prices are subject to revision without any notice.
4. For unlisted intermediate sizes, the prices of next listed size in inch or mm will apply.
5. We also manufacture special products as per your requirements.
6. All MTO items required in minimum order value of Rs.10,000/- net or MOQ as per size whichever is higher.
7. If coating (TiN, TiCN, TiAlN) required while ordering will be charged extra if not included in price list. Minimum Order Value should be Rs.10,000 in each size or minimum order qty. as mentioned.

Jobber, Stub &	:	All sizes upto Dia 13.00mm to be ordered
Long Series Drills	:	In multiple of 10 Nos.
Centre Drills	:	Upto 1/2" (12.50 mm) to be ordered in multiple of 100 Nos.
Hand Hacksaws	:	To be ordered in multiple of 100Nos.
Power Hacksaws	:	Upto 18" to be ordered multiple of 10 Nos. Above 20" to be ordered in multiple of 5 Nos.
ToolBits	:	Upto 1/2" (12.50 mm) to be ordered in multiple of 10Nos.
Parallel Shank Endmills :		Upto 1/2" (12.50 mm) to be ordered in multiple of 10Nos

DESCRIPTION	PAGE NO.
SAWS	1 - 4
HAND & POWER HACKSAW BLADES	
METAL CUTTING BANDSAW & BIMETAL BANDSAW BLADES	
BI-METAL BANDSAW BLADE SPARK	
HSS TOOLBIT BLANKS	5 - 8
HSS TOOLBIT BLANKS, HSS FLAT (RECTANGULAR) & PARTING TOOLBITS	
ZEDD ++ TB SUPER	
HSS DRILLS	9 - 20
HSS PARALLEL SHANK JOBBER SERIES	
I-DRILL	
DRILL SET & HSS PARALLEL SHANK STUB SERIES, LONG & EXTRA LONG SERIES	
CENTRE DRILLS, HSS TAPER SHANK DRILLS, LONG & EXTRA LONG SERIES	
MASONRY DRILLS	
HSS ENDMILLS & REAMERS	21 - 23
HSS PARALLEL SHANK ENDMILLS, SLOT DRILLS, LONG SERIES	
ROUGHING ENDMILLS M42 & ANNULAR CUTTER	
HSS REAMERS & TAPER PIN REAMERS (TAPER 1 IN 50) & (TAPER 1 IN 48)	
CORE DRILLS	24 - 24
HIGH SPEED STEEL TAPER SHANK CORE DRILLS	
HSS & TCT ANNULAR CUTTERS	25 - 26
HSS & TCT ANNULAR CUTTER	
HSS TAPS	27 - 35
HSS TAPS COARSE PITCH & FINE PITCH	
HSS HAND TAPS - BSW,BSF,UNC,UNF,BSCy, BA & PIPE TAPS	
HSS NIB TAPS & UN TAPS	
HSS GROUND THREAD HAND TAPS - COARSE PITCH - HELICOIL	
HIGH PERFORMANCE PLATINUM CUT (EDGE)	
TUNGSTEN CARBIDE TIPPED TOOLS	36 - 42
STRAIGHT ROUND & GROOVING TOOLS, STRAIGHT THREADING TOOLS, INTERNAL & EXTERNAL THREADING TOOLS, THREADING TOOLS WITH "V" PROFILE	
TUNGSTEN CARBIDE ROTARY BURRS	43 - 45
CONICAL,CYLINDRICAL RADIUS END, CYLINDRICAL FLAME,CONE,OVAL,RIM,BALL, TREE POINTED END,TREE RADIUS END, INVERTED CONE,SET OF FIVE PIECES	
SOLID CARBIDE DRILLS & ENDMILLS	46 - 48
STRAIGHT SHANK SOLIDE CARBIDE DRILLS (JOBBER & STUB SERIES)	
2/4 FLUTE CENTRE CUTTING UNCOATED & TIALN COATED,BALL NOSE ENDMILLS,	
LONG /EXTRA LONG LENGTH 4 FLUTE CENTRE CUTTING TIALN COATED	
SUGGESTED SPEED AND FEED DATA DOR SOLID CARBIDE ENDMILLS & DRILLS	49

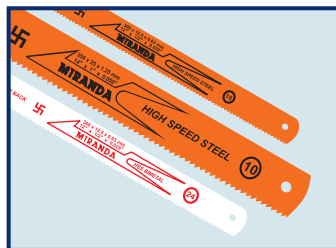

SAWS HAND HACKSAW BLADES

NOMINAL SIZE (Length X Width X Thickness)		HSS - ALL HARD		HSS - BIMETAL		LOW ALLOY
Inches	Millimeters	Teeth Per Inch (TPI)	HSS Regular Rs. / Piece	Teeth Per Inch (TPI)	HSS BIMETAL Rs./Piece	Rs./Piece
12 x ½ x 0.025 (23 G)	300 x 12.5 x 0.63	14 18 24 32	76.65	14 18 24 32	66.68	7.35

POWER HACKSAW BLADES

NOMINAL SIZE (Length X Width X Thickness)		HSS - ALL HARD		HSS - BIMETAL		LOW ALLOY
Inches	Millimeters	Teeth Per Inch (TPI)	HSS Regular Rs. / Piece	Teeth Per Inch (TPI)	HSS BIMETAL Rs./Piece	Rs./Piece
12 x 1 x 0.050 (18 G)	300 x 25 x 1.25	10* 14	352	10 14	270	33
14 x 1 x 0.050 (18 G)	350 x 25 x 1.25	6 10* 14*	396	6 10 14	307	39
16 x 1 x 0.050 (18 G)	400 x 25 x 1.25	10 14	523	10 14	423	44
17 x 1 x 0.050 (18 G)	425 x 25 x 1.25	10 14	589	10 14	459	-
18 x 1 x 0.050 (18 G)	450 x 25 x 1.25	10* 14	597	10 14	470	56
14 x 1¼ x 0.062 (16 G)	350 x 32 x 1.60	6* 10*	674	6 10	515	54
16 x 1¼ x 0.062 (16 G)	400 x 32 x 1.60	6* 10*	777	6 10	589	62
17 x 1¼ x 0.062 (16 G)	425 x 32 x 1.60	6 10	837	6 10	664	-
18 x 1¼ x 0.062 (16 G)	450 x 32 x 1.60	6* 10*	864	6 10	674	72
18 x 1¼ x 0.080 (14 G)	450 x 32 x 2.00	4 6 10	1075	-	-	-
18 x 1½ x 0.062 (16 G)	450 x 40 x 1.60	6* 10*	1152	-	-	90
18 x 1½ x 0.080 (14 G)	450 x 40 x 2.00	4 6* 10	1274	6	975	-
20 x 1½ x 0.080 (14 G)	500 x 40 x 2.00	4 6 10	1415	6	1,075	-
21 x 1½ x 0.080 (14 G)	525 x 40 x 2.00	4 6* 10	1495	4 6	1,194	-
22 x 1½ x 0.080 (14 G)	550 x 40 x 2.00	4 6	1563	4 6	1,298	-
24 x 1½ x 0.080 (14 G)	600 x 40 x 2.00	4 6* 10	1716	4 6	1,400	-
24 x 1½ x 0.100 (12 G)	600 x 40 x 2.50	4 6	2036	-	-	-
28 x 1½ x 0.100 (12 G)	700 x 40 x 2.50	4 6	2455	-	-	-
30 x 1½ x 0.100 (12 G)	750 x 40 x 2.50	4 6	2732	-	-	-
24 x 2 x 0.080 (14 G)	600 x 50 x 2.00	4 6	2406	-	-	-
24 x 2 x 0.100 (12 G)	600 x 50 x 2.50	4 6	2847	4 6	2,165	-
28 x 2 x 0.100 (12 G)	700 x 50 x 2.50	4 6	3318	4 6	2,495	-
30 x 2 x 0.100 (12 G)	750 x 50 x 2.50	4 6	3699	4 6	2,876	-
32 x 2 x 0.100 (12 G)	800 x 50 x 2.50	4 6	3790	4 6	2,946	-
36 x 2 x 0.100 (12 G)	900 x 50 x 2.50	4 6	4469	4 6	3,470	-
32 x 2½ x 0.100 (12 G)	800 x 55 x 2.50	-	-	4	3,703	-

- Width specification are approximate and depend upon availability of RM steel.
- Any other dimensional variability may occur due to RM Steel availability, but adequate rigidity in cutting is assured.

METAL CUTTING BANDSAW BLADES

NOMINAL SIZE (WIDTH X THICKNESS)		TEETH PER INCH (TPI)		Price For 30.5 Mtrs. long Roll
Inches	Millimeters	Racker Set	Wavy Set	Rs./ Roll
1/4 x 0.025 (23 G)	6.35 x 0.63	10 14	18 24	2179
3/8 x 0.025 (23 G)	9.53 x 0.63	6 8 10 14	18 24	1494
1/2 x 0.025 (23 G)	12.70 x 0.63	6 8 10 14	18 24	1806
1/2 x 0.025 (23 G) (SKIP)	12.70 x 0.63	6		1926
5/8 x 0.032 (21 G)	15.88 x 0.80	6 8 10 14	18 24	2347
3/4 x 0.032 (21 G)	19.05 x 0.80	4 6 8 10 14	18 24	2466
3/4 x 0.032 (21 G) (SKIP)	19.05 x 0.80	6		2756
1 x 0.035 (20 G)	25.40 x 0.90	4 6 8 10 14	18 24	3278

METAL CUTTING BANDSAW WELDED COILS

NOMINAL SIZE (WIDTH X THICKNESS X LENGTH)		TEETH PER INCH (TPI)		PRICE
Inches	Millimeters	Racker Set	Wavy Set	Rs./ Loop
3/4 x 0.032 (21 G) x 8' 3"	19.05 x 0.80 x 2515	4 6 8* 10* 14	18 24	273
3/4 x 0.032 (21 G) x 9' 10"	19.05 x 0.80 x 2997	4 6 8 10 14	18 24	310
3/4 x 0.032 (21 G) x 11' 7½"	19.05 x 0.80 x 3544	4 6 8 10 14	18 24	358

• Welded Coils (Loops) are available in any size, Prices given are for three popular sizes.

BIMETAL BANDSAW BLADES

GRADE	SIZE	TEETH (TPI)	PRICE RS. / METER
FURIA - N/VN (M 42)	13X0.65	8,10,14,18,24 / 6/10,8/12,10/14	627
	13X0.90	6, 8, 10, 14, 18 / 5/8,6/10,8/12,10/14	677
	20X0.90*	6,8,10,14 / 4/6, 5/8, 6/10, 8/12, 10/14	701
	27X0.90	4,6,8,10,14 / 3/4, 4/6, 5/8, 6/10, 8/12, 10/14	723
	34X1.10	6 / 3/4, 4/6, 5/8, 6/10	767
	41X1.30	6 / 3/4, 4/6	1081
FURIA - VI (M 42)	27X0.90*	2/3, 3/4, 4/6, 5/8, 6/10	723
	34X1.10	2/3, 3/4, 4/6	767
	41X1.30	1.2/2, 2/3, 3/4, 4/6	1081
	54X1.60	0.75/1.2, 1.2/2, 2/3, 3/4, 4/6	1707
	67X1.60	0.75/1.2, 1.2/2, 2/3, 3/4	2782
ALUMINA-CI (M 42)	20X0.90	3	796
	27X0.90	2, 3	820
	34X1.10	1.2, 2, 3	870
	41X1.30	1.2, 2	1342
	27X0.90	3/4, 4/6	820
KATANA-VX (M 42)	34x1.10	2/3, 3/4	870
	41x1.30	1.2/2, 2/3, 3/4	1283
	54x1.60	0.75/1.25, 1.2/2, 2/3	1946
	67x1.60	0.75/1.25, 1.2/2, 2/3	3163
TITAN-VX (M 51)	27x0.90	2/3, 3/4, 4/6	916
	34x1.10	2/3, 3/4, 4/6	973
	41x1.30	1.2/2, 2/3, 3/4	1514
	54x1.60	1.2/2, 2/3	2318

* Length & TPI of Bimetal Loop as per requirement.

M

MIRANDA TOOLS

Premium quality cutting tools

DORMER PRAMET

**Premium Bi-Metal
Band Saw Blade
(M-42)**

MIRANDA
spark
Premium quality Bimetal Band saw blades

New Launch



MIRANDA *spark* VI M-42





PREMIUM BI-METAL BAND SAW BLADE (M-42)

PREMIUM BIMETAL BANDSAW BLADE_SPARK			
GRADE	SIZE	TEETH (TPI)	PRICE / Metre
Spark VN	20X0.9	4/6, 5/8, 6/10, 8/12, 10/14	736
	27X0.9	4/6, 5/8, 6/10, 8/12, 10/14	760
	34X1.1	5/8, 6/10	820
Spark VI	27X0.9	2/3, 3/4, 4/6, 5/8, 6/10	760
	34X1.1	2/3, 3/4, 4/6,	820
	41X1.3	2/3, 3/4, 4/6	1157

TYPE VI		APPLICATIONS
TYPE VN		
		<ul style="list-style-type: none"> ● Steel ● Cast Iron ● Brass ● Aluminium ● Non - ferrous metal ● Forged Industries

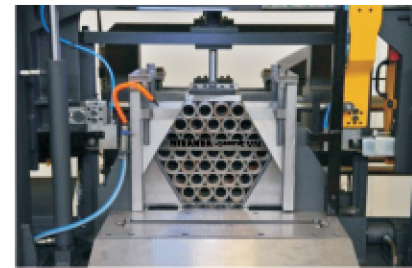

SPARK VI ideal for :

- Steel with low carbon content
- Cr-Ni alloys
- Large cross sections for serial cuts in automatic operation
- Maximize Tooth Penetration
- High Rake Angle
- Increase in Efficiency By 30%

SPARK VN ideal for :

- Low alloyed materials
- Small and medium cross section of solids tubes & profiles
- Structural materials
- Non-Ferrous metals

HSS TOOLBIT BLANKS



NOMINAL SIZE			GRADES						PKT. QTY.
MM	INCH	EQUIVALENT MM	ZEDD SQ. Price Each Rs.	S100 M35 SQ./RD Price Each Rs.	S200 M42 SQ./RD Price Each Rs.	S400 T42 SQ./RD Price Each Rs.	S400E M35 SQ./RD Price Each Rs.	S500 T42 SQ./RD Price Each Rs.	
-	3/32 x 2.1/2	2.38 x 63.50	112	247	347	366	291	389	10
-	3/32 x 3	2.38 x 76.20	130	399	559	586	469	622	10
3 x 75	1/8 x 3	3.18 x 76.20	130	273	385	406	320	423	10
3 x 100	1/8 x 4	3.18 x 101.60	171	493	709	744	585	773	10
4 x 75	5/32 x 3	3.97 x 76.20	130	277	395	414	327	424	10
4 x 100	5/32 x 4	3.97 x 101.60	175	429	613	644	510	661	10
5 x 75	3/16 x 3	4.76 x 76.20	112	219	287	301	256	311	10
5 x 100	3/16 x 4	4.76 x 101.60	147	322	419	440	380	461	10
5 x 150	3/16 x 6	4.76 x 152.40	228	582	893	943	682	944	10
6 x 75	1/4 x 3	6.35 x 76.20	128	277	385	406	327	424	10
6 x 100	1/4 x 4	6.35 x 101.60	150	376	511	539	440	561	10
6 x 150	1/4 x 6	6.35 x 152.40	216	615	836	881	725	914	10
6 x 200	1/4 x 8	6.35 x 203.20	308	1,021	1,414	1,488	1,197	1,566	10
8 x 75	5/16 x 3	7.94 x 76.20	142	363	494	523	429	556	10
8 x 100	5/16 x 4	7.94 x 101.60	184	500	679	712	588	760	10
8 x 150	5/16 x 6	7.94 x 152.40	304	798	1,090	1,146	944	1,216	10
8 x 200	5/16 x 8	7.94 x 203.20	386	1,137	1,541	1,625	1,341	1,733	10
-	3/8 x 3	9.53 x 76.20	178	423	586	621	495	659	10
-	3/8 x 4	9.53 x 101.60	216	565	775	817	667	887	10
-	3/8 x 6	9.53 x 152.40	336	892	1,248	1,312	1,054	1,401	10
-	3/8 x 8	9.53 x 203.20	455	1,270	1,770	1,865	1,490	1,987	10
-	3/8 x 10	9.53 x 254.00	587	1,683	2,344	2,467	1,978	2,631	10
10 x 75	-	-	197	461	640	672	541	720	10
10 x 100	-	-	234	615	858	903	723	963	10
10 x 150	-	-	362	963	1,344	1,416	1,137	1,505	10
10 x 200	-	-	507	1,358	1,889	1,988	1,599	2,120	10
10 x 250	-	-	639	1,793	2,496	2,626	2,101	2,796	10
12 x 75	1/2 x 3	12.70 x 76.20	267	668	958	1,007	788	1,049	10
12 x 100	1/2 x 4	12.70 x 101.60	336	892	1,249	1,314	1,054	1,406	10
12 x 150	1/2 x 6	12.70 x 152.40	512	1,373	1,958	2,065	1,617	2,159	10
12 x 200	1/2 x 8	12.70 x 203.20	672	1,919	2,733	2,876	2,258	3,010	10
12 x 250	1/2 x 10	12.70 x 254.00	1,024	2,687	3,757	3,960	3,161	4,201	10
14 x 100	9/16 x 4	14.29 x 101.60	413	1,146	1,541	1,625	1,352	1,733	1
14 x 150	9/16 x 6	14.29 x 152.40	635	1,733	2,327	2,448	2,032	2,608	1
14 x 200	9/16 x 8	14.29 x 203.20	871	2,405	3,237	3,407	2,828	3,626	1
16 x 100	5/8 x 4	15.88 x 101.60	531	1,470	2,101	2,213	1,734	2,302	1
16 x 150	5/8 x 6	15.88 x 152.40	783	2,210	3,078	3,237	2,596	3,448	1
16 x 200	5/8 x 8	15.88 x 203.20	1,058	3,020	4,314	4,543	3,555	4,720	1
-	3/4 x 4	19.05 x 101.60	734	2,045	2,885	3,037	2,404	3,202	1
-	3/4 x 6	19.05 x 152.40	1,073	3,061	4,233	4,459	3,605	4,797	1
-	3/4 x 8	19.05 x 203.20	1,468	4,109	5,801	6,106	4,831	6,431	1
20 x 100	-	-	802	2,228	3,147	3,314	2,619	3,488	1
20 x 150	-	-	1,168	3,335	4,716	4,967	3,929	5,233	1
20 x 200	-	-	1,596	4,445	6,288	6,621	5,238	6,972	1
25 x 150	1 x 6	25.40 x 152.40	1,806	5,084	7,102	7,479	5,980	7,947	1
25 x 200	1 x 8	25.40 x 203.20	2,456	6,778	9,468	9,967	7,974	10,596	1

(Square Toolbit blanks are with bevelled ends)

- ZEDD = (HSS With 0% Cobalt) (62-65 HRc)
- S100 = M35 (HSS With 5% Cobalt) (63-65 HRc)
- S200 = M42 (HSS With 8% Cobalt) (65-68 HRc)
- S400 = T42 (HSS With 10% Cobalt) (64-67 HRc)
- S400E = M35 with Cryogenic (Ultra Low) Heat Treatment (64-67 HRc)
- S500 = T42 with Cryogenic (Ultra Low) Heat Treatment (65-69 HRc)

HSS FLAT (RECTANGULAR) TOOLBIT BLANKS

NOMINAL SIZE			GRADES		PKT. QTY.
MM	INCH	EQUIVALENT MM	MARK III	T42	
			Price Each Rs.	Price Each Rs.	
3 x 20 x 150	1/8 x 3/4 x 6	3.18 x 19.05 x 152.40	842	1,314	10
3 x 25 x 150	1/8 x 1 x 6	3.18 x 25.40 x 152.40	1,202	1,879	10
5 x 25 x 150	3/16 x 1 x 6	4.76 x 25.40 x 152.40	1,321	2,305	10
6 x 12 x 100	1/4 x 1/2 x 4	6.35 x 12.70 x 101.60	508	793	10
6 x 12 x 150	1/4 x 1/2 x 6	6.35 x 12.70 x 152.40	777	1,221	10
6 x 16 x 150	1/4 x 5/8 x 6	6.35 x 15.88 x 152.40	926	1,501	10
6 x 20 x 150	1/4 x 3/4 x 6	6.35 x 19.05 x 152.40	1,098	1,720	10
6 x 25 x 150	1/4 x 1 x 6	6.35 x 25.40 x 152.40	1,341	2,096	10
10 x 12 x 100	3/8 x 1/2 x 4	9.53 x 12.70 x 101.60	763	1,196	10
10 x 16 x 100	3/8 x 5/8 x 4	9.53 x 15.88 x 101.60	847	1,328	10
10 x 16 x 150	3/8 x 5/8 x 6	9.53 x 15.88 x 152.40	1,323	2,065	10
10 x 20 x 150	3/8 x 3/4 x 6*	9.53 x 19.05 x 152.40	1,525	2,379	10
10 x 25 x 150	3/8 x 1 x 6	9.53 x 25.40 x 152.40	2,614	4,084	10
12 x 16 x 150	1/2 x 5/8 x 6	12.70 x 15.88 x 152.40	1,631	2,896	1
12 x 20 x 150	1/2 x 3/4 x 6	12.70 x 19.05 x 152.40	1,805	3,202	1
12 x 25 x 150	1/2 x 1 x 6	12.70 x 25.40 x 152.40	2,367	3,707	1
16 x 20 x 150	5/8 x 3/4 x 6	15.88 x 19.05 x 152.40	2,458	4,199	1
20 x 25 x 150	3/4 x 1 x 6	19.05 x 25.40 x 152.40	3,461	6,642	1

• Mark III - M35 (HSS with 5% Cobalt) (63-66 HRC), T42 (HSS with 10% Cobalt)

HSS PARTING TOOLBITS

NOMINAL SIZE		GRADES		PKT. QTY.
INCH	EQUIVALENT MM	MARK II	T42	
		Price Each Rs.	Price Each Rs.	
3/32 x 1/2 x 4	2.38 x 12.70 x 101.60	665	1,166	10
3/32 x 5/8 x 5	2.38 x 15.88 x 127.00	833	1,533	10
1/8 x 3/4 x 6*	3.18 x 19.05 x 152.40	1,062	1,882	10
1/8 x 7/8 x 6	3.18 x 22.23 x 152.40	1,243	2,298	10
3/16 x 1 x 6	4.76 x 25.40 x 152.40	1,545	2,633	10

• Mark II - M2 (HSS with 0% Cobalt) (62-65 HRC), T42 (HSS with 10% Cobalt)

ToolBit Terms - General Features

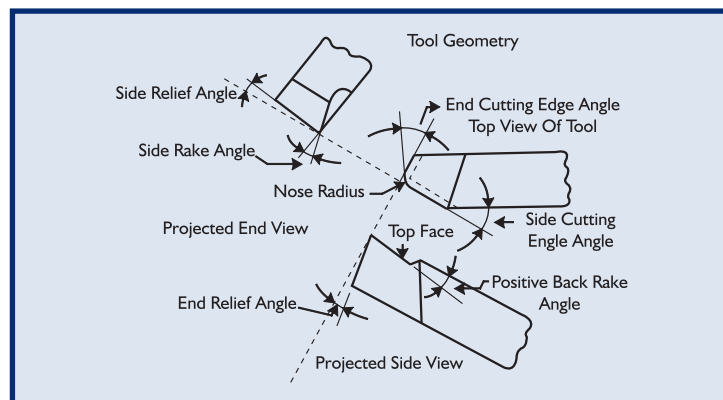



MIRANDA TOOLS
Premium quality cutting tools

DORMER PRAMET

HSS TOOL BIT BLANK



New Launch

(1/4"x4") 6.35x101.60 mm

(3/8"x4") 9.53x101.60mm

MIRANDA ZEDD PLUS

MIRANDA ZEDD PLUS





HSS TOOL BIT BLANK

PRODUCT CODE	DESC	PRIZE PER PICE	PACKING QTY.
MIRTSAI05CI0505100	TOOLBIT BLANK SQ 3/16"X4" H SS ZEDD+	155	10
MIRTSAI05CI0505150	TOOLBIT BLANK SQ 3/16"X6" H SS ZEDD+	240	10
MIRTSAI05CI0606075	TOOLBIT BLANK SQ 1/4"X3" ZEDD +	135	10
MIRTSAI05CI0606100	TOOLBIT BLANK SQ 1/4"X4" ZEDD +	157	10
MIRTSAI05CI0606150	TOOLBIT BLANK SQ 1/4"X6" ZEDD +	226	10
MIRTSAI05CI0808075	TOOLBIT BLANK SQ 5/16"X3" H SS ZEDD+	149	10
MIRTSAI05CI0808100	TOOLBIT BLANK SQ 5/16"X4" H SS ZEDD+	194	10
MIRTSAI05CI0808150	TOOLBIT BLANK SQ 5/16"X6" H SS ZEDD+	319	10
MIRTSAI05CI1010075	TOOLBIT BLANK SQ 3/8"X3" ZEDD +	186	10
MIRTSAI05CI1010100	TOOLBIT BLANK SQ 3/8"X4" ZEDD +	226	10
MIRTSAI05CI1010150	TOOLBIT BLANK SQ 3/8"X6" ZEDD +	353	10
MIRTSAI05CI1010200	TOOLBIT BLANK SQ 3/8"X8" ZEDD +	478	10
MIRTSAI05CI1212075	TOOLBIT BLANK SQ 1/2"X3" ZEDD +	280	10
MIRTSAI05CI1212100	TOOLBIT BLANK SQ 1/2"X4" ZEDD +	353	10
MIRTSAI05CI1212150	TOOLBIT BLANK SQ 1/2"X6" ZEDD +	538	10
MIRTSAI05CI1212200	TOOLBIT BLANK SQ 1/2"X8" ZEDD +	704	10
MIRTSAI05CI1616100	TOOLBIT BLANK SQ 5/8"X4" ZEDD +	559	10
MIRTSAI05CI1616150	TOOLBIT BLANK SQ 5/8"X6" ZEDD +	822	10
MIRTSAI05CI2020150	TOOLBIT BLANK SQ 3/4"X6" ZEDD +	1,127	10
MIRTSAI05CI2525150	TOOLBIT BLANK SQ 1"X6" ZEDD +	1,897	10
MIRTSAI05CI2525200	TOOLBIT BLANK SQ 1"X8" ZEDD +	2,579	10

FEATURE

- Superior Performance
- Improved Wear Resistance
- Extended Pointing Frequency
- Special Surface Treatment
- Excellent Performance on Critical Application



MIRANDA TOOLS

Premium quality cutting tools

DORMER PRAMET



MIRANDA Gold Drills



MIRANDA Super Drills

MIRANDA Gold Drills

SIZE RANGE : GOLD JOBBER DRILL

- Metric size : 1.0 mm to 20.0 mm
- Inch size : 3/64" to 25/32"

APPLICATION :

- Suitable for non ferrous metals.
- Suitable for aluminium alloy & Cast steel material.
- Suitable for material up to 25HRc.
- Suitable for general application

MIRANDA Super Drills

SIZE RANGE : SUPER JOBBER DRILL

- Metric size : 1.00 mm to 16.0 mm
- Inch size : 3/64" to 5/8"

APPLICATION :

- Drilling alloy steel up to 28-35 HRc.
- Suitable for drilling all types of stainless steel materials.
- Suitable for forged steel components.
- All Titanium alloys, Hastelloy, Inconel and Heat Resistant steels.



HSS DRILLS

HSS PARALLEL SHANK JOBBER SERIES (IS : 5101 - 1991)



SIZES			PRICE Rs. / 10 Nos.			SIZES			PRICE Rs. / 10 Nos.		
MM	INCH	DG	STD JOBBER DRILLS M2	GOLD JOBBER DRILLS M2	SUPER JOBBER DRILLS M35	MM	INCH	DG	STD JOBBER DRILLS M2	GOLD JOBBER DRILLS M2	SUPER JOBBER DRILLS M35
1.00	-	-	385	427	549	2.90	-	-	414	458	589
1.02	-	60	385	427	549	2.95	-	32	414	458	589
1.04	-	59	385	427	549	3.00	-	-	414	458	589
1.07	-	58	385	427	549	3.05	-	31*	542	602	771
1.09	-	57	385	427	549	3.10	-	-	542	602	771
1.10	-	-	385	427	549	3.17	1/8	-	542	602	771
1.18	-	56	385	427	549	3.20	-	-	556	617	792
1.19	3/64	-	385	427	549	3.26	-	30	556	617	792
1.20	-	-	385	427	549	3.30	-	-	556	617	792
1.30	-	-	385	427	549	3.40	-	-	556	617	792
1.32	-	55	385	427	549	3.45	-	29	556	617	792
1.40	-	54	385	427	549	3.50	-	-	556	617	792
1.50	-	-	385	427	549	3.57	9/64	28	556	617	792
1.51	-	53	385	427	549	3.60	-	-	829	919	1182
1.59	1/16	-	385	427	549	3.66	-	27	829	919	1182
1.60	-	-	385	427	549	3.70	-	-	829	919	1182
1.61	-	52	403	447	575	3.73	-	26	829	919	1182
1.70	-	51	403	447	575	3.80	-	25	829	919	1182
1.78	-	50	403	447	575	3.86	-	24	829	919	1182
1.80	-	-	403	447	575	3.90	-	-	829	919	1182
1.85	-	49	403	447	575	3.91	-	23	829	919	1182
1.90	-	-	403	447	575	3.97	5/32	-	829	919	1182
1.93	-	48	403	447	575	3.99	-	22	829	919	1182
1.98	5/64	-	403	447	575	4.00	-	-	829	919	1182
1.99	-	47	403	447	575	4.04	-	21	999	1,107	1423
2.00	-	-	403	447	575	4.09	-	20	999	1,107	1423
2.06	-	46	403	447	575	4.10	-	-	999	1,107	1423
2.08	-	45	403	447	575	4.20	-	-	999	1,107	1423
2.10	-	-	403	447	575	4.22	-	19	999	1,107	1423
2.18	-	44	403	447	575	4.30	-	18	999	1,107	1423
2.20	-	-	403	447	575	4.37	11/64	-	999	1,107	1423
2.26	-	43	403	447	575	4.39	-	17	999	1,107	1423
2.30	-	-	403	447	575	4.40	-	-	999	1,107	1423
2.37	-	42	403	447	575	4.50	-	16	1,312	1,457	1870
2.38	3/32	-	403	447	575	4.57	-	15	1,312	1,457	1870
2.40	-	-	403	447	575	4.60	-	-	1,312	1,457	1870
2.44	-	41	403	447	575	4.62	-	14	1,312	1,457	1870
2.49	-	40	403	447	575	4.70	-	13	1,312	1,457	1870
2.50	-	-	403	447	575	4.76	3/16	-	1,312	1,457	1870
2.53	-	39	403	447	575	4.80	-	12	1,312	1,457	1870
2.58	-	38	403	447	575	4.85	-	11	1,441	1,599	2053
2.60	-	-	403	447	575	4.90	-	-	1,441	1,599	2053
2.64	-	37*	403	447	575	4.92	-	10	1,441	1,599	2053
2.70	-	-	403	447	575	4.98	-	9	1,441	1,599	2053
2.71	-	36	403	447	575	5.00	-	-	1,441	1,599	2053
2.78	7/64	-	403	447	575	5.06	-	8	1,441	1,599	2053
2.79	-	35	414	458	589	5.10	-	-	1,441	1,599	2053
2.80	-	-	414	458	589	5.11	-	7	1,441	1,599	2053
2.82	-	34	414	458	589	5.16	13/64	-	1,441	1,599	2053
2.87	-	33	414	458	589	5.18	-	6	1,441	1,599	2053

HSS DRILLS

HSS PARALLEL SHANK JOBBER SERIES (IS : 5101 - 1991)

SIZES			PRICE Rs. / 10 Nos.			SIZES			PRICE Rs. / 10 Nos.		
MM	INCH	DG	STD JOBBER DRILLS	GOLD JOBBER DRILLS	SUPER JOBBER DRILLS	MM	INCH	DG	STD JOBBER DRILLS	GOLD JOBBER DRILLS	SUPER JOBBER DRILLS
5.20*	-	-	1,441	1,599	2,053	9.13	23/64	-	4,429	4,919	6,319
5.22	-	5	1,556	1,728	2,221	9.20	-	-	4,429	4,919	6,319
5.30*	-	-	1,556	1,728	2,221	9.30	-	-	4,429	4,919	6,319
5.31	-	4	1,556	1,728	2,221	9.34	-	U	4,429	4,919	6,319
5.40*	-	-	1,556	1,728	2,221	9.40*	-	-	4,429	4,919	6,319
5.41	-	3	1,556	1,728	2,221	9.50*	-	-	4,429	4,919	6,319
5.50*	-	-	1,556	1,728	2,221	9.52	3/8*	-	5,040	5,596	7,190
5.56	7/32*	-	1,556	1,728	2,221	9.60	-	-	5,040	5,596	7,190
5.60	-	-	1,556	1,728	2,221	9.70	-	-	5,040	5,596	7,190
5.61	-	2	1,733	1,925	2,472	9.80	-	-	5,040	5,596	7,190
5.70	-	-	1,733	1,925	2,472	9.90	-	-	5,618	6,236	8,011
5.79	-	1	1,733	1,925	2,472	9.92	25/64	-	5,618	6,236	8,011
5.80*	-	-	1,733	1,925	2,472	10.00*	-	-	5,618	6,236	8,011
5.90*	-	-	1,733	1,925	2,472	10.10*	-	-	5,618	6,236	8,011
5.95	15/64*	-	1,733	1,925	2,472	10.20*	-	-	5,618	6,236	8,011
6.00*	-	-	1,733	1,925	2,472	10.30*	-	-	6,113	6,785	8,715
6.04	-	B	1,899	2,110	2,708	10.32	13/32*	-	6,113	6,785	8,715
6.10*	-	-	1,899	2,110	2,708	10.40	-	-	6,113	6,785	8,715
6.15	-	C	1,899	2,110	2,708	10.50*	-	-	6,113	6,785	8,715
6.20*	-	-	1,899	2,110	2,708	10.60	-	-	6,113	6,785	8,715
6.30*	-	-	1,899	2,110	2,708	10.70	-	-	6,460	7,173	9,212
6.35	1/4*	E	1,899	2,110	2,708	10.72	27/64	-	6,460	7,173	9,212
6.40	-	-	1,899	2,110	2,708	10.80*	-	-	6,460	7,173	9,212
6.50*	-	-	2,425	2,692	3,459	10.90	-	-	6,460	7,173	9,212
6.60*	-	-	2,425	2,692	3,459	11.00*	-	-	6,460	7,173	9,212
6.63	-	G	2,425	2,692	3,459	11.10*	-	-	7,211	8,003	10,282
6.70*	-	-	2,425	2,692	3,459	11.11	7/16*	-	7,211	8,003	10,282
6.75	17/64*	H	2,425	2,692	3,459	11.20	-	-	7,211	8,003	10,282
6.80*	-	-	2,425	2,692	3,459	11.30	-	-	7,211	8,003	10,282
6.90*	-	-	2,653	2,943	3,782	11.40	-	-	7,211	8,003	10,282
7.00*	-	J	2,653	2,943	3,782	11.50*	-	-	7,597	8,432	10,833
7.10	-	-	2,653	2,943	3,782	11.51	29/64	-	7,597	8,432	10,833
7.14	9/32*	K	2,653	2,943	3,782	11.60	-	-	7,597	8,432	10,833
7.20	-	-	2,653	2,943	3,782	11.70	-	-	7,597	8,432	10,833
7.30*	-	-	2,803	3,113	3,999	11.80*	-	-	7,597	8,432	10,833
7.40	-	-	2,803	3,113	3,999	11.90	-	-	8,120	9,017	11,580
7.50*	-	-	2,803	3,113	3,999	11.91	15/32	-	8,120	9,017	11,580
7.54	19/64*	-	3,044	3,379	4,342	12.00*	-	-	8,120	9,017	11,580
7.60	-	-	3,045	3,379	4,342	12.10	-	-	8,120	9,017	11,580
7.70	-	-	3,045	3,379	4,342	12.20	-	-	8,120	9,017	11,580
7.80*	-	-	3,045	3,379	4,342	12.30	31/64	-	8,612	9,561	12,280
7.90*	-	-	3,327	3,693	4,744	12.40	-	-	8,612	9,561	12,280
7.94	5/16*	-	3,327	3,693	4,744	12.50*	-	-	8,612	9,561	12,280
8.00*	-	-	3,327	3,693	4,744	12.60	-	-	8,612	9,561	12,280
8.03	-	O	3,327	3,693	4,744	12.70	1/2*	-	9,088	10,088	12,961
8.10*	-	-	3,327	3,693	4,744	12.80	-	-	9,088	10,088	12,961
8.20*	-	-	3,327	3,693	4,744	12.90	-	-	9,088	10,088	12,961
8.30	-	-	4,024	4,467	5,738	13.00*	-	-	9,088	10,088	12,961
8.33	21/64*	-	4,024	4,467	5,738	13.10	33/64	-	11,308	12,553	16,127
8.40	-	-	4,024	4,467	5,738	13.20	-	-	11,308	12,553	16,128
8.50*	-	-	4,024	4,467	5,738	13.30	-	-	11,308	12,553	16,128
8.60*	-	-	4,024	4,467	5,738	13.40	-	-	11,308	12,553	16,128
8.70*	-	-	4,024	4,467	5,738	13.49	17/32*	-	12,026	13,351	17,152
8.73	11/32*	-	4,291	4,763	6,119	13.50*	-	-	12,026	13,351	17,152
8.80	-	-	4,291	4,763	6,119	13.60	-	-	12,026	13,351	17,152
8.90	-	-	4,291	4,763	6,119	13.70	-	-	12,026	13,351	17,152
9.00*	-	-	4,291	4,763	6,119	13.80	-	-	12,026	13,351	17,152
9.10	-	-	4,429	4,919	6,319	13.89	35/64	-	13,060	14,500	18,626

SIZES			PRICE Rs. / 10 Nos.		
MM	INCH	DG	STD JOBBER DRILLS	GOLD JOBBER DRILLS	SUPER JOBBER DRILLS
13.90	-	-	13,060	14,499	18,626
14.00*	-	-	13,060	14,499	18,626
14.25	-	-	13,060	14,499	18,626
14.29	9/16	-	13,690	15,197	19,525
14.50*	-	-	14,740	15,197	19,525
14.68	37/64	-	14,740	16,363	21,020
14.75	-	-	14,740	16,363	21,020
15.00*	-	-	14,740	16,363	21,020
15.08	19/32	-	14,740	16,363	21,020
15.25	-	-	14,740	16,363	21,020

SIZES			PRICE Rs. / 10 Nos.		
MM	INCH	DG	STD JOBBER DRILLS	GOLD JOBBER DRILLS	SUPER JOBBER DRILLS
15.50*	-	-	16,000	17,760	22,815
15.75	-	-	16,000	17,760	22,815
15.87	5/8*	-	16,000	17,760	22,815
16.00*	-	-	16,000	17,760	22,815
17.00	-	-	16,937	18,802	
17.46	11/16	-	16,937	18,802	
18.00	-	-	18,331	20,350	
19.00	-	-	19,381	21,514	
19.05	3/4	-	19,381	21,514	
20.00	-	-	23,157	25,705	

DRILL SET (IS : 5101 - 1991)

DRILL SET	PRICE Rs. / SET	
	STD. JOBBER DRILLS	GOLD JOBBER DRILLS
1.50 TO 6.50 MM (13 Pcs.)	1,502	1,669
1.00 TO 10.00 MM (19 Pcs.)	4,185	4,647
1.00 TO 13.00 MM (25 Pcs.)	8,861	9,835
1/16 TO 1/4 INCH (13 Pcs.)	1,502	1,669
1/16 TO 3/8 INCH (21 Pcs.)	4,465	4,963
1/16 TO 1/2 INCH (29 Pcs.)	9,848	11,528

HSS PARALLEL SHANK STUB SERIES (IS : 5100 - 1969)

SIZES		PRICE Rs. / 10 Nos.		
MM	INCH	STD. STUB DRILLS	GOLD STUB DRILLS	SUPER STUB DRILLS
1.50		398	441	-
1.60		398	441	-
1.90		398	441	-
2.00		398	441	-
2.20		398	441	-
2.50		398	441	-
2.78	7/64	398	441	-
2.90		433	482	-
3.00	-	446	497	638
3.17	1/8*	528	587	753
3.20	-	557	617	793
3.50	-	557	617	793
3.57	9/64	557	617	793
3.97	5/32*	791	877	1,128
4.00	-	791	877	1,128
4.20	-	889	987	1,268
4.50	-	1,176	1,308	1,679
4.76	3/16	1,176	1,308	1,679
5.00	-	1,260	1,397	1,795
5.16	13/64	1,260	1,397	1,795
5.50	-	1,365	1,515	1,944
5.56	7/32	1,365	1,515	1,944
6.00	-	1,545	1,712	2,200

SIZES		PRICE Rs. / 10 Nos.		
MM	INCH	STD. STUB DRILLS	GOLD STUB DRILLS	SUPER STUB DRILLS
6.35	1/4	1,725	1,915	2,460
6.50	-	2,116	2,348	3,016
6.75	17/64	2,116	2,348	3,016
6.80	-	2,116	2,348	3,016
7.00	-	2,325	2,579	3,314
7.14	9/32*	2,325	2,579	3,314
7.50	-	2,409	2,674	3,436
7.94	5/16*	2,918	3,240	4,162
8.00	-	2,918	3,240	4,162
8.50	-	3,653	4,055	5,210
9.00	-	3,815	4,235	5,441
9.50	-	4,025	4,468	5,738
9.52	3/8	4,204	4,666	5,994
10.00	-	5,145	5,713	7,338
10.50	-	5,535	6,145	-
11.00	-	6,232	6,918	8,886
11.11	7/16	6,918	7,207	9,258
12.00	-	7,354	8,164	10,487
12.70	1/2	8,144	9,039	11,613
13.00	-	8,144	9,039	11,613
14.00	-	11,100	12,319	-
15.00	-	12,499	13,874	-
16.00	-	13,550	15,043	-

• Standard, Gold - Stub & Jobber Series = M2

• Super Stub & Jobber = M35

HSS DRILLS

HSS PARALLEL SHANK LONG SERIES (IS : 5102 - 1969)

SIZES		PRICE Rs. / PIECE	SIZES		PRICE Rs. / PIECE	SIZES		PRICE Rs. / PIECE
MM	INCH		MM	INCH		MM	INCH	
1.00	-	239	3.57	9/64	311	7.00	-	869
1.10	-	239	3.70	-	337	7.20	-	869
1.19	-	239	3.80	-	337	7.50	-	869
1.20	-	239	3.97	5/32	337	7.80	-	869
1.30	-	239	4.00	-	337	7.94	5/16	895
1.40	-	239	4.10	-	337	8.00	-	895
1.50	-	239	4.20	-	337	8.10	-	895
1.59	1/16	239	4.30	-	337	8.20	-	895
1.60	-	239	4.50	-	337	8.50	-	895
1.70	-	239	4.76	3/16	337	9.00	-	990
1.80	-	239	4.80	-	337	9.50	-	990
1.90	-	239	4.90	-	390	9.52	3/8	990
1.98	5/64	239	5.00	-	390	9.80	-	1,154
2.00	-	239	5.10	-	390	10.00	-	1,246
2.10	-	239	5.16	13/64	390	10.20	-	1,305
2.20	-	239	5.20	-	390	10.50	-	1,343
2.30	-	306	5.30	-	457	11.00	-	1,522
2.38	3/32	306	5.50	-	457	11.50	-	1,387
2.40	-	306	5.56	7/32	457	11.80	-	1,387
2.50	-	306	5.60	-	495	12.00	-	1,387
2.60	-	306	5.80	-	495	12.50	-	1,923
2.70	-	306	5.90	-	495	12.70	1/2	2,137
2.78	7/64	306	5.95	15/64	495	13.00	-	2,137
2.80	-	306	6.00	-	495	13.50	-	2,137
2.90	-	306	6.10	-	560	14.00	-	2,137
3.00	-	311	6.35	1/4	513	14.29	9/16	2,137
3.10	-	311	6.50	-	719	14.50	-	2,236
3.17	1/8	311	6.60	-	869	15.00	-	2,236
3.20	-	311	6.75	17/64	869	15.50	-	2,325
3.30	-	311	6.80	-	869	15.87	5/8	2,325
3.50	-	311	6.90	-	869	16.00	-	2,355

Note : Minimum order value required is Rs.10000/- nett.

HSS PARALLEL SHANK - EXTRA LONG SERIES

SIZES		OAL MM FL MM	PRICE Rs. / PIECE						
MM	INCH		150	175	200	225	250	300	350
3.00	1/8	-	904	1,088	1,245	1,467	1,759	2,109	-
3.50	-	-	940	1,095	1,252	1,699	1,885	2,488	-
4.00	5/32	-	903	1,095	1,252	1,701	1,891	2,488	3,425
4.50	-	-	909	1,121	1,281	1,704	1,895	2,667	3,512
5.00	3/16	-	932	1,147	1,305	1,736	1,935	2,728	3,580
5.50	7/32	-	985	1,207	1,387	1,863	2,064	2,734	3,601
6.00	-	-	985	1,237	1,410	1,909	2,123	2,806	4,176
6.50	1/4	-	-	-	1,707	-	2,465	3,179	4,176
7.00	-	-	-	-	1,792	-	2,682	3,217	4,672
7.50	9/32	-	-	-	1,891	-	2,834	3,404	4,690
8.00	5/16	-	-	-	1,999	-	3,003	3,460	4,797
8.50	11/32	-	-	-	2,069	-	3,056	3,563	4,365
9.00	-	-	-	-	2,075	-	3,056	3,563	4,365
9.50	3/8	-	-	-	2,135	-	3,063	3,673	4,499
10.00	-	-	-	-	2,169	-	3,129	4,151	5,099
10.50	13/32	-	-	-	2,355	-	3,250	4,365	5,534
11.00	7/16	-	-	-	-	-	3,278	4,462	5,770
11.50	-	-	-	-	-	-	3,436	4,546	5,997
12.00	15/32	-	-	-	-	-	3,445	4,560	6,148
12.50	1/2	-	-	-	-	-	3,650	4,834	6,517

Note : Other details will be maintained as per IS : 7823 - 2005.

- MOQ up to 6 mm - 30 Nos.
- MOQ above to 6 mm - 15 Nos.



MIRANDA TOOLS
Premium quality cutting tools

DORMER PRAMET

New Launch

HSS PARALLEL SHANK
TWIST JOBBER DRILLS,
(FORGED FORM)

MIRANDA
i-Drill



HSS DRILLS

**HSS PARALLEL SHANK JOBBER SERIES (IS : 5101 - 1991)
(FORGED FORM)**

SIZE		FL	OAL	Price Rs. / 10 Nos.
MM	INCH			
2.00-2.10	-	24	49	442
2.20-2.30	-	27	53	442
2.40-2.60	-	30	57	442
2.70-2.78	7/64	33	61	442
3.10-3.20	1/8	36	65	578
3.30	-	36	65	602
3.40-3.50	9/64	39	70	602
3.60-3.70	-	39	70	847
3.80-4.00	-	43	75	847
4.10-4.20	-	43	75	1,031
4.30-4.40	-	47	80	1,344
4.50-4.70	-	47	80	1,351
4.80	3/16	52	86	1,351
4.90-5.00	-	52	86	1,461
5.00-5.30	-	52	86	1,782
5.40-5.60	-	57	93	1,782
5.70-6.00	-	57	93	1,782
6.10-6.40	1/4	63	101	1,940
6.50-6.70	-	63	101	2,469
6.80	17/64	69	109	2,469
6.9-7.00	-	69	109	2,702
7.10-7.50	-	69	109	3,389
7.60-8.00	5/16	75	117	3,389
8.10-8.20	-	75	117	4,114
8.30-8.50	-	75	117	4,114
8.60-8.70	-	81	125	5,723
8.80-9.00	-	81	125	5,723
9.10-9.50	-	81	125	5,723
9.60-9.80	3/8	87	133	5,723
9.90-10.00	-	87	133	5,723

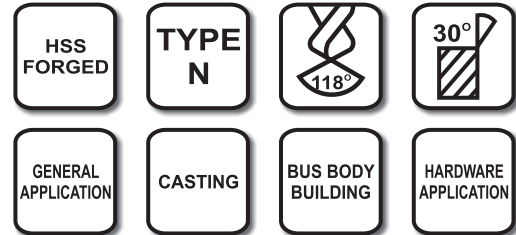

FEATURES

- Optimise Geometry for Casting Application
- Faster Chips Evacuation
- Longer Drill Point Life

APPLICATIONS

- Steel
- Cast Iron
- Brass
- Aluminium
- Non - ferrous metal

Size Range	Packing Type	Qty.
2.0 mm - 5.30 mm	Pouch & Carton	100nos (10 x 10)
5.50 mm - 10 mm	Blister	10 nos

HSS DRILLS HSS CENTRE DRILLS



TYPE 'A' & 'R' IS : 6708/6710 - 1977			TYPE 'B' IS : 6709 - 1977			B.S. 328 (PART 2) 1950			
PILOT DIA MM	BODY DIA MM	PRICE RS./PIECE	PILOT DIA MM	BODY DIA MM	PRICE RS./PIECE	SIZE B.S. NO.	PILOT DIA INCH	BODY DIA INCH	PRICE RS./PIECE
1.00	3.15	213	1.00	4.00	350	BS-1	3/64"	1/8"	213
1.25	3.15	213	1.25	5.00	377	BS-2	1/16"	3/16"	213
1.60	4.00	213	1.60	6.30	441	BS-3	3/32"	1/4"	245
2.00	5.00	213	2.00	8.00	620	BS-4	1/8"	5/16"	381
2.50	6.30	245	2.50	10.00	790	BS-5	3/16"	7/16"	503
3.15	8.00	381	3.15	11.20	1,057	BS-6	1/4"	5/8"	945
4.00	10.00	471	4.00	14.00	1,416	BS-7	5/16"	3/4"	1,461
5.00	12.50	801	5.00	18.00	2,021	-	-	-	-
6.30	16.00	945	6.30	20.00	2,380	-	-	-	-
8.00	20.00	1,461	-	-	-	-	-	-	-

HSS TAPER SHANK DRILLS IS : 5103 - 1969

SIZES		PRICE RS. / PIECE		SIZES		PRICE RS. / PIECE		SIZES		PRICE RS. / PIECE	
MM	INCH	REGULAR	SUPER	MM	INCH	REGULAR	SUPER	MM	INCH	REGULAR	SUPER
3.00	-	376	550	10.20	-	986	1,444	17.25	-	2,490	3,648
3.20	-	395	578	10.50	-	1,168	1,712	17.46	11/16*	2,490	3,648
3.50	-	376	550	10.80	-	1,221	1,789	17.50	-	2,582	3,784
3.80	-	395	578	11.00	-	1,221	1,789	17.75	-	2,612	3,828
4.00	-	376	550	11.11	7/16*	1,221	1,789	18.00	-	2,731	4,003
4.20	-	507	742	11.20	-	1,255	1,839	18.25	-	2,731	4,003
4.50	-	507	742	11.50	-	1,255	1,839	18.26	23/32	2,731	4,003
4.76	3/16	507	742	11.80	-	1,255	1,839	18.50	-	2,731	4,003
4.80	-	522	765	12.00	-	1,275	1,867	18.75	-	2,756	4,038
5.00	-	507	742	12.20	-	1,275	1,867	19.00	-	2,756	4,038
5.20	-	522	765	12.50	-	1,275	1,867	19.05	3/4*	2,756	4,038
5.50	-	507	742	12.70	1/2*	1,275	2,586	19.25	-	2,895	4,242
5.80	-	522	765	12.80	-	1,765	2,586	19.50	-	2,895	4,242
6.00	-	507	742	13.00	-	1,765	2,586	19.75	-	2,895	4,242
6.20	-	576	841	13.20	-	1,848	2,708	19.84	25/32	2,895	4,242
6.35	1/4*	566	830	13.49	17/32*	1,848	2,708	20.00	-	3,111	4,559
6.50	-	578	845	13.50	-	1,979	2,899	20.25	51/64	3,143	4,606
6.75	17/64*	586	857	13.80	-	1,979	2,899	20.50	-	3,143	4,606
6.80	-	586	857	14.00	-	1,979	2,899	20.64	13/16*	3,143	4,606
7.00	-	578	845	14.25	-	2,118	3,105	20.75	-	3,286	4,816
7.20	-	586	857	14.29	9/16*	2,118	3,105	21.00	-	3,286	4,816
7.50	-	578	845	14.50	-	2,212	3,241	21.25	-	3,374	4,943
7.80	-	586	857	14.75	-	2,212	3,241	21.43	27/32	3,374	4,943
7.94	5/16*	578	845	15.00	-	2,212	3,241	21.50	-	3,465	5,076
8.00	-	578	845	15.25	-	2,247	3,291	21.75	-	3,465	5,076
8.20	-	829	1,214	15.50	-	2,247	3,291	22.00	-	3,532	5,176
8.50	-	753	1,102	15.75	-	2,247	3,291	22.22	7/8	3,532	5,176
8.80	-	911	1,333	15.87	5/8*	2,247	3,291	22.25	-	3,850	5,642
9.00	-	829	1,214	16.00	-	2,298	3,367	22.50	-	3,850	5,642
9.20	-	911	1,333	16.25	-	2,298	3,367	22.75	-	3,924	5,749
9.50	-	829	1,214	16.50	-	2,456	3,599	23.00	29/32	3,924	5,749
9.52	3/8*	829	1,214	16.67	21/32	2,456	3,599	23.25	-	4,116	6,032
9.80	-	976	1,430	16.75	-	2,456	3,599	23.50	-	4,684	6,863
10.00	-	881	1,342	17.00	-	2,456	3,599	23.75	-	4,684	6,863

Note : • Minimum order value required is Rs.10000 /-

• MOQ in Super Series : From 3mm to 10mm - 50 Nos.,
From 10mm to 20mm - 30 Nos.

From 20mm to 32mm - 10 Nos.
From 32mm to 50mm - 5 Nos.

Above 50mm - 2 Nos.

SIZES		PRICE RS. / PIECE	
MM	INCH	REGULAR	SUPER
24.00*	-	4,807	7,043
24.25	-	4,894	7,172
24.50*	-	4,894	7,172
24.75	-	5,123	7,507
25.00*	63/64	5,123	7,507
25.40	1*	5,192	7,608
25.50*	-	5,638	8,260
25.75	-	5,638	8,260
26.00*	-	5,688	8,334
26.25	-	6,115	8,960
26.50*	-	6,253	9,164
27.00*	-	6,453	9,456
27.25	-	6,467	9,477
27.50	-	6,467	9,477
27.75	-	6,467	9,477
28.00*	-	7,105	10,411
28.25	-	7,105	10,411
28.50	-	7,105	10,411
28.58	1.1/8	7,105	10,411
28.75	-	7,314	10,717
29.00*	-	7,421	10,875
29.25	-	7,421	10,875
29.50	-	7,459	10,931
29.75	-	7,459	10,931
30.00*	-	7,615	11,160
30.25	-	8,657	12,686
30.50*	-	8,657	12,686
30.75	-	8,797	12,890
31.00*	-	9,788	14,344
31.50	-	10,229	14,990
31.75	1.1/4	10,229	14,990
32.00*	-	11,199	16,412
32.50	-	11,199	16,412
33.00*	-	11,479	16,822
33.34	1.5/16	11,479	16,822
33.50	-	11,874	17,400
34.00*	-	12,104	17,738
34.50	-	13,251	19,418
34.93	1.3/8	13,358	19,575
35.00*	-	13,358	19,575
35.50	-	14,171	20,765
36.00*	-	14,381	21,074

SIZES		PRICE RS. / PIECE	
MM	INCH	REGULAR	SUPER
36.50	1.7/16	14,661	21,485
37.00*	-	15,013	22,000
37.50	-	16,006	23,455
38.00*	-	16,254	23,819
38.10	1.1/2	16,254	23,819
38.50	1.33/64	16,745	24,538
39.00*	-	17,738	25,994
39.50	-	17,738	25,994
39.69	1.9/16	17,738	25,994
40.00*	-	18,199	26,668
40.50	-	19,252	28,212
41.00	-	19,252	28,212
41.27	1.5/8	19,252	28,212
41.50	-	20,006	29,318
42.00*	-	20,006	29,318
42.50	-	20,516	30,063
43.00	-	21,258	31,151
43.50	-	21,258	31,151
44.00	-	22,007	32,251
44.45	1.3/4	22,007	32,251
44.50	-	22,007	32,251
45.00*	-	22,523	33,004
45.50	-	23,544	34,501
46.00	-	23,544	34,501
46.50	-	24,726	36,234
47.00	-	24,726	36,234
47.50	-	25,246	36,995
47.62	1.7/8	25,246	36,995
48.00	-	27,530	40,344
48.50	-	27,736	40,645
49.00	-	27,736	40,645
49.50	-	28,028	41,074
50.00	-	28,028	41,074
50.50	-	29,524	43,264
50.80	2	29,524	43,264
51.00	-	40,079	58,732
52.00	-	40,079	58,732
52.50	-	52,163	76,441
53.00	-	52,163	76,441
53.50	-	52,163	76,441
53.97	2.1/8	52,163	76,441
54.00	-	52,163	76,441

SIZES		PRICE RS. / PIECE	
MM	INCH	REGULAR	SUPER
54.50	-	54,796	80,299
55.00	-	54,796	80,299
55.50	-	54,796	80,299
55.56	2.3/16	54,796	80,299
56.00	-	57,097	83,670
56.50	-	57,097	83,670
57.00	-	57,097	83,670
57.15	2.1/4	57,097	83,670
57.50	-	62,315	91,319
58.00	-	62,315	91,319
58.50	-	62,315	91,319
58.74	2.5/16	62,315	91,319
59.00	-	63,504	93,059
59.50	-	63,504	93,059
60.00	-	63,504	93,059
60.32	2.3/8	63,504	93,059
60.50	-	67,502	98,918
61.00	-	67,502	98,918
61.50	-	67,502	98,918
62.00	-	67,502	98,918
62.50	-	67,502	98,918
63.00	-	68,638	100,582
63.50	2.1/2	68,638	100,582
64.00	-	75,856	111,161
65.00	-	75,856	111,161
65.09	2.9/16	75,856	111,161
66.00	-	76,425	111,994
66.67	2.5/8	76,425	111,994
67.00	-	78,287	114,723
68.00	-	83,900	122,948
69.00	-	90,949	133,278
69.85	2.3/4	90,949	133,278
70.00	-	90,949	133,278
71.00	-	98,122	143,789
71.50	-	98,122	143,789
72.00	-	100,051	146,618
73.00	-	100,051	146,618
73.02	2.7/8	100,051	146,618
74.00	-	106,469	156,022
75.00	-	107,848	158,043
76.00	-	107,848	158,043
76.20	3	107,848	158,043

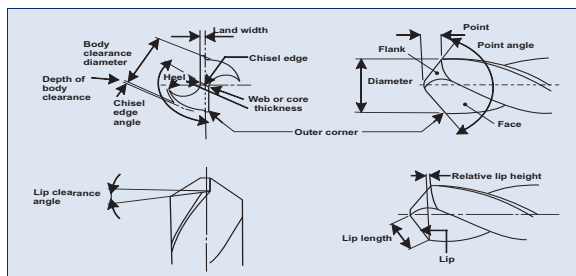

Note : • Minimum order value required is Rs.10000 /- • Tax extra as applicable on date of supply. • Prices are subjected to changes without notice.
 • MOQ in Super Series : From 3mm to 10mm - 50 Nos., From 20mm to 32mm - 10 Nos. Above 50mm - 2 Nos.
 From 10mm to 20mm - 30 Nos. From 32mm to 50mm - 5 Nos.

HSS DRILLS

HSS TAPER SHANK TWIST DRILLS (LONG SERIES)

IS : 8305 - 1976 (Type N)



SIZES		OAL	PRICE Rs. / PIECE
MM	INCH	MM	
5.00	-	155	1,239
5.16	13/64	155	1,239
5.56	7/32	161	1,383
6.00	-	161	1,383
6.35	1/4	167	1,547
6.50	-	167	1,547
7.00	-	174	1,662
7.50	-	174	1,717
7.94	5/16	181	1,815
8.00	-	181	1,815
8.50	-	181	1,853
9.00	-	188	2,006
9.50	-	188	2,053
9.52	3/8	197	2,053
10.00	-	197	2,334
10.50	-	197	2,401
11.00	-	206	2,452
11.11	7/16	206	2,542
11.50	-	206	2,542
12.00	-	215	3,018
12.50	-	215	3,182
12.70	1/2	215	3,182
13.00	-	215	3,182
13.49	17/32	223	3,483
13.50	-	223	3,483
14.00	-	223	3,624
14.29	9/16	245	4,524
14.50	-	245	4,524
15.00	-	245	4,533
15.50	-	251	4,733
15.87	5/8	251	4,855
16.00	-	251	4,855
16.50	-	257	4,940
17.00	-	257	5,043
17.50	-	263	5,477
18.00	-	263	5,488
18.50	-	269	5,577
19.00	-	269	5,666
19.05	3/4	275	5,666

SIZES		OAL	PRICE Rs. / PIECE
MM	INCH	MM	
19.50	-	275	5,821
20.00	-	275	5,919
20.50	-	282	6,017
21.00	-	282	6,129
21.43	27/32	289	7,119
21.50	-	289	7,119
21.75	-	289	7,264
22.00	-	289	7,264
22.22	7/8	289	7,757
22.50	-	296	7,757
23.00	-	296	8,129
23.50	-	319	9,933
24.00	-	327	9,933
24.50	-	327	10,368
25.00	-	327	10,743
25.40	1	335	10,743
25.50	-	335	10,743
26.00	-	335	11,173
26.50	-	335	11,497
27.00	-	343	13,628
27.50	-	343	14,061
28.00	-	343	14,497
28.50	-	351	14,961
29.00	-	351	15,383
29.50	-	351	15,811
30.00	-	351	16,259
30.50	-	360	16,688
31.00	-	360	16,688
31.50	-	360	16,809
32.00	-	397	20,111
32.50	-	397	20,977
33.00	-	397	20,977
34.00	-	406	21,891
34.50	-	406	22,851
35.00	-	406	22,851
36.00	-	416	25,042
38.00	-	426	28,134
38.10	1.1/2	426	29,055
40.00	-	426	30,207

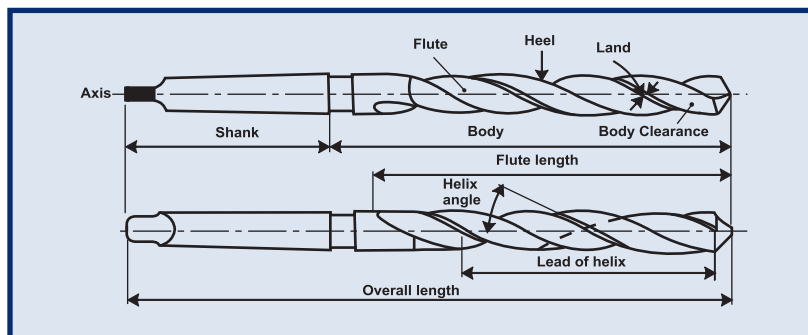

HSS TAPER SHANK TWIST DRILLS (EXTRA LONG SERIES)

IS : 7822 - 2005

SIZES		OVERALL LENGTH IN MM									
		200	225	250	275	300	315	325	350	375	400
MM	INCH	PRICE RS./PIECE									
10.00	-	2,332	2,641	2,980	3,480	4,008	4,376	-	-	-	-
10.50	-	2,401	2,741	3,182	3,678	4,215	4,563	4,795	5,485	-	-
11.00	-	2,452	2,827	3,210	3,735	4,293	4,714	4,921	5,583	-	-
11.50	7/16	2,542	2,885	3,295	3,832	4,397	4,795	5,011	5,735	-	-
12.00	-	-	3,018	3,436	3,981	4,561	4,983	5,235	5,919	-	-
12.50	1/2	-	3,182	3,553	4,126	4,703	5,140	5,376	6,199	-	-

SIZES		OVERALL LENGTH IN MM									
		250	275	300	315	325	350	375	400	450	500
MM	INCH	PRICE RS./PIECE									
13.00	-	4,215	4,829	5,746	6,235	6,263	7,126	-	-	-	-
13.50	-	4,350	4,927	5,901	6,389	6,373	7,260	-	-	-	-
14.00	-	4,496	5,074	6,009	6,519	6,477	7,404	8,365	9,388	-	-
14.50	9/16	4,524	5,141	6,094	6,553	6,570	7,543	8,508	9,557	12,540	15,823
15.00	-	4,626	5,257	6,245	6,692	6,729	7,696	8,631	9,708	12,689	15,985
15.50	-	4,733	5,375	6,303	6,825	6,821	7,815	8,796	9,838	12,812	16,124
16.00	5/8	4,855	5,466	6,428	6,921	6,947	7,928	8,930	10,042	13,032	16,301
16.50	-	4,938	5,540	6,553	7,050	7,055	8,066	9,096	10,253	13,172	16,401
17.00	-	5,042	5,672	6,620	7,136	7,150	8,195	9,220	10,368	13,332	16,554
17.50	11/16	-	-	6,785	7,274	7,289	8,354	9,374	10,489	13,487	16,710
18.00	-	-	-	6,883	7,435	7,405	8,487	9,538	10,683	13,628	16,872
18.50	-	-	-	6,992	7,526	7,539	8,561	9,651	10,849	13,783	17,034

SIZES		OVERALL LENGTH IN MM									
		300	315	325	350	375	400	425	450	475	500
MM	INCH	PRICE RS./PIECE									
19.00	3/4	6,793	7,289	7,649	8,706	9,799	10,992	12,382	13,943	15,439	16,987
19.50	-	6,878	7,370	7,726	8,865	9,994	11,216	12,540	14,044	15,624	17,297
20.00	-	6,996	7,493	7,873	8,966	10,128	11,377	12,784	14,318	15,797	17,492
20.50	-	7,127	7,630	7,983	9,115	10,253	11,549	12,940	14,495	16,039	17,761
21.00	13/16	7,254	7,777	8,118	9,991	10,467	11,740	13,219	14,732	16,335	18,043
21.50	-	7,405	7,906	8,254	9,473	10,666	11,963	13,414	15,024	16,629	18,404
22.00	-	7,564	8,116	8,488	9,652	10,852	12,164	13,628	15,262	16,893	18,699
22.50	7/8	7,757	8,286	8,672	9,813	10,992	12,293	13,860	15,488	17,187	19,015
23.00	-	8,129	8,674	8,995	10,139	11,235	12,513	14,061	15,783	17,440	19,297
23.50	-	8,930	-	9,932	10,886	11,967	12,939	14,538	16,229	17,964	19,895
24.00	15/16	8,930	-	9,932	10,993	12,120	13,392	14,998	16,743	18,452	20,424
24.50	-	9,209	-	10,368	11,496	12,540	13,852	15,488	17,220	18,995	20,977
25.00	-	-	-	10,745	11,915	13,032	14,276	15,927	17,718	19,521	21,562
25.50	1	-	-	-	12,287	13,414	14,700	16,385	18,185	20,046	22,070
26.00	-	-	-	-	12,785	13,903	15,180	16,872	18,720	20,567	22,654
26.50	-	-	-	-	13,172	14,306	15,601	17,339	19,201	21,051	23,209
27.00	1.1/16	-	-	-	13,628	14,810	16,064	17,800	19,682	21,600	23,754
27.50	-	-	-	-	14,061	15,185	16,462	18,271	20,175	22,101	24,288
28.00	-	-	-	-	14,497	15,624	16,945	18,720	20,664	23,098	24,876
28.50	1.1/8	-	-	-	14,961	16,084	17,366	19,154	21,169	23,175	25,387

SIZES		OVERALL LENGTH IN MM									
		300	315	325	350	375	400	425	450	475	500
MM	INCH	PRICE RS./PIECE									
29.00	-	-	-	-	15,383	16,528	17,836	19,643	21,673	23,663	25,962
29.50	-	-	-	-	15,805	16,945	18,259	20,110	22,133	24,195	26,533
30.00	1.3/16	-	-	-	16,257	17,399	18,710	20,567	22,632	24,707	27,054
31.00	1.1/4	-	-	-	16,688	17,834	19,165	21,075	23,220	25,352	27,817
32.00	-	-	-	-	16,810	18,185	20,110	22,101	24,342	26,533	29,109
33.00	1.5/16	-	-	-	-	-	20,977	23,084	25,428	27,716	30,379
34.00	-	-	-	-	-	-	21,894	24,063	26,519	28,918	31,685
35.00	1.3/8	-	-	-	-	-	22,851	25,121	27,611	30,129	32,979
36.00	-	-	-	-	-	-	23,754	26,074	28,676	31,290	34,269
37.00	1.7/16	-	-	-	-	-	24,655	27,054	29,765	32,464	35,517
38.00	1.1/2	-	-	-	-	-	25,596	28,133	30,921	33,680	36,867
39.00	-	-	-	-	-	-	26,534	29,363	31,907	34,752	37,967
40.00	-	-	-	-	-	-	27,640	30,206	33,028	35,926	39,215
41.00	1.5/8	-	-	-	-	-	-	-	-	-	40,513
42.00	-	-	-	-	-	-	-	-	-	-	42,316
43.00	-	-	-	-	-	-	-	-	-	-	44,189
44.00	-	-	-	-	-	-	-	-	-	-	46,036
45.00	1.3/4	-	-	-	-	-	-	-	-	-	47,911
46.00	1.13/16	-	-	-	-	-	-	-	-	-	49,937
47.00	-	-	-	-	-	-	-	-	-	-	51,956
48.00	1.7/8	-	-	-	-	-	-	-	-	-	53,983
49.00	1.15/16	-	-	-	-	-	-	-	-	-	55,969
50.00	-	-	-	-	-	-	-	-	-	-	58,225

MASONRY DRILLS - CARBIDE TIPPED (GROUND FLUTED & BRIGHT PLATED)

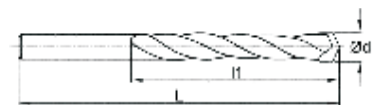

SIZES		FLUTE LENGTH	OVERALL LENGTH	PRICE RS. / PIECE
MM	INCH			STD DRILLS
3	1/8"	40	76	48
4	5/32"	45	85	55
5	3/16"	45	90	61
5.5	7/32"	45	90	74
6	15/64"	60	110	79
6.5	1/4"	60	110	79
7	9/32"	60	110	148
8	5/16"	80	120	129
9	11/32"	80	120	150
10	3/8"	80	120	150
11	7/16"	115	160	209
12	15/32"	115	160	186
13	1/2"	115	160	186

HSS ENDMILLS

HSS PARALLEL SHANK ENDMILLS IS 6353 - 1991 & BS-122 (PART-1) 1953

Dia		Price Each Rs.		Dia		Price Each Rs.		Dia		Price Each Rs.		Dia		Price Each Rs.	
MM	INCH	M2	M42	MM	INCH	M2	M42	MM	INCH	M2	M42	MM	INCH	M2	M42
3*	1/8	606	969	15*	-	1,141	1,828	27	-	2,494	3,987	40	-	5,951	9,520
4*	5/32	606	969	16*	5/8	1,148	1,837	28	1.1/8	2,911	4,655	41	1.5/8	5,951	9,520
5*	3/16	606	969	17	-	1,256	2,012	29	-	2,911	4,655	42	-	6,769	10,831
6*	1/4*	679	1,084	18*	-	1,393	2,230	30*	-	3,201	5,124	43	-	6,769	10,831
7	-	766	1,226	19*	3/4	1,393	2,230	32	1.1/4	3,491	5,587	45	1.3/4	7,584	12,131
8*	5/16	766	1,226	20*	13/16	1,543	2,467	33	-	3,866	6,186	46	-	7,584	12,131
9*	3/8*	766	1,226	21	-	1,736	2,781	34	1.3/8	4,216	6,745	47	1.7/8	8,363	13,380
10*	-	766	1,226	22*	7/8	1,750	2,799	35	-	4,216	6,745	48	-	8,363	13,380
11	7/16	766	1,226	23	-	1,901	3,040	36	-	4,596	7,355	49	-	8,363	13,380
12*	1/2*	792	1,267	24*	-	1,901	3,040	37	-	4,952	7,920	50	-	9,175	14,677
13	-	902	1,439	25*	1.0	2,040	3,261	38	-	5,280	8,446	-	-	-	-
14*	9/16	981	1,574	26	-	2,120	3,390	39	-	5,598	8,956	-	-	-	-

HSS PARALLEL SHANK SLOT DRILLS IS 6352 - 1991 & BS (PART - 1) 1953

Dia		Price Each Rs.		Dia		Price Each Rs.		Dia		Price Each Rs.		Dia		Price Each Rs.	
MM	INCH	M2	M42	MM	INCH	M2	M42	MM	INCH	M2	M42	MM	INCH	M2	M42
3	1/8	738	1,182	14	9/16	1,148	1,837	26	-	3,112	4,980	43	-	7,160	11,456
4	5/32	738	1,182	15	-	1,294	2,072	30	-	3,821	6,113	44	-	7,160	11,456
5*	3/16	738	1,182	16	5/8	1,292	2,068	32	1.1/4	3,821	6,113	45	1.3/4	7,160	11,456
6*	1/4	792	1,269	18	-	1,589	2,540	34	1.3/8	4,596	7,355	46	-	7,949	12,718
7	-	792	1,269	20*	3/4	1,589	2,540	35	-	4,596	7,355	47	1.7/8	7,949	12,718
8*	5/16	792	1,269	21	13/16	1,855	2,967	36	-	4,934	7,895	48	-	7,949	12,718
9	3/8	792	1,269	22	7/8	1,855	2,967	38	1.1/2	5,323	8,515	49	-	8,718	13,950
10*	-	819	1,308	23	-	2,204	3,527	40	-	5,691	9,106	50	2.0	8,718	13,950
11	-	819	1,308	24	-	2,204	3,527	41	-	6,441	10,305	-	-	-	-
12	1/2	897	1,436	25	1.0	2,204	3,527	42	-	6,441	10,305	-	-	-	-

HSS PARALLEL SHANK ENDMILLS - : LONG SERIES IS 6353 - 1991

Dia		Price Each Rs.		Dia		Price Each Rs.		Dia		Price Each Rs.		Dia		Price Each Rs.	
MM	M2	M42	MM	M2	M42	MM	M2	M42	MM	M2	M42	MM	M2	M42	
3	787	1,260	9	997	1,593	20	2,006	3,210	32	4,538	7,261	44	7,736	12,374	
4	787	1,260	10*	997	1,593	22	2,276	3,640	33	5,027	8,042	45	9,856	15,772	
5	787	1,260	12*	1,029	1,646	25	2,652	4,243	36	5,976	9,562	50	11,927	19,082	
6	883	1,412	14	1,279	2,044	26	2,755	4,408	40	7,736	12,374				
7	997	1,593	16	1,492	2,386	28	3,784	6,054	45	9,856	15,772				
8	997	1,593	18	1,811	2,897	30	4,163	6,662	50	11,927	19,082				

HSS PARALLEL SHANK ROUGHING END MILLS -M42 4 FLUTES - COARSE PITCH - TO IS : 6353 -1991 / BS:122

SIZE		PRICE RS. / PIECE	
MM	INCH	STANDARD SERIES	LONG SERIES
6	1/4	2,191	2,978
8	5/16	2,191	2,978
10	3/8	2,191	2,978
12	1/2	2,191	2,978
14	-	3,330	4,530
16	5/8	3,875	5,279
18	-	4,723	5,891
20	3/4	5,272	7,178
22	7/8	5,655	7,703
25	1	6,667	9,089
28	1.1/8	8,991	12,249
30	-	10,795	14,712

HSS REAMERS



REFERENCE STANDARDS

HSS HAND REAMERS WITH PARALLEL SHANK
HSS MACHINE REAMERS WITH TAPER SHANK
HSS CHUCKING REAMERS WITH PARALLEL SHANK
HSS CHUCKING REAMERS WITH TAPER SHANK

MM SIZE INCH SIZES
IS : 5444 - 1978 BS 328 PART-4
IS : 5445 - 1978 1983
IS : 5446 - 1978
IS : 5447 - 1978

SIZE		PRICE Rs. /PIECE
DIAMETER		HAND REAMER LONG FLUTED MACHINE REAMER CHUCKING REAMER
MM	INCH	
4.00	-	1,047
(4.76)	3/16	1,047
4.50	-	1,047
5.00	-	1,047
(5.56)	7/32	1,047
6.00	-	1,220
(6.35)	1/4	1,220
7.00	-	1,220
(7.14)	9/32	1,220
(7.94)	5/16	1,389
8.00	-	1,389
(8.73)	11/32	1,459
9.00	-	1,459
(9.52)	3/8	1,586
10.00	-	1,758
(10.32)	13/32	1,758
11.00	-	1,969
(11.11)	7/16	1,969
(11.91)	15/32	2,053
12.00	-	2,053
(12.70)	1/2	2,122
13.00	-	2,588
(13.49)	17/32	2,588
14.00	-	2,588
(14.29)	9/16	2,588
15.00	-	2,604
(15.08)	19/32	2,604
(15.87)	5/8	2,604
16.00	-	2,604
(16.67)	21/32	3,006
17.00	-	3,006
(17.46)	11/16	3,006
18.00	-	3,217
(18.26)	23/32	3,413
19.00	-	3,413
(19.05)	3/4	3,413
20.00	-	3,816
(20.64)	13/16	3,890
21.00	-	4,308
22.00	-	4,308
(22.22)	7/8	4,308
23.00	-	5,040
(23.81)	15/16	5,580

SIZE		PRICE Rs. /PIECE
DIAMETER		HAND REAMER LONG FLUTED MACHINE REAMER CHUCKING REAMER
MM	INCH	
24.00	-	5580
25.00	-	5596
(25.40)	1	5702
26.00	-	6910
(26.99)	1.1/16	7913
27.00	-	7913
28.00	-	7913
(28.57)	1.1/8	7913
29.00	-	8390
30.00	-	9051
(30.16)	1.3/16	9051
31.00	-	9993
(31.75)	1.1/4	9993
32.00	-	9993
33.00	-	11355
(33.34)	1.5/16	11355
34.00	-	12746
(34.92)	1.3/8	13944
35.00	-	13944
36.00	-	13944
(36.51)	1.7/16	14060
37.00	-	15315
38.00	-	15315
(38.10)	1.1/2	15315
39.00	-	16934
(39.69)	1.9/16	18489
40.00	-	18489
41.00	-	18668
(41.27)	1.5/8	18668
42.00	-	21986
(42.86)	1.11/16	21986
43.00	-	21986
44.00	-	21986
(44.45)	1.3/4	21986
45.00	-	25758
46.00	-	25758
47.00	-	27823
(47.62)	1.7/8	29882
48.00	-	29882
49.00	-	29882
(49.21)	1.15/16	29882
50.00	-	29882
(50.80)	2	29882

HSS TAPER PIN REAMERS (TAPER 1 IN 50)

HAND - IS : 5881 -1984

MACHINE - IS : 5918 - 1984

DIA	PRICE Rs. /PIECE	
MM	HAND	MACHINE
6	2,268	2,268
8	3,070	3,070
10	3,395	3,395
12	4,107	4,107
14	4,623	4,623

DIA	PRICE Rs. /PIECE	
MM	HAND	MACHINE
16	5,146	5,146
20	8,005	8,005
25	8,483	8,483
30	11,427	11,427
32	12,534	12,534

DIA	PRICE Rs. /PIECE	
MM	HAND	MACHINE
40	22,438	22,438
50	38,889	38,889
-	-	-
-	-	-
-	-	-

HSS TAPER PIN REAMERS (TAPER 1 IN 48)

HAND/MACHINE - BS 328 (PART 4) 1983

DIA	PRICE Rs. /PIECE	
MM	HAND	MACHINE
1/4	2,110	2,110
9/32	2,307	2,307
5/16	2,563	2,563
11/32	2,887	2,887

DIA	PRICE Rs. /PIECE	
MM	HAND	MACHINE
3/8	2,946	2,946
13/32	3,298	3,298
7/16	3,395	3,395
1/2	3,852	3,852

DIA	PRICE Rs. /PIECE	
MM	HAND	MACHINE
9/16	4,444	4,444
5/8	4,952	4,952
3/4	6,130	6,236
7/8	7,703	7,703

Reamer Terms - General Features

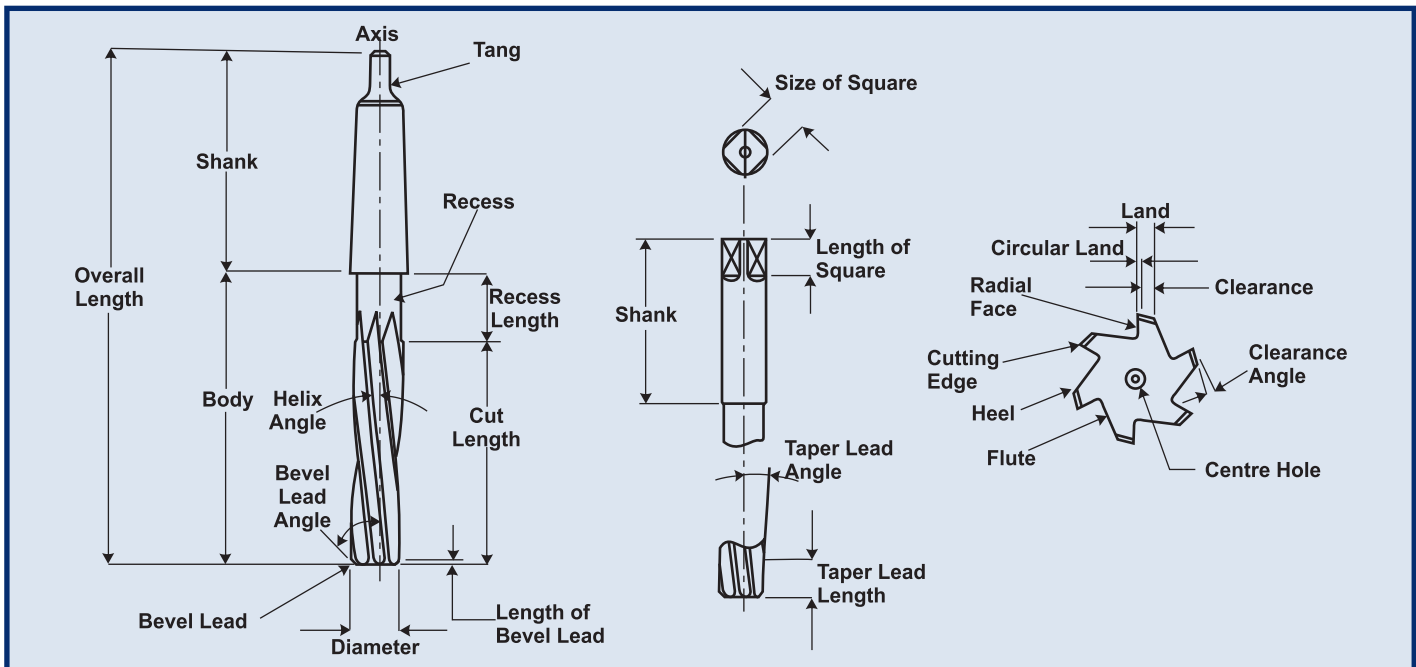

**HIGH SPEED STEEL
TAPER SHANK CORE DRILLS**



Specifications conform to : IS 5366 - 1978, ISO 7079 - 1981
DIN 343 - 1981, BS 328 - 1959
Dimensions in mm / Inch

Size		Price Rs. Piece
mm	inch	
14.00		2,168
14.29	9/16	2,230
15.00		2,327
15.08	19/32	2,327
15.87	5/8	2,350
16.00		2,350
16.67	21/32	2,507
17.00		2,507
17.46	11/16	2,708
18.00		2,912
18.26	23/32	2,912
19.00		3,329
19.05	3/4	3,329
19.84	25/32	3,341
20.00		3,341
20.64	13/16	3,575
21.00		3,575
21.43	27/32	3,778
22.00		3,778
22.22	7/8	4,008
23.00		4,244
23.02	29/32	4,244
23.81	15/16	4,632
24.00		4,840
24.61	31/32	4,840
25.00		5,625
25.40	1	5,625
26.00		6,069
26.19	1.1/32	6,069
26.99	1.1/16	6,700
27.00		6,700
27.78	1.3/32	6,954
28.00		7,367
28.57	1.1/8	7,369
29.00	1.5/32	7,704
29.37		7,704
30.00	1.3/16	8,192
30.16	1.7/32	8,192
30.96		8,502
31.00		9,560

Size		Price Rs. Piece
mm	inch	
31.75	1.1/4	9,978
32.00		10,934
32.54	1.9/32	10,934
33.00		11,161
33.34	1.5/16	11,161
34.00		12,171
34.13	1.11/32	12,171
34.92	1.3/8	12,932
35.00		12,932
35.72	1.13/32	13,909
36.00		13,909
36.51	1.7/16	14,673
37.00		14,673
37.31	1.15/32	15,089
38.00		16,142
38.10	1.1/2	16,142
39.00		17,703
39.69	1.9/16	17,703
40.00		17,703
41.00		19,511
41.27	1.5/8	19,511
42.00		20,090
42.07	1.21/32	20,090
42.86	1.11/16	20,734
43.00		20,734
44.00		21,917
44.45	1.3/4	21,917
45.00		22,691
45.24	1.25/32	22,691
46.00		23,532
46.04	1.13/16	23,532
47.00		24,453
47.62	1.7/8	25,714
48.00		25,714
49.00		27,458
49.21	1.15/16	27,458
50.00		29,547
50.80	2	32,670
51.00		32,954
52.00		36,292

Size		Price Rs. Piece
mm	inch	
52.39	2.1/16	36,292
53.00		42,394
53.97	2.1/8	42,394
54.00		42,394
55.00		44,436
55.56	2.3/16	44,436
56.00		46,318
57.00		46,318
57.15	2.1/4	46,318
58.00		50,615
58.74	2.5/16	50,615
59.00		51,551
60.00		51,551
60.32	2.3/8	51,551
61.00		54,939
61.91	2.7/16	54,939
62.00		54,939
63.00		60,464
63.50	2.1/2	60,464
64.00		66,021
65.00		66,021
65.09	2.9/16	66,021
66.00		69,221
66.67	2.5/8	69,221
67.00		72,111
68.00		75,613
68.26	2.11/16	75,613
69.00		79,306
69.85	2.3/4	80,793
70.00		80,793
71.00		82,394
71.44	2.13/16	82,394
72.00		86,159
73.00		89,354
73.02	2.7/8	89,354
74.00		92,732
74.61	2.15/16	92,732
75.00		96,150
76.00		100,767
76.20	3	100,767



Annular Cutters (HSS & TCT)

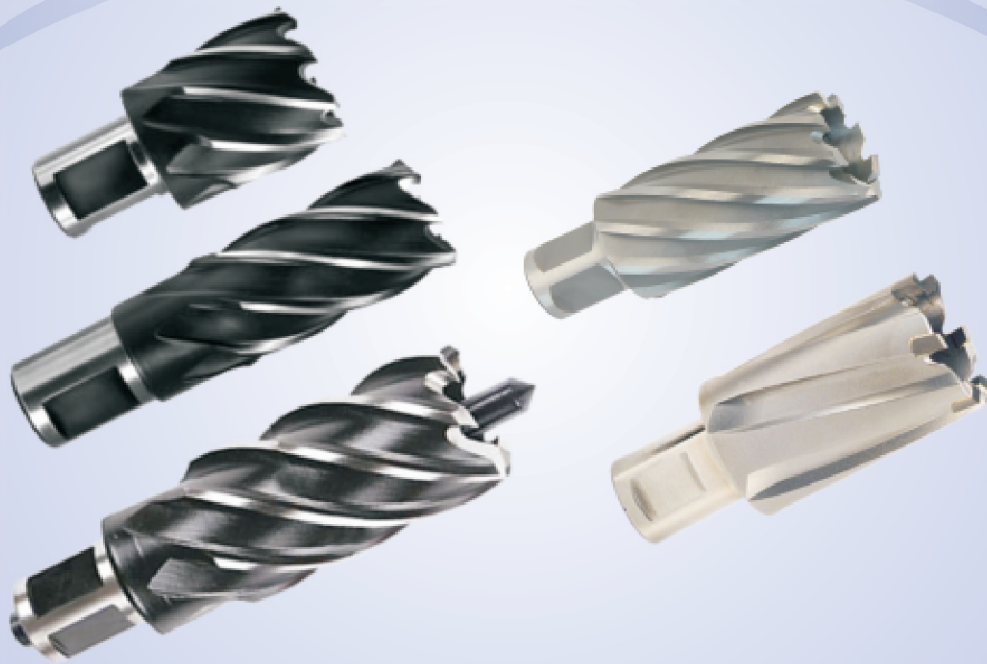

SIZE RANGE :

- Size : 11.0 mm To 60.0 mm
- Depth of Cut : 50.00 mm
- Special size / shank on request
- Coating on request

FEATURE :

- | | | |
|-------------------------------|------|--|
| Reduced Torque and thrust | ———— | Due to peripheral cutting |
| Minimizes kerf area | ———— | Unique center free design |
| Reducing HP and feed pressure | ———— | Alternating tooth geometry |
| Faster feed, less friction | ———— | Evenly distributes chip load to multiple cutting edges |
| Longer tool life | ———— | Special Heat treatment / surface treatment |
| Single pass-cutting, | ———— | No pre drilling required |
| High accuracy | ———— | Less Drifting- Precise Center locating |
| Smooth hole finish | ———— | Evenly distributes chip load to multiple cutting edges |

ANNULAR CUTTER



SIZE DIA. MM	HSS M2 - PRICE RS. / PIECE		HSS M42	TCT
	LENGTH 25 MM	LENGTH 50 MM	LENGTH 50 MM	LENGTH 50 MM
12-13	-	-	-	3,461
14-15	-	-	-	3,461
16*-17	1,701	2138	2,779	3,461
18-19	1,774	2219	2,886	3,461
20*-21	1,864	2310	3,003	3,461
22*-23	2,219	2629	3,417	3,569
24*-25	2,302	2783	3,619	3,569
26*-27	2,437	2938	3,819	4,031
28-29	2,629	3201	4,162	4,031
30*-31	2,756	3362	4,371	4,031
32*-33	2,883	3592	4,670	4,786
34-35	3,037	3830	4,977	4,786
36-37	3,447	4338	5,639	5,443
38-39	3,692	4602	5,983	5,443
40-41	4,047	5039	6,549	5,443
42-43	4,375	5448	7,081	6,647
44-45	4,802	5985	7,780	6,647
46-47	5,166	6431	8,358	7,173
48-49	5,448	6793	8,832	7,173
50-51	5,821	7666	9,966	7,523
52	6,203	7876	10,239	8,059
53	6,394	8131	10,569	8,399
54	6,594	8403	10,924	8,564
55	6,753	8631	11,219	8,772
56	6,993	8894	11,563	9,154
57	7,248	9108	11,841	9,439
58	7,431	9358	12,165	9,559
59	7,658	9567	12,437	9,724
60	7,890	9840	12,792	9,926

EJECTOR PIN

SIZE	TYPE	PRICE RS./ PEICE
6.34 X 73	CL 25	258
6.34 X 98	CL 50	348



HSS TAPS



PRODUCT RANGE

- Types** : Hand & Machine, Straight Flute, Spiral, Spiral Point, Nib, Ring Taps
Range : 2.0 mm to 140.0 mm
Grade of Steel : M2, M35 & M42
Product Standard : ISO 529, IS 6175, BS 949, DIN, ANSI, JIS
Thread Form : Metric, BSW, BSF, BA, BSP, UNF UNC, NPT...

APPLICATIONS

- Steel
- Stainless Steel
- Forged Steel
- Titanium & Nickel Alloy
- Aluminium

INDUSTRIES

- Automotive & Auto components
- Aerospace
- Heavy Engineering
- Power & Energy
- Railways
- Electronics & Electrical



HSS TAPS

HSS GROUND THREAD HAND TAPS - COARSE PITCH											IS 6175 - PART 1,2&3 -1992			
HSS GROUND THREAD MACHINE TAPS - COARSE PITCH											IS 6175 - PART 4 -1991			
HSS GROUND THREAD NUT TAPS - COARSE PITCH											IS 6175 - PART 5 -1992			
Code	Size	Hand & Short Machine Taps									Long Shank Machine Taps			Nut Taps
		IS 6175 Part 1			IS 6175 - Part 2			IS 6175 - Part 3			IS 6175 - Part 4			IS 6175 Part 5
		WTC_M	WTCPM	WHC_M	WHCPM	WHCTM	WUC_M	WUCPM	WUCTM	WMC_M	WMCPM	WMCTM	WVCNM	
		Str. Flute	Spiral Point	Str. Flute	Spiral Point	Spiral Flute	Str. Flute	Spiral Point	Spiral Flute	Type A,C,D	Type B	Spiral	Nut Tap	
Price Each Rs.														
010253A	M1.0 x 0.25	928	-	-	-	-	-	-	-	-	-	-	-	-
110253A	M1.1 x 0.25	928	-	-	-	-	-	-	-	-	-	-	-	-
120253A	M1.2 x 0.25	928	-	-	-	-	-	-	-	-	-	-	-	-
140303A	M1.4 x 0.30	788	-	-	-	-	-	-	-	-	-	-	-	-
160353A	M1.6 x 0.35	788	-	-	-	-	-	-	-	-	-	-	-	-
180353A	M1.8 x 0.35	788	-	-	-	-	-	-	-	-	-	-	-	-
020403A	M2.0 x 0.40	567	662	-	-	-	-	-	-	-	-	-	-	-
220453A	M2.2 x 0.45	567	662	-	-	-	-	-	-	-	-	-	-	-
230453A	M2.3 x 0.40	567	662	-	-	-	-	-	-	-	-	-	-	-
250453A	M2.5 x 0.45	567	662	-	-	-	-	-	-	-	-	-	-	-
260453A	M2.6 x 0.45	567	662	-	-	-	-	-	-	-	-	-	-	-
030503A	M3.0 x 0.50	-	-	341	428	465	383	454	526	751	886	622	-	-
350603A	M3.5 x 0.60	-	-	341	428	465	383	454	526	751	886	622	-	-
040703A	M4.0 x 0.70	-	-	341	428	465	383	454	526	751	886	622	-	-
450753A	M4.5 x 0.75	-	-	364	451	488	407	481	543	552	657	662	-	-
050803A	M5.0 x 0.80	-	-	364	451	488	407	481	543	537	657	662	-	-
061003A	M6.0 x 1.00	-	-	364	451	497	407	481	552	575	701	723	751	-
081253A	M8.0 x 1.25	-	-	438	522	551	488	594	680	626	763	786	850	-
101503A	M10 x 1.50	-	-	528	652	693	561	688	774	802	960	981	1129	-
121753A	M12 x 1.75	-	-	-	-	-	829	1,000	1,102	1,138	1,348	1,418	1735	-
142003A	M14 x 2.00	-	-	-	-	-	1,209	1,462	1,673	1,655	1,959	2,152	2402	-
162003A	M16 x 2.00	-	-	-	-	-	1,209	1,462	1,673	1,655	1,959	2,152	2402	-
182503A	M18 x 2.50	-	-	-	-	-	1,828	2,193	2,437	2,429	2,862	3,086	3670	-
202503A	M20 x 2.50	-	-	-	-	-	2,335	2,797	3,249	2,990	3,517	3,677	4911	-
222503A	M22 x 2.50	-	-	-	-	-	2,501	2,998	3,367	3,344	3,941	3,677	4974	-
243003A	M24 x 3.00	-	-	-	-	-	2,785	3,346	3,658	3,625	4,276	4,645	5646	-
253003A	M25 x 3.00	-	-	-	-	-	3,402	4,428	-	4,546	-	-	6754	-
273003A	M27 x 3.00	-	-	-	-	-	4,223	5,067	5,460	5,220	-	-	8672	-
303503A	M30 x 3.50	-	-	-	-	-	4,723	5,673	6,103	6,000	-	-	10929	-
333503A	M33 x 3.50	-	-	-	-	-	5,756	7,453	8,222	7,045	-	-	12053	-
364003A	M36 x 4.00	-	-	-	-	-	8,012	9,614	10,365	9,977	-	-	15606	-
394003A	M39 x 4.00	-	-	-	-	-	9,415	11,284	-	11,086	-	-	18595	-
424503A	M42 x 4.50	-	-	-	-	-	10,968	13,156	-	14,300	-	-	22149	-
454503A	M45 x 4.50	-	-	-	-	-	14,771	17,725	-	16,962	-	-	26714	-
485003A	M48 x 5.00	-	-	-	-	-	15,754	18,903	-	19,097	-	-	31079	-
525003A	M52 x 5.00	-	-	-	-	-	19,775	23,725	-	22,100	-	-	-	-
565503A	M56 x 5.50	-	-	-	-	-	28,143	33,766	-	30,944	-	-	-	-
605503A	M60 x 5.50	-	-	-	-	-	29,662	35,589	-	33,560	-	-	-	-
646003A	M64 x 6.00	-	-	-	-	-	31,200	37,442	-	37,877	-	-	-	-
686003A	M68 x 6.00	-	-	-	-	-	38,920	46,704	-	52,774	-	-	-	-
726003A	M72 x 6.00	-	-	-	-	-	52,239	-	-	-	-	-	-	-
766003A	M76 x 6.00	-	-	-	-	-	63,888	-	-	-	-	-	-	-
806003A	M80 x 6.00	-	-	-	-	-	77,171	-	-	-	-	-	-	-
856003A	M85 x 6.00	-	-	-	-	-	95,305	-	-	-	-	-	-	-
906003A	M90 x 6.00	-	-	-	-	-	118,949	-	-	-	-	-	-	-
956003A	M95 x 6.00	-	-	-	-	-	149,763	-	-	-	-	-	-	-
100603A	M100 x 6.00	-	-	-	-	-	185,062	-	-	-	-	-	-	-

A set of Non-serial taps consists of Taper, Second, Bottoming
 IS 6175 Part 1: Design will be supplied upto and including 2.6 mm
 IS 6175 Part 2: Design will be supplied from 3 mm to 10 mm including 10 mm
 IS 6175 Part 3: Design will be supplied above 10 mm.

Type"A" - 5 Deg. Taper with long taper lead
 Type"B" - 10 Deg. Taper lead angle with spiral point
 Type"C" - 20 Deg. Taper angle with short lead
 Type"D" - 10 Deg. Taper angle without spiral point

Items marked with * are stockable items. Remaining all items required minimum order value of Rs. 15000/- NETT OR
 1mm to 6mm 100 Nos. 7mm to 16mm 50 Nos. 18mm to 24mm 10 Nos. 26mm to 36 mm 05 Nos. & corresponding inch size.
 The tap sizes up to M6 will be supplied with male centers on both sides. Above M6 taps will be supplied with female centers on both sides.
 Serial Taps at 5% extra M35 Material 35% extra Left Hand Taps at 25% extra M42 Material 55% extra

HSS TAPS

HSS GROUND THREAD HAND TAPS - FINE PITCH										IS 6175 - PART 1,2&3 -1992	
HSS GROUND THREAD MACHINE TAPS - FINE PITCH										IS 6175 - PART 4 -1991	
HSS GROUND THREAD NUT TAPS - FINE PITCH										IS 6175 - PART 5 -1992	
Hand & Short Machine Taps								Long Shank Machine Taps		Nut Taps	
Code	Size	IS 6175 Part 1	IS 6175 - Part 2			IS 6175 - Part 3			IS 6175 - Part 4		IS 6175 Part 5
		WTF_M	WHF_M	WHFPM	WHFTM	WUF_M	WUFPM	WUFTM	WMF_M	WMF_M	WVFNM
		Str. Flute	Str. Flute	Spiral Point	Spiral Flute	Str. Flute	Spiral Point	Spiral Flute	Type A,C,D	Type B	Nut Tap
Price Each Rs.											
010023A	M1.0 x 0.20	974	-	-	-	-	-	-	-	-	-
110203A	M1.1 x 0.20	974	-	-	-	-	-	-	-	-	-
140203A	M1.4 x 0.20	885	-	-	-	-	-	-	-	-	-
160203A	M1.6 x 0.20	885	-	-	-	-	-	-	-	-	-
180203A	M1.8 x 0.20	885	-	-	-	-	-	-	-	-	-
020253A	M2.0 x 0.25	748	-	-	-	-	-	-	-	-	-
222503A	M2.2 x 0.25	748	-	-	-	-	-	-	-	-	-
250303A	M2.5 x 0.30	748	-	-	-	-	-	-	-	-	-
260303A	M2.6 x 0.30	748	-	-	-	-	-	-	-	-	-
030353A	M3.0 x 0.35		490	610	660	509	582	650	648	824	-
350353A	M3.5 x 0.35		490	610	660	509	582	650	690	768	-
040503A	M4.0 x 0.50		509	610	618	509	582	650	648	737	-
0450503A	M4.5 x 0.50		474	587	637	516	597	650	1,023	1,145	-
050503A	M5.0 x 0.50		498	594	660	519	597	650	655	768	-
060753A	M6.0 x 0.75		498	594	631	519	627	650	655	768	885
070753A	M7.0 x 0.75		573	-	770	592	714	740	751	885	1,086
080753A	M8.0 x 0.75		573	-	770	592	714	740	751	885	988
081003A	M8.0 x 1.00		519	622	671	573	646	740	693	821	988
091003A	M9.0 x 1.00		643	819	798	637	735	836	889	1,048	988
101003A	M10 x 1.00		584	716	798	637	735	836	866	965	1,297
101253A	M10 x 1.25		584	716	769	637	735	836	866	977	1,297
121003A	M12 x 1.00					974	1,103	1,300	1,247	1,467	2,030
121253A	M12 x 1.25					974	1,103	1,246	1,247	1,467	2,030
121503A	M12 x 1.50					974	1,103	1,246	1,247	1,467	2,030
141003A	M14 x 1.00					1,253	1,501	1,785	1,610	1,906	3,029
141253A	M14 x 1.25					1,279	1,542	1,747	1,642	1,938	3,029
141503A	M14 x 1.50					1,213	1,490	1,665	1,544	1,823	3,029
161003A	M16 x 1.00					1,250	1,539	1,747	1,734	2,049	3,029
161503A	M16 x 1.50					1,214	1,490	1,665	1,544	1,959	3,029
181003A	M18 x 1.00					2,282	2,550	2,718	2,832	3,341	4,287
181503A	M18 x 1.50					2,082	2,329	2,718	2,598	3,305	4,287
182003A	M18 x 2.00					2,282	2,550	2,718	2,832	3,341	4,287
201503A	M20 x 1.50					2,634	2,940	3,470	3,391	4,005	5,500
202003A	M20 x 2.00					2,622	3,391	3,470	3,736	4,740	5,500
221503A	M22 x 1.50					2,874	3,205	3,728	3,519	4,156	5,839
222003A	M22 x 2.00					3,091	3,719	3,728	3,793	4,807	5,839
241503A	M24 x 1.50					3,144	3,508	4,126	3,928	4,636	6,939
242003A	M24 x 2.00					3,138	4,042	4,126	4,139	5,251	6,939
251503A	M25 x 1.50					3,365	4,300	-	5,008	5,933	7,802
252003A	M25 x 2.00					3,331	4,300	-	5,008	5,933	-
261503A	M26 x 1.50					3,508	4,395	-	5,148	6,076	-
262003A	M26 x 2.00					3,508	4,395	-	5,148	6,076	-
271503A	M27 x 1.50					4,686	5,654	-	6,173	7,508	-
272003A	M27 x 2.00					4,686	5,654	-	6,173	7,508	-
281503A	M28 x 1.50					4,702	5,880	-	6,654	9,138	-
282003A	M28 x 2.00					4,702	5,880	-	6,654	9,138	-
301503A	M30 x 1.50					5,275	6,341	-	6,942	9,002	-
302003A	M30 x 2.00					5,275	6,348	-	6,942	9,002	-
303003A	M30 x 3.00					5,286	6,348	-	6,942	9,002	-
321503A	M32 x 1.50					5,619	6,959	-	7,667	9,919	-
322003A	M32 x 2.00					5,619	6,959	-	7,667	9,919	-

HSS TAPS

Hand & Short Machine Taps						Long Shank Machine Taps			Nut Taps		
Code	Size	IS 6175 Part 1	IS 6175 - Part 2		IS 6175 - Part 3			IS 6175 - Part 4		IS 6175 Part 5	
		WTF_M Str. Flute	WHF_M Str. Flute	WHFPM Spiral Point	WHFTM Spiral Flute	WUF_M Str. Flute	WUFPM Spiral Point	WUFTM Spiral Flute	WMF_M Type A,C,D	WMF_M Type B	WVFNM Nut Tap
Price Each Rs.											
331503A	M33 x 1.50	-	-	-	-	6,447	8,064	-	8,394	10,465	-
332003A	M33 x 2.00	-	-	-	-	6,447	8,064	-	8,394	10,465	-
333003A	M33 x 3.00	-	-	-	-	6,447	8,064	-	8,394	10,465	-
351503A	M35 x 1.50	-	-	-	-	8,960	11,154	-	11,560	14,565	-
361503A	M36 x 1.50	-	-	-	-	8,956	11,154	-	11,560	14,565	-
362003A	M36 x 2.00	-	-	-	-	8,956	11,154	-	11,560	14,565	-
363003A	M36 x 3.00	-	-	-	-	8,945	11,154	-	11,560	14,565	-
391503A	M39 x 1.50	-	-	-	-	11,161	-	-	-	-	-
392003A	M39 x 2.00	-	-	-	-	11,161	-	-	-	-	-
393003A	M39 x 3.00	-	-	-	-	11,161	-	-	-	-	-
421503A	M42 x 1.50	-	-	-	-	12,405	-	-	-	-	-
422003A	M42 x 2.00	-	-	-	-	12,405	-	-	-	-	-
423003A	M42 x 3.00	-	-	-	-	12,405	-	-	-	-	-
424003A	M42 x 4.00	-	-	-	-	12,405	-	-	-	-	-
451503A	M45 x 1.50	-	-	-	-	17,196	-	-	-	-	-
452003A	M45 x 2.00	-	-	-	-	17,196	-	-	-	-	-
453003A	M45 x 3.00	-	-	-	-	17,196	-	-	-	-	-
454003A	M45 x 4.00	-	-	-	-	17,196	-	-	-	-	-
481503A	M48 x 1.50	-	-	-	-	16,707	-	-	-	-	-
482003A	M48 x 2.00	-	-	-	-	16,707	-	-	-	-	-
483003A	M48 x 3.00	-	-	-	-	16,707	-	-	-	-	-
484003A	M48 x 4.00	-	-	-	-	16,707	-	-	-	-	-
501503A	M50 x 1.50	-	-	-	-	19,753	-	-	-	-	-
502003A	M50 x 2.00	-	-	-	-	19,753	-	-	-	-	-
503003A	M50 x 3.00	-	-	-	-	19,753	-	-	-	-	-
521503A	M52 x 1.50	-	-	-	-	22,264	-	-	-	-	-
522003A	M52 x 2.00	-	-	-	-	22,264	-	-	-	-	-
523003A	M52 x 3.00	-	-	-	-	22,264	-	-	-	-	-
524003A	M52 x 4.00	-	-	-	-	22,264	-	-	-	-	-
561503A	M56 x 1.50	-	-	-	-	29,049	-	-	-	-	-
562003A	M56 x 2.00	-	-	-	-	29,049	-	-	-	-	-
563003A	M56 x 3.00	-	-	-	-	29,049	-	-	-	-	-
564003A	M56 x 4.00	-	-	-	-	29,049	-	-	-	-	-
601503A	M60 x 1.50	-	-	-	-	32,411	-	-	-	-	-
602003A	M60 x 2.00	-	-	-	-	32,411	-	-	-	-	-
603003A	M60 x 3.00	-	-	-	-	33,143	-	-	-	-	-
604003A	M60 x 4.00	-	-	-	-	33,143	-	-	-	-	-
641503A	M64 x 1.50	-	-	-	-	34,531	-	-	-	-	-
642003A	M64 x 2.00	-	-	-	-	34,531	-	-	-	-	-
643003A	M64 x 3.00	-	-	-	-	35,153	-	-	-	-	-
644003A	M64 x 4.00	-	-	-	-	35,153	-	-	-	-	-
681503A	M68 x 1.50	-	-	-	-	43,725	-	-	-	-	-
682003A	M68 x 2.00	-	-	-	-	43,725	-	-	-	-	-
683003A	M68 x 3.00	-	-	-	-	32,554	-	-	-	-	-
684003A	M68 x 4.00	-	-	-	-	44,284	-	-	-	-	-
724003A	M72 x 4.00	-	-	-	-	48,754	-	-	-	-	-

A set of Non-serial taps consists of Taper, Bottoming
 IS 6175 Part 1: Design will be supplied upto and including 2.6 mm
 IS 6175 Part 2: Design will be supplied from 3 mm to 10 mm including 10 mm
 IS 6175 Part 3: Design will be supplied above 10 mm.

Type"A" - 5 Deg. Taper with long taper lead
 Type"B" - 10 Deg. Taper lead angle with spiral point
 Type"C" - 20 Deg. Taper angle with short lead
 Type"D" - 10 Deg. Taper angle without spiral point

Serial Taps at 5% extra M35 Material 35% extra
 Left Hand Taps at 25% extra. M42 Material 55% extra
 The tap sizes up to M6 will be supplied with male centers on both sides. Above M6 taps will be supplied with female centers on both sides.

Items marked with * are stockable items. Remaining all items required minimum order value of Rs. 15000/- Nett OR
 1mm to 6mm 100 Nos. 7mm to 16mm 50 Nos. 18mm to 24mm 10 Nos. 26mm to 36 mm 05 Nos.

HSS HAND TAPS - BSW(WTK_) & BSF (WTL_)			BS949 (Part 1) - 1992			
Part Code		Size	Straight Flute	Spiral Point	Spiral flute	Nut taps
BSW(WTK_)	BSF(WTL_)					
I018406A*	-	1/8"	355	428	503	-
I316246A*	I316326A	3/16"	355	446	480	-
I014206A*	I014266A	1/4"	372	446	530	778
I516186A*	I516226A	5/16"	417	524	556	848
I038166A*	I038206A	3/8"	509	627	685	1,030
I716146A*	I716186A	7/16"	655	812	906	1,388
I012126A*	I012166A	1/2"	833	1,000	1,099	1,729
I916126A	I916166A	9/16"	1,213	1,462	1,691	2,402
I058116A*	I058146A	5/8"	1,213	1,462	1,691	2,402
I116116A	I116146A	11/16"	1,772	2,186	2,387	3,088
I034106A*	I034126A	3/4"	1,842	2,218	2,454	3,677
I078096A	I078116A	7/8"	2,546	3,050	3,367	4,971
I100086A*	I100106A	1"	3,191	3,834	4,050	6,479
I118076A	I118096A	1.1/8"	4,287	5,144	-	8,724
I114076A*	I114096A	1.1/4"	5,168	6,202	-	12,976
I138066A	I138086A	1.3/8"	6,666	7,999	-	15,566
I112066A	I112086A	1.1/2"	8,012	9,607	-	-

HSS HAND TAPS - UNC(WTG_) & UNF(WTJ_)			BS949 (Part 1) - 1992			
Part Code		Size	Straight Flute	Spiral Point	Spiral flute	Nut taps
UNC(WTG_)	UNF(WTJ_)					
-	N000806A	No 0	833	-	-	-
N001646A	N001726A	No 1	833	-	-	-
N002566A	N002646A	No 2	587	-	-	-
N004406A	N004486A	No 4	399	-	-	-
N005406A	N005446A	No 5	399	481	480	-
N006326A	N006406A	No 6	399	481	480	-
N008326A	N008366A	No 8	399	481	480	-
N010246A	N010326A	No 10	399	481	480	-
N012246A	N012286A	No 12	493	587	516	-
I018286A	I018406A	1/8"	355	428	503	-
I316246A	I316326A	3/16"	355	446	480	-
I014206A*	I014286A	1/4"	369	454	530	777
I516186A*	I516246A	5/16"	418	524	557	848
I038166A*	I038246A	3/8"	509	627	685	1,030
I716146A	I716206A	7/16"	655	812	906	1,387
I012136A*	I012206A	1/2"	833	1,000	1,099	1,730
I916126A	I916186A	9/16"	1,213	1,462	1,692	2,402
I058116A*	I058186A*	5/8"	1,213	1,462	1,692	2,402
I116116A	I116116A	11/16"	1,772	2,185	2,388	3,087
I034106A*	I034166A	3/4"	1,842	2,218	2,454	3,676
I078096A	I078146A	7/8"	2,546	3,050	3,367	4,971
I100086A*	I100126A*	1"	3,191	3,834	4,050	6,479
I118076A	I118126A	1.1/8"	4,287	5,141	-	8,724
I114076A	I114126A	1.1/4"	5,167	6,199	-	12,975
I138066A	I138126A	1.3/8"	6,666	8,000	-	15,566
I112066A	I112126A	1.1/2"	8,012	9,605	-	-

• Serial Taps at 5% extra / Left Hand Taps at 25% extra

• M35 Material 35% extra / M42 Material 55% extra

HSS HAND TAPS - BSCy (Code : WHQ_)				BS949 (Part II) - 1951		
Code	Size	Straight flute	Code	Size	Straight flute	
Price Each Rs.						
N11SWG6A	14 Swg	646	I516306A	5/16"	552	
N10SWG6A	10 Swg	343	I716266A	7/16"	832	
N09SWG6A	9 Swg	343	I012266A	1/2"	1,040	
I532326A	5/32"	402	I916206A	9/16"	1,650	
I316326A	3/16"	402	I100246A	1"	3,271	
I732266A	7/32"	430	O167096A	1.370"	6,891	
I014266A	1/4"	454	O137596A	1.375"	6,891	

- The manufacturing range of BSCy taps is 14 Swg upwards.
- M35 Material 35% extra • M42 Material 55% extra

HSS HAND TAPS - BA (Code : WTM_)				BS949 (Part 1) - 1992			
Code	Size	Straight flute	Spiral point	Code	Size	Straight flute	Spiral point
Price Each Rs.							
N0BA106A	No. 0	439	526	N8BA436A	No. 8	719	693
N1BA906A	No. 1	439	526	10BA356A	No. 10	859	998
N2BA816A	No. 2	388	475	11BA316A	No. 11	1,331	1,599
N3BA736A	No. 3	388	475	12BA286A	No. 12	1,331	1,599
N4BA666A	No. 4	388	475	13BA256A	No. 13	1,396	-
N5BA596A	No. 5	388	475	14BA236A	No. 14	1,396	-
N6BA536A	No. 6	428	475	-	-	-	-

- All the tap sizes will be supplied with male centers on both sides.

HSS PIPE TAPS				BS949 (Part II) - 1969			
Parallel Thread				Taper Thread			
Code	Size	WHP_	NPS	WHU_	WHR_	WHS_	WHT_
		BSP		NPSF	BSPT	NPT	NPTF
Price Each Rs.							
I018286A	1/8"	549	648	780	801	821	861
I014196A	1/4"	855	1,124	1,371	1,396	1,437	1,619
I038196A	3/8"	1,286	1,441	1,739	1,795	1,825	2,111
I012146A	1/2"	1,877	2,096	2,520	2,687	2,745	3,086
I058146A	5/8"	2,129	-	-	-	-	-
I034146A	3/4"	2,804	3,086	3,687	3,983	4,066	4,551
I078146A	7/8"	3,560	-	-	-	-	-
I001116A	1"	4,422	5,212	6,236	6,193	6,349	7,091
I114116A	1.1/4"	6,820	8,055	9,666	8,863	9,066	10,452
I112116A	1.1/2"	8,526	10,047	12,050	10,842	11,247	-
I134116A	1.3/4"	10,663	12,531	15,031	-	-	-
I200116A	2"	15,562	17,957	21,547	19,853	20,329	-
I214116A	2.1/4"	26,545	-	-	-	-	-
I212116A	2.1/2"	37,874	-	-	57,895	57,895	-
I234116A	2.3/4"	42,580	-	-	-	-	-
I300116A	3"	47,992	-	-	75,347	75,347	-
I312116A	3.1/2"	63,071	-	-	100,603	100,603	-
I400116A	4"	79,373	-	-	126,932	126,932	-

- Items marked with * are stockable items. Remaining all items required Minimum order value of Rs. 15000/- Nett.
From Size 1/8" to 5/8" 50 Nos. each 3/4" to 1" 10 Nos. each 1.1/4" to 2.1/4" 5 Nos each

HSS NIB TAPS TO OUR STANDARD - (Code : XNC_)					Price Each Rs.		
	Size	Straight flute		Code	Size	Straight flute	
		M35	GV 3			M35	GV3
M030503D	M3 x 0.5	618	744	M081253D	M8 x1.25	804	978
M040703D	M4 x 0.7	630	763	M101503D	M10 x1.5	1,017	1,202
M050803D	M5 x 0.8	669	789	M121753D	M12 x1.75	1,195	1,370
M061003D	M6 x 1.0	743	789	-	-	-	-

- The above taps will be supplied with TiCN / TiAlN Coating
- The tap sizes upto M6" will be supplied with malecenters on both sides, above M6 taps will be supplied with female centers on both sides
- The tap sizes up to M6 will be supplied with 3 flutes, above M6 will be supplied with 5 flute. Any other style of Nib taps can be offered on specific request.
- **Items marked with * are stockable items. Remaining all items required Minimum order value of Rs. 15000/ Nett. or 5 Nos. for size whichever is higher.**
- The manufacturing range of Nib taps is M3 upwards , for the sizes above M12, quotation will be given on Specific request

UN TAPS (WTV_)				BS949 (Part1) -1992	
Part Code	Size	Price Each Rs.	Part Code	Size	Price Each Rs.
I118086A	1.1/8" X 8	4,287	I134086A	1.3/4" X 8	10,962
I114086A	1.1/4" X 8	5,167	I178086A	1.7/8" X 8	13,248
I138086A	1.3/8" X 8	6,666	I200086A	2" X 8	17,277
I112086A	1.1/2" X 8	8,012	I214086A	2.1/4" X 8	23,799
I158086A	1.5/8" X 8	9,368	I212086A	2.1/2" X 8	30,250

HSS GROUND THREAD HAND TAPS-COARSE PITCH - HELICOIL (WHR_)				IS 6175 : 1992	
Part Code	Size	Price Each Rs.	Part Code	Size	Price Each Rs.
M030503A	M3 X 0.50	341	M142003A	M14 X 2.00	1,828
M040704A	M4 X 0.70	362	M162003A	M16 X 2.00	1,828
M050805A	M5 X 0.80	435	M182503A	M18 X 2.50	2,335
M061006A	M6 X 1.00	435	M202503A	M20 X 2.50	2,501
M081253A	M8 X 1.25	528	M222503A	M22 X 2.50	2,785
M101503A	M10X 1.50	829	M243003A	M24 X 3.00	4,223
M121753A	M12X 1.75	1,209	M273003A	M27 X 3.00	4,723
		-	M303503A	M30 X 3.50	5,521

- Taps with different coatings can be provided with additional cost at actuals.
- Taps for various application like cast iron, Aluminium, Brass etc. can be supplied on demand.
- Taps of DIN 371, DIN 374, DIN 376, DIN 2184, JIS 4430 1998, ISO 529 1993 can be supplied on demand.

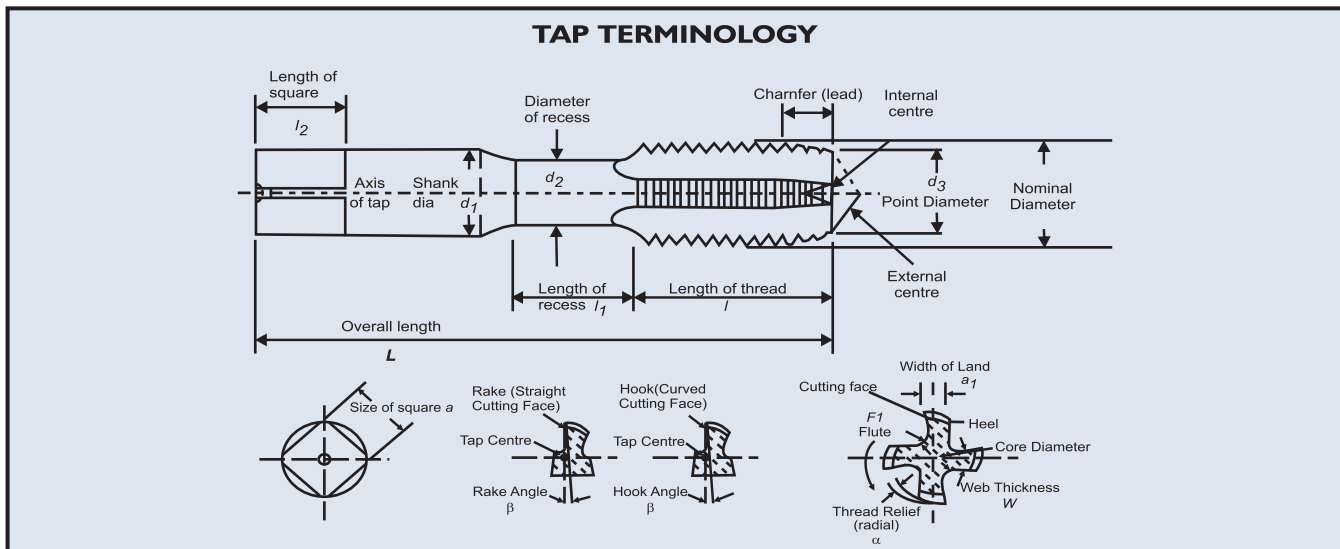



MIRANDA TOOLS

Premium quality cutting tools

DORMER PRAMET

New Launch

**MIRANDA
EDGE**

**HIGH
PERFORMANCE
PLATINUM
CUT TAPS**



MIRANDA EDGE - PLATINUMCUT TAPS									
Size	SPPT			SPIREX			BOT		
	LIST PRICE- Rs. / Each								
	UNCOATED	TIN	TIALN	UNCOATED	TIN	TIALN	UNCOATED	TIN	TIALN
	MA1	MA2	MA3	MB1	MB2	MB3	MC1	MC2	MC3
M3 x 0.5	600	690	721	689	791	826	500	575	601
M4 x 0.7	600	690	721	689	791	826	500	575	601
M5 x 0.8	629	723	755	721	829	865	526	605	631
M6 x 1.0	629	723	755	721	829	865	526	605	631
M8 x 1.0	-	-	-	896	1,030	1,075	-	-	-
M8 x 1.25	706	811	847	808	928	969	590	677	707
M10 x 1.0	1,014	1,166	1,217	1,162	1,336	1,394	-	-	-
M10 x 1.25	1,014	1,166	1,217	1,162	1,336	1,394	846	974	1,017
M10 x 1.5	872	1,003	1,047	1,000	1,150	1,201	729	838	875
M12 x 1.0	1,570	1,804	1,884	1,796	2,067	2,155	-	-	-
M12 x 1.25	1,570	1,804	1,884	1,796	2,067	2,155	1,306	1,501	1,567
M12 x 1.50	1,570	1,804	1,884	1,796	2,067	2,155	1,306	1,501	1,567
M12 x 1.75	1,346	1,547	1,614	1,541	1,773	1,849	1,122	1,290	1,347

High Performance Platinum Cut Taps

Type	picture	Range	Series	Thread form	Blank Standard	Treatment	Material	Tapping type	Application
Straight Flute		M3-M12	MC 1	M	IS -6175/ISO 529	Bright	HSS-E	Blind/ Through	Medium to high tensile steel , Alloy steel , MS , general application
			MC2	M	IS -6175/ISO 529	TiN			
			MC3	M	IS -6175/ISO 529	TiAlN			
Straight Flute for cast Iron		M3-M12	CI MC 1	M	IS -6175/ISO 529	Bright	HSS-E	Blind/ Through	cast iron , SG iron , abrasive type steel
			CI MC 2	M	IS -6175/ISO 529	TiN			
			CI MC 3	M	IS -6175/ISO 529	TiAlN			
Spiral Point		M3-M12	MA 1	M	IS -6175/ISO 529	Bright	HSS-E	Through holes	Medium to high tensile steel , Alloy steel , MS , general application
			MA 2	M	IS -6175/ISO 529	TiN			
			MA3	M	IS -6175/ISO 529	TiAlN			
Spiral Flute		M3-M12	MB 1	M	IS -6175/ISO 529	Bright	HSS-E	Blind Holes	Medium to high tensile steel , Alloy steel , MS , general application
			MB2	M	IS -6175/ISO 529	TiN			
			MB3	M	IS -6175/ISO 529	TiAlN			

Recommended Parameter

Material	RC Value	HB value	Recommended Mtr / min	
			HSS-E	
			Uncoated	Coated
Structural steels, free-cutting steels Case hardened steels, heat-treatable steels	<20	<236	9-15	12-20
	<25	<256	9-13	11-18
	<30	<286	6-9	9-16
	<35	<326	5-8	6-10
Stainless- and acid-resistant steels, sulphured austenitic martensitic	<38	<386	4-8	6-12
	<25	<186	8-13	12-16
	<35	<256	6-9	9-12
	<36	<286	6-9	7-12
Alloyed case hardened steels Alloyed heat-treatable steels Alloyed tool steels High speed tool steels	<35	<326	3-6	6-9
	<38	<386	3-6	9-12
	<25	<256	8-10	9-15
	<36	<286	5-8	6-9
Cast iron Spheroidal graphite iron Malleable cast iron	<38	<386	3-5	4-9
	<25	<186	15-20	18-25
	<35	<256	9-12	14-18
Brass	<35	<326	5-10	6-12
			9-13	-
			9-15	-

TUNGSTEN CARBIDE TIPPED TOOLS





ISO 1 (110) BAR TURNING TOOLS	SHANK SIZE H X B (mm)	L (mm)	RIGHT HAND (RH)		LEFT HAND (LH)		PRICE RS. / PIECE
			ORDER CODE - MIR100				
			P30	K20	P30	K20	
	1010	90	1004RC	1001RC	1004LC	1001LC	331
	1212	100	1014RC	1011RC	1014LC	1011LC	361
	1616	110	1034RC	1031RC	1034LC	1031LC	487
	2020	125	1054RC	1051RC	1054LC	1051LC	776
	2525	140	1074RC	1071RC	1074LC	1071LC	1164
	3232	170	1094RC	1091RC	1094LC	1091LC	1899
	4040	200	1114RC	1111RC	1114LC	1111LC	3912
	5050	240	1134RC	1131RC	1134LC	1131LC	8002
	1610	110	1024RC	1021RC	1024LC	1021LC	388
	2012	125	1044RC	1041RC	1044LC	1041LC	536
	2516	140	1064RC	1061RC	1064LC	1061LC	719
	3220	170	1084RC	1081RC	1084LC	1081LC	1226
	4025	200	1104RC	1101RC	1104LC	1101LC	1971
	5032	240	1124RC	1121RC	1124LC	1121LC	4495
	6040	280	1144RC	1141RC	1144LC	1141LC	8176
ISO 2 (111) CRANKED TURNING & FACING TOOLS	1010	90	1204RC	1201RC	1204LC	1201LC	361
	1212	100	1214RC	1211RC	1214LC	1211LC	396
	1616	110	1234RC	1231RC	1234LC	1231LC	548
	2020	125	1254RC	1251RC	1254LC	1251LC	760
	2525	140	1274RC	1271RC	1274LC	1271LC	1142
	3232	170	1294RC	1291RC	1294LC	1291LC	1965
	4040	200	1314RC	1311RC	1314LC	1311LC	3827
	5050	240	1334RC	1331RC	1334LC	1331LC	8120
	1610	110	1224RC	1221RC	1224LC	1221LC	428
	2012	125	1244RC	1241RC	1244LC	1241LC	578
	2516	140	1264RC	1261RC	1264LC	1261LC	776
	3220	170	1284RC	1281RC	1284LC	1281LC	1234
	4025	200	1304RC	1301RC	1304LC	1301LC	2209
	5032	240	1324RC	1321RC	1324LC	1321LC	4585
	6040	280	1344RC	1341RC	1344LC	1341LC	8323
ISO 3 (123) CRANKED FINISHING TOOLS	1010	90	2204RC	2201RC	2204LC	2201LC	361
	1212	100	2214RC	2211RC	2214LC	2211LC	396
	1616	110	2234RC	2231RC	2234LC	2231LC	548
	2020	125	2254RC	2251RC	2254LC	2251LC	760
	2525	140	2274RC	2271RC	2274LC	2271LC	1142
	3232	170	2294RC	2291RC	2294LC	2291LC	1965
	4040	200	2314RC	2311RC	2314LC	2311LC	3827
	5050	240	2334RC	2331RC	2334LC	2331LC	8120
	1610	110	2224RC	2221RC	2224LC	2221LC	428
	2012	125	2244RC	2241RC	2244LC	2241LC	578

ISO 3 (123) CRANKED FINISHING TOOLS	SHANK SIZE H X B (mm)	L (mm)	RIGHT HAND (RH)		LEFT HAND (LH)		PRICE RS./ PIECE	
			ORDER CODE - MIR100					
			P30	K20	P30	K20		
	2516	140	2264RC	2261RC	2264LC	2261LC	777	
	3220	170	2284RC	2281RC	2284LC	2281LC	1,234	
	4025	200	2304RC	2301RC	2304LC	2301LC	2,209	
	5032	240	2324RC	2321RC	2324LC	2321LC	4,585	
	6040	280	2344RC	2341RC	2344LC	2341LC	8,323	
ISO 4 (127) RECESSING TOOLS	NEUTRAL (NH)							
		1010	90	2604SC	2601SC			361
		1212	100	2614SC	2611SC			444
		1616	110	2634SC	2631SC			660
		2020	125	2654SC	2651SC			992
		2525	140	2674SC	2671SC			1,618
		3232	170	2694SC	2691SC			3,192
		4040	200	2714SC	2711SC			7,890
		5050	240	2076SC	2731SC			14,167
		1610	110	2624SC	2621SC			487
		2012	125	2644SC	2641SC			520
		2516	140	2664SC	2661SC			765
		3220	170	2684SC	2681SC			1,476
		4025	200	2704SC	2701SC			2,563
	5032	240	2724SC	2721SC			4,874	
ISO 5 (126) CRANKED FACING TOOLS			RIGHT HAND (RH)		LEFT HAND (LH)			
		1010	90	2404RC	2401RC	2404LC	2401LC	361
		1212	100	2414RC	2411RC	2414LC	2411LC	396
		1616	110	2434RC	2430RC	2434LC	2431LC	548
		2020	125	2454RC	2451RC	2454LC	2451LC	760
		2525	140	2474RC	2471RC	2474LC	2471LC	1,142
		3232	170	2494RC	2491RC	2494LC	2491LC	1,966
		4040	200	2426RC	2511RC	2426LC	2511LC	3,827
		5050	240	2428RC	2531RC	2428LC	2531LC	8,120
		1610	110	2424RC	2421RC	2424LC	2421LC	428
		2012	125	2444RC	2441RC	2444LC	2441LC	579
		2516	140	2464RC	2461RC	2464LC	2461LC	777
		3220	170	2484RC	2481RC	2484LC	2481LC	1,234
		4025	200	2504RC	2501RC	2504LC	2501LC	2,212
	5032	240	2524RC	2521RC	2524LC	2521LC	4,585	
ISO 6 (117) CRANKED KNIFE TOOLS		1010	90	2004RC	2001RC	2004LC	2001LC	361
		1212	100	2014RC	2011RC	2014LC	2011LC	396
		1616	110	2034RC	2031RC	2034LC	2031LC	548
		2020	125	2054RC	2051RC	2054LC	2051LC	760
		2525	140	2074RC	2071RC	2074LC	2071LC	1,142
		3232	170	2094RC	2091RC	2094LC	2091LC	1,966
	4040	200	2114RC	2111RC	2114LC	2111LC	3,827	

ISO 6 (117) CRANKED KNIFE TOOLS	SHANK SIZE H X B (mm)	L (mm)	RIGHT HAND (RH)		LEFT HAND (LH)		PRICE RS./ PIECE
			ORDER CODE - MIR100				
			P30	K20	P30	K20	
	5050	240	2134RC	2131RC	2134LC	2131LC	8,120
	1610	110	2024RC	2021RC	2024LC	2021LC	428
	2012	125	2044RC	2041RC	2044LC	2041LC	579
	2516	140	2064RC	2061RC	2064LC	2061LC	777
	3220	170	2084RC	2081RC	2084LC	2081LC	1,461
	4025	200	2104RC	2101RC	2104LC	2101LC	2,218
	5032	240	2124RC	2121RC	2132LC	2121LC	4,591
ISO 7 (150) PARTING OFF TOOLS	1010	90	5103RC	5201RC	5204LC	5201LC	431
	1212	100	5214RC	5211RC	5214LC	5211LC	490
	1616	110	5314RC	5231RC	5314LC	5231LC	545
	2020	125	5254RC	5180RC	5254LC	5180LC	601
	2525	140	5071RC	5061RC	5071LC	5061LC	805
	3232	170	5274RC	5271RC	5274LC	5271LC	1,279
	1006	90	5104RC	5101RC	5104LC	5101LC	361
	1208	100	5114RC	5111RC	5114LC	5111LC	428
	1610	110	5124RC	5121RC	5124LC	5121LC	454
	2012	125	5134RC	5131RC	5134LC	5131LC	503
	2516	140	5144RC	5141RC	5144LC	5141LC	666
	3220	170	5154RC	5151RC	5154LC	5151LC	1,070
	4025	200	5164RC	5161RC	5164LC	5161LC	1,768
5032	240	5166RC	5301RC	5304LC	5301LC	2,501	
ISO 8 (130) BORING TOOLS (SQUARE)	0808	125	2804RC	2801RC	2804LC	2801LC	664
	1010	150	2814RC	2811RC	2814LC	2811LC	712
	1212	180	2827RC	2823RC	2827LC	2823LC	777
	1616	210	2834RC	2831RC	2834LC	2831LC	933
	2020	250	2844RC	2841RC	2844LC	2841LC	1,142
	2525	300	2854RC	2851RC	2854LC	2851LC	2,133
	3232	355	2864RC	2861RC	2864LC	2861LC	2,773
	4040	400	2874RC	2871RC	2874LC	2871LC	4,028
5050	450	2878RC	2877RC	2878LC	2877LC	7,396	
ISO 8 (131) BORING TOOLS (ROUND)	Ø08	125	2904RC	2901RC	2904LC	2901LC	616
	Ø10	150	2914RC	2911RC	2914LC	2911LC	664
	Ø12	180	2924RC	2921RC	2924LC	2921LC	712
	Ø16	210	2934RC	2931RC	2934LC	2931LC	818
	Ø20	250	2944RC	2941RC	2944LC	2941LC	999
	Ø25	300	2954RC	2951RC	2954LC	2951LC	1,899
Ø32	355	2964RC	2961RC	2964LC	2961LC	2,418	

ISO 9 (135) BORING TOOLS (SQUARE)	SHANK SIZE H X B (mm)	L (mm)	RIGHT HAND (RH)		LEFT HAND (LH)		PRICE RS./ PIECE
			ORDER CODE - MIR100				
			P30	K20	P30	K20	
	0808	125	3004RC	3001RC	3004LC	3001LC	664
	1010	150	3014RC	3011RC	3014LC	3011LC	712
	1212	180	3024RC	3021RC	3024LC	3021LC	777
	1616	210	3034RC	3031RC	3034LC	3031LC	933
	2020	250	3044RC	3041RC	3044LC	3041LC	1,142
	2525	300	3054RC	3051RC	3054LC	3051LC	2,133
	3232	355	3064RC	3061RC	3064LC	3061LC	2,773
	4040	400	3068RC	3062RC	3068LC	3062LC	4,028
ISO 9 (136) BORING TOOLS (ROUND)	Ø08	125	3104RC	3101RC	3104LC	3101LC	616
	Ø10	150	3114RC	3111RC	3114LC	3111LC	664
	Ø12	180	3124RC	3121RC	3124LC	3121LC	712
	Ø16	210	3134RC	3131RC	3134LC	3131LC	818
	Ø20	250	3144RC	3141RC	3144LC	3141LC	999
	Ø25	300	3154RC	3151RC	3154LC	3151LC	1,899
	Ø32	355	3164RC	3161RC	3164LC	3161LC	2,418
113 - STRAIGHT ROUND NOSE TURNING TOOLS	NEUTRAL (NH)						
	1010	90	1404SC	1401SC			361
	1212	100	1414SC	1411SC			396
	1616	110	1434SC	1431SC			557
	2020	125	1454SC	1451SC			864
	2525	140	1474SC	1471SC			1,246
	3232	170	1494SC	1491SC			2,317
	4040	200	1614SC	1506SC			4,296
	1610	110	1424SC	1421SC			431
	2012	125	1444SC	1441SC			528
	2516	140	1464SC	1461SC			722
	3220	170	1484SC	1481SC			1,004
	4025	200	1504SC	1501SC			2,015
	5032	240	0057AC	0057SC			3,781
115 CRANKED ROUND NOSE TURNING TOOLS.			RIGHT HAND (RH)		LEFT HAND (LH)		
	1010	90	1604RC	1601RC	1604LC	1601LC	396
	1212	100	1614RC	1611RC	1614LC	1611LC	422
	1616	110	1634RC	1631RC	1634LC	1631LC	579
	2020	125	1654RC	1651RC	1654LC	1651LC	864
	2525	140	1674RC	1671RC	1674LC	1671LC	1,246
	3232	170	1694RC	1691RC	1694LC	1691LC	2,418
	4040	200	1714RC	1711RC	1714LC	1711LC	4,480
	1610	110	1624RC	1621RC	1624LC	1621LC	475
	2012	125	1644RC	1641RC	1644LC	1641LC	557
	2516	140	1664RC	1661RC	1664LC	1661LC	760
	3220	170	1684RC	1681RC	1684LC	1681LC	1,056
	4025	200	1704RC	1701RC	1704LC	1701LC	2,105

116 - BAR TURNING TOOLS	SHANK SIZE H X B (mm)	L (mm)	RIGHT HAND (RH)		LEFT HAND (LH)		PRICE RS./ PIECE
			ORDER CODE - MIR100				
			P30	K20	P30	K20	
	1010	90	1804RC	1801RC	1804LC	1801LC	326
	1212	100	1814RC	1811RC	1814LC	1811LC	361
	1616	110	1834RC	1831RC	1834LC	1831LC	481
	2020	125	1854RC	1851RC	1854LC	1851LC	712
	2525	140	1874RC	1871RC	1874LC	1871LC	1,102
	3232	170	1894RC	1891RC	1894LC	1891LC	1,904
	4040	200	1914RC	1911RC	1914LC	1911LC	3,761
	5050	240	1934RC	1931RC	1934LC	1931LC	7,996
	1610	110	1824RC	1821RC	1824LC	1821LC	387
	2012	125	1844RC	1841RC	1844LC	1841LC	626
	2516	140	1864RC	1861RC	1864LC	1861LC	893
	3220	170	1884RC	1881RC	1884LC	1881LC	1,225
	4025	200	1904RC	1901RC	1904LC	1901LC	1,966
122 - POINTED TURNING TOOLS	NEUTRAL (NH)						
	1010	90	0805SC	0801SC			361
	1212	100	0815SC	0811SC			441
	1616	110	0835SC	0831SC			487
	2020	125	0855SC	0851SC			666
	2525	140	0875SC	0871SC			948
	3232	170	0895SC	0891SC			2,352
	4040	200	0902SC	0903SC			4,316
	5050	240	0925SC	0926SC			4,706
	1610	110	0825SC	0821SC			481
	2012	125	0845SC	0841SC			510
	2516	140	0865SC	0861SC			666
	3220	170	0885SC	0881SC			992
	4025	200	0905SC	0901SC			1,658
	5032	240	0906SC	0907SC			3,479
140 (60°) BORING TOOLS (SQUARE)			RIGHT HAND (RH)		LEFT HAND (LH)		
	0808	24	3604RC	3601RC	3604LC	3601LC	415
	1010 & 3/8"	50	3614RC	3611RC	3614LC	3611LC	415
	1212 & 1/2"	60	3624RC	3621RC	3624LC	3621LC	476
	1616 & 5/8"	90	3634RC	3631RC	3634LC	3631LC	666
	2020 & 3/4"	120	3644RC	3641RC	3644LC	3641LC	1,058
	2525 & 1"	175	3654RC	3651RC	3654LC	3651LC	1,395
140 (60°) BORING TOOLS (ROUND)							
	Ø8	24	3504RC	3501RC	3504LC	3501LC	361
	Ø10 & 3/8"	50	3514RC	3511RC	3514LC	3511LC	361
	Ø12 & 1/2"	60	3524RC	3521RC	3524LC	3521LC	422
	Ø16 & 5/8"	90	3534RC	3531RC	3534LC	3531LC	548
	Ø20 & 3/4"	120	3544RC	3541RC	3544LC	3541LC	982
	Ø25 & 1"	175	3554RC	3551RC	3554LC	3551LC	1,274

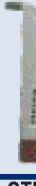
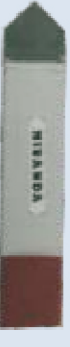
141 (90°) BORING TOOLS (SQUARE) 	SHANK SIZE H X B (mm)	L (mm)	RIGHT HAND (RH)		LEFT HAND (LH)		PRICE RS./ PIECE
			ORDER CODE - MIR100				
			P30	K20	P30	K20	
	0808	24	4104RC	4101RC	4104LC	4101LC	415
	1010 & 3/8"	50	4114RC	4111RC	4114LC	4111LC	415
	1212 & 1/2"	60	4124RC	4121RC	4124LC	4121LC	476
	1616 & 5/8"	90	4134RC	4131RC	4134LC	4131LC	666
	2020 & 3/4"	120	4144RC	4141RC	4144LC	4141LC	1,058
	2525 & 1"	175	4154RC	4151RC	4154LC	4151LC	1,395
141 (90°) BORING TOOLS (ROUND) 	Ø08	24	4004RC	4001RC	4004LC	4001LC	361
	Ø10 & 3/8"	50	4014RC	4011RC	4014LC	4011LC	361
	Ø12 & 1/2"	60	4024RC	4021RC	4024LC	4021LC	422
	Ø16 & 5/8"	90	4034RC	4031RC	4034LC	4031LC	548
	Ø20 & 3/4"	120	4044RC	4041RC	4044LC	4041LC	982
	Ø25 & 1"	175	4054RC	4051RC	4054LC	4051LC	1,274
142 (45°) BORING TOOLS (SQUARE) 	0808	24	4604RC	4601RC	4604LC	4601LC	415
	1010 & 3/8"	50	4614RC	4611RC	4614LC	4611LC	415
	1212 & 1/2"	60	4624RC	4621RC	4624LC	4621LC	476
	1616 & 5/8"	90	4634RC	4631RC	4634LC	4631LC	666
	2020 & 3/4"	120	4644RC	4641RC	4644LC	4641LC	1,058
	2525 & 1"	175	4654RC	4651RC	4654LC	4651LC	1,395
142 (45°) BORING TOOLS (ROUND) 	Ø08	24	4504RC	4501RC	4504LC	4501LC	361
	Ø10 & 3/8"	50	4514RC	4511RC	4514LC	4511LC	361
	Ø12 & 1/2"	60	4524RC	4521RC	4524LC	4521LC	422
	Ø16 & 5/8"	90	4534RC	4531RC	4534LC	4531LC	548
	Ø20 & 3/4"	120	4544RC	4541RC	4544LC	4541LC	982
	Ø25 & 1"	175	4554RC	4551RC	4554LC	4551LC	1,274
156 - CRANKED INTERNAL RECESSING TOOLS 	1010	90	5404RC	5401RC	5404LC	5401LC	681
	1212	100	5414RC	5411RC	5414LC	5411LC	777
	1616	110	5424RC	5421RC	5424LC	5421LC	870
	2020	125	5434RC	5431RC	5434LC	5431LC	1,124
	2525	140	5444RC	5441RC	5444LC	5441LC	1,539
	3232	170	5454RC	5451RC	5454LC	5451LC	2,190
	4040	315	5464RC	5461RC	5464LC	5461LC	3,633
163 - STRAIGHT TURNING & GROOVING TOOLS 	NEUTRAL (NH)						
	1010	90	5704SC	5701SC			441
	1212	100	5714SC	5711SC			503
	1616	110	5734SC	5731SC			760
	2020	125	5754SC	5751SC			1,107
	2525	140	5774SC	5771SC			1,849
	3232	170	5794SC	5791SC			4,029
	4040	200	5798SC	5762SC			7,734
	1610	110	5724SC	5721SC			431
	2012	125	5744SC	5741SC			550
	2516	140	5764SC	5761SC			833
	3220	170	5784SC	5781SC			1,365

165 - STRAIGHT THREADING TOOLS (60°)	SHANK SIZE H X B (mm)	L (mm)	RIGHT HAND (RH)		LEFT HAND (LH)		PRICE RS./ PIECE
			ORDER CODE - MIR100				
			P30	K20	P30	K20	
	1010	90	6002RC	6001RC	6002LC	6001LC	476
	1212	100	6012RC	6011RC	6012LC	6011LC	504
	1616	110	6044RC	6031RC	6044LC	6031LC	656
	2020	125	6054RC	6051RC	6054LC	6051LC	893
	2525	140	6074RC	6071RC	6074LC	6071LC	1,328
	3232	170	6094RC	6091RC	6094LC	6091LC	1,757
166 - INTERNAL THREADING TOOLS (60°)	1010	90	6204RC	6201RC	6204LC	6201LC	787
	1212	100	6214RC	6211RC	6214LC	6211LC	889
	1616	110	6224RC	6221RC	6224LC	6221LC	965
	2020	125	6234RC	6231RC	6234LC	6231LC	1,184
	2525	140	6256RC	6241RC	6256LC	6241LC	1,550
	3232	170	6254RC	6251RC	6254LC	6251LC	2,338
IND-2-EXTERNAL THREADING TOOLS	1010	90	0905RC	0901RC	0905LC	0901LC	559
	1212	100	0915RC	0911RC	0915LC	0911LC	660
	1616	110	0935RC	0931RC	0935LC	0931LC	702
	2020	125	0955RC	9101RC	0955LC	9101LC	779
	2525	140	0975RC	0971RC	0975LC	0971LC	1,302
THREADING TOOLS WITH "V" PROFILE	NEUTRAL (NH)						
	166 - 11	140	6264RC	6261RC			719
	166 - 12	160	6274RC	6271RC			878
	166 - 13	180	6284RC	0114RC			1,225
	166 - 14	200	6294RC	6292RC			1,709

Indian Standard Application of Carbides for Machining, Ranges of application and Colour Code Selection Guideline for Tip Grade

Identification Colour	Designation	Material to be Machined
	P20	Steel, steel casting, Malleable cast iron forming long chips Machining Conditions Turning & Milling-Medium cutting speed and medium chip section, Planing with small chip section
	P30	Steel, steel casting, Malleable cast iron forming long chips Machining Conditions Turning, Milling & Planning-Medium or low cutting speed, medium or large chip section and machining under unfavourable conditions such as heat erogenous materials, changing hardness or chip section, intermittent turning or subject to vibrations.
	P40	Steel, steel casting with sand inclusions or shrinkage cavities Machining Conditions Turning, Planning & Shapping-Low cutting speed, large chip section with possibility of using large rake angle for machining under unfavourable conditions, such as heat erogenous materials, changing hardness or chip sections, intermillent turning or subject to vibrations; and work on automatic machines.
	K10	Grey cast iron of hardness more than 220 HB, Malleable cast iron forming short chips, Tempered steel, Aluminium alloys containing silicon, copper alloys, plastics, glass, hard rubber, hard carboard, porcelain, stone. Machining Conditions Turning, Milling, Boring, Scraping
	K20	Grey cast iron of hardness up to 220 HB, Non-ferrous metals, such as Copper, Brass, . Aluminium, Laminated wood of abrasive type Machining Conditions Turning, Milling, planning, requiring high toughness.



MIRANDA TOOLS
Premium quality cutting tools

DORMER PRAMET

**MIRANDA
Maxx**

TUNGSTEN CARBIDE ROTARY BURRS



PRODUCT RANGE

Types : Cylindrical & with Radius Flame, Rim & Inverted Cone
Tree shape - Radius / Pointed end
Cone shape - Radius / Pointed end

Range : Diameter 3.0 mm to 25.0 mm, Shank 3.0 mm, 6.0 mm & 8.0 mm
Single cut, Double cut, Diamond cut & Aluma cut

APPLICATIONS

- Cast Iron
- Mild Steel
- Stainless Steel
- Forged Steel
- Titanium
- Aluminium

INDUSTRIES

- Foundry, Casting & Fabrication
- Marine & Shipbuilding
- Automobile, Heavy Engineering
- Tubes & Pipes
- Aerospace & Defense
- Gear Manufacturing

www.mirandatools.net

www.dormerpramet.com

TUNGSTEN CARBIDE ROTARY BURRS

SHAPE	MIRANDA CODE	DESCRIPTION	PRICE RS./ PIECE			
			ORDER CODE	STANDARD PRICE	ORDER CODE	TIN COATED PRICE
		HEAD DIA X HEAD LENGTH	MIETCRBFU		MIRTCRBFU	
X OAL LENGTH X SHANK DIA						
 CONICAL	MAM1	3MM X 11MM X 38MM X 3SHK	1011AS	445	1011AS	490
	MAM2	6MM X 11MM X 38MM X 3SHK	1012BS	583	1012BS	643
	AM1	6MM X 19MM X 60MM X 6SHK	1010AS	691	1010AS	760
	AM2	10MM X 20MM X 70MM X 6SHK	1020BS	691	1020BS	760
	AM3	12MM X 25MM X 75MM X 6SHK	1030CS	949	1030CS	1044
	AM4	10MM X 12MM X 60MM X 6SHK	1040DS	720	1040DS	790
	AM5	16MM X 13MM X 63MM X 6SHK	1050ES	1037	1050ES	1167
	AM6	16MM X 16MM X 66MM X 6SHK	1060FS	1037	1060FS	1167
 CYLINDRICAL RADIUS END	MBM1	3MM X 16MM X 38MM X 3SHK	2011AS	445	2011AS	490
	MBM2	6MM X 13MM X 38MM X 3SHK	2012BS	583	2012BS	643
	BM1	6MM X 20MM X 50MM X 6SHK	2010AS	699	2010AS	767
	BM2	8MM X 20MM X 70MM X 6SHK	2020BS	675	2020BS	744
	BM3	10MM X 20MM X 70MM X 6SHK	2030CS	844	2030CS	928
	BM4	12MM X 20MM X 70MM X 6SHK	2040DS	1088	2040DS	1220
	BM5	16MM X 25MM X 75MM X 6SHK	2050ES	1664	2050ES	1863
	BM6	12MM X 25MM X 75MM X 6SHK	2060FS	1511	2060FS	1695
 CYLINDRICAL	MCM1	3MM X 16MM X 38MM X 3SHK	3011AS	445	3011AS	490
	MCM2	6MM X 6MM X 38MM X 3SHK	3012BS	500	3012BS	552
	MCM3	6MM X 13MM X 38MM X 3SHK	3013CS	583	3013CS	643
	CM1	4MM X 15MM X 50MM X 6SHK	3010AS	583	3010AS	643
	CM2	6MM X 20MM X 60MM X 6SHK	3020BS	669	3020BS	737
	CM3	8MM X 20MM X 70MM X 6SHK	3030CS	760	3030CS	836
	CM4	10MM X 20MM X 70MM X 6SHK	3040DS	836	3040DS	920
	CM5	12MM X 20MM X 70MM X 6SHK	3050ES	1051	3050ES	1174
	CM6	16MM X 25MM X 75MM X 6SHK	3060FS	1685	3060FS	1885
	CM7	12MM X 16MM X 65MM X 6SHK	3070GS	1026	3070GS	1149
	CM8	12MM X 25MM X 75MM X 6SHK	3080HS	1664	3080HS	1863
 FLAME	FM1	6MM X 15MM X 50MM X 6SHK	4010AS	669	4010AS	737
	FM2	8MM X 20MM X 70MM X 6SHK	4020BS	691	4020BS	760
	FM3	10MM X 25MM X 65MM X 6SHK	4030CS	1364	4030CS	1526
	FM4	12MM X 32MM X 82MM X 6SHK	4040DS	1638	4040DS	1849
 CONE RADIUS	MKM1	3MM X 8MM X 38MM X 3SHK	5011AS	445	5011AS	490
	MKM2	6MM X 12MM X 38MM X 3SHK	5012BS	583	5012BS	643
	KM1	10MM X 20MM X 65MM X 6SHK	5010AS	654	5010AS	720
	KM2	12MM X 20MM X 70MM X 6SHK	5020BS	1088	5020BS	1220
	KM3	16MM X 33MM X 75MM X 6SHK	5030CS	1503	5030CS	1679

SHAPE	MIRANDA CODE	DESCRIPTION	PRICE RS./ PIECE			
			ORDER CODE	STANDARD PRICE	ORDER CODE	TIN COATED PRICE
		HEAD DIA X HEAD LENGTH	MIETCRBFU		MIRTCRBFU	
 OVAL	MOM1	3MM X 8MM X 38MM X 3SHK	MOM1S0814	445	MOM1S0814	490
	MOM2	6MM X 10MM X 38MM X 3SHK	MOM2S0610	583	MOM2S0610	643
	OM1	8MM X 14MM X 60MM X 6SHK	OM10S0814	744	OM10S0814	821
	OM2	12MM X 20MM X 70MM X 6SHK	OM20S1220	1088	OM20S1220	1220
	OM3	16MM X 25MM X 75MM X 6SHK	OM30S1625	1679	OM30S1625	1879
	OM4	6MM X 10MM X 60MM X 6SHK	OM40S0610	744	OM40S0610	821
 RIM	RM1	10MM X 2MM X 50MM X 6SHK	RM10S1002	654	RM10S1002	720
	RM2	20MM X 6MM X 60MM X 6SHK	RM20S2006	1226	RM20S2006	1350
	RM3	12MM X 10MM X 60MM X 6SHK	RM30S1210	1088	RM30S1210	1197
 BALL	MSM1	4MM X 3MM X 38MM X 3SHK	MSM1S0403	516	MSM1S0403	567
	MSM2	5MM X 4MM X 38MM X 3SHK	MSM2S0504	538	MSM2S0504	592
	SM1	6MM X 5MM X 50MM X 6SHK	SM10S0605	643	SM10S0605	705
	SM2	8MM X 7MM X 50MM X 6SHK	SM20S0807	676	SM20S0807	744
	SM3	10MM X 9MM X 60MM X 6SHK	SM30S1009	676	SM30S1009	744
	SM4	12MM X 11MM X 60MM X 6SHK	SM40S1211	849	SM40S1211	933
	SM5	16MM X 14MM X 65MM X 6SHK	SM50S1614	1149	SM50S1614	1289
 TREE POINTED END	MTM1	3MM X 13MM X 38MM X 3SHK	MTM1S0313	445	MTM1S0313	490
	MTM2	3MM X 16MM X 38MM X 3SHK	MTM2S0316	445	MTM2S0316	490
	MTM3	6MM X 13MM X 38MM X 3SHK	MTM3S0613	583	MTM3S0613	643
	TM1	6MM X 20MM X 70MM X 6SHK	TM10S0620	705	TM10S0620	774
	TM2	10MM X 20MM X 70MM X 6SHK	TM20S1020	844	TM20S1020	928
	TM3	12MM X 25MM X 75MM X 6SHK	TM30S1225	1011	TM30S1225	1113
	TM4	16MM X 30MM X 80MM X 6SHK	TM40S1630	1503	TM40S1630	1679
 TREE RADIUS END	TBM1	6MM X 20MM X 70MM X 6SHK	TBM1S0620	705	TBM1S0620	774
	TBM2	10MM X 20MM X 70MM X 6SHK	TBM2S1020	844	TBM2S1020	928
	TBM3	12MM X 25MM X 75MM X 6SHK	TBM3S1225	1066	TBM3S1225	1197
 INVERTED CONE	MIM1	3MM X 8MM X 38MM X 3SHK	MIM1S0308	445	MIM1S0308	490
	MIM2	6MM X 8MM X 38MM X 3SHK	MIM2S0608	500	MIM2S0608	552
SET OF 5 PIECES		AM3, BM4, CM5, TM3, SM4	SET0S1200	4859	SET0S1200	5383



MIRANDA TOOLS
Premium quality cutting tools

DORMER PRAMET

SOLID CARBIDE TOOLS

MIRANDA
Maxx



**SOLID CARBIDE TOOLS
END MILLS**



SCCEM 4 FLUTE - TiAlN coated				
Dia	SH.DIA	FL	OAL	PRICE RS./PIECE
1.0	3.0	3	38	937
1.5	3.0	6	38	937
2.0	3.0	9	38	937
2.5	3.0	9	38	937
3.0	3.0	12	38	882
3.5	4.0	14	50	1,159
4.0	4.0	14	50	1,159
4.5	5.0	16	50	1,455
5.0	5.0	20	50	1,455
5.5	6.0	20	60	1,520
6.0	6.0	20	60	1,520
8.0	8.0	20	60	1,682
10.0	10.0	25	75	3,200
12.0	12.0	25	75	3,712
14.0	14.0	25	75	6,518
16.0	16.0	32	89	7,044
20.0	20.0	38	100	14,969

SCBALL NOSE-EM 4 FLUTE - TiAlN coated				
Dia	SH.DIA	FL	OAL	PRICE RS./PIECE
1.0	3.0	3	38	1,183
1.5	3.0	5	38	1,183
2.0	3.0	7	38	1,183
2.5	3.0	7	38	1,183
3.0	3.0	9	38	1,066
4.0	4.0	14	50	1,390
5.0	5.0	16	50	1,751
6.0	6.0	20	60	1,826
8.0	8.0	20	60	2,058
10.0	10.0	25	75	3,836
12.0	12.0	25	75	4,460
16.0	16.0	32	89	8,468
20.0	20.0	38	102	17,964



LONG LENGTH 4 FLUTE				PRICE RS./PIECE
Dia	SH.DIA	FL	OAL	PRICE RS./PIECE
3	3	20	60	1,684
4	4	20	60	1,900
5	5	25	75	2,117
6	6	30	75	2,209
8	8	40	100	2,459
10	10	40	100	3,877
10	10	75	150	8,851
12	12	50	100	5,557
12	12	75	150	10,857
16	16	75	150	16,288
20	20	75	150	27,092

SCNB - LONG LENGTH 4 FLUTE				PRICE RS./PIECE
Dia	SH.DIA	FL	OAL	PRICE RS./PIECE
3	3	20	60	2,019
4	4	20	60	2,282
5	5	25	75	2,538
6	6	30	75	2,654
8	8	40	100	2,920
10	10	40	100	4,654
10	10	75	150	10,623
12	12	50	100	6,660
12	12	75	150	13,030
16	16	75	150	19,548
20	20	75	150	32,512

SOLID CARBIDE TOOLS DRILL



Solid Carbide Jobber Drill -TiAlN Coated				
Dia	SH.DIA	FL	OAL	PRICE RS./ PIECE
1.0	1.0	12	32	806
1.5	1.5	18	40	865
2.0	2.0	24	49	989
2.5	2.5	30	57	989
3.0	3.0	33	61	1,107
3.5	3.5	39	70	1,205
4.0	4.0	43	75	1,483
4.5	4.5	47	80	1,588
5.0	5.0	52	86	1,819
5.5	5.5	57	93	2,105
6.0	6.0	57	93	2,190
6.5	6.5	63	101	2,466
7.0	7.0	69	109	2,700
7.5	7.5	69	109	2,947
8.0	8.0	75	117	3,323
8.5	8.5	75	117	3,641
9.0	9.0	81	125	4,131
9.5	9.5	81	125	4,716
10.0	10.0	87	133	5,413
10.5	10.5	87	133	6,050
11.0	11.0	94	142	7,200
12.0	12.0	101	151	8,231
13.0	13.0	101	151	10,286
14.0	14.0	108	160	12,841
16.0	16.0	120	178	19,065

Solid Carbide Stub Drill-TiAlN Coated				
Dia	SH.DIA	FL	OAL	PRICE RS./ PIECE
1.0	1.0	6	26	740
1.5	1.5	9	32	795
2.0	2.0	12	38	909
2.5	2.5	14	43	909
3.0	3.0	16	46	1,017
3.5	3.5	20	52	1,049
4.0	4.0	22	55	1,291
4.5	4.5	24	58	1,381
5.0	5.0	26	62	1,583
5.5	5.5	28	66	1,832
6.0	6.0	28	66	1,906
6.5	6.5	31	70	2,047
7.0	7.0	34	74	2,241
7.5	7.5	34	74	2,446
8.0	8.0	37	79	2,758
8.5	8.5	37	79	3,022
9.0	9.0	40	84	3,237
9.5	9.5	40	84	3,696
10.0	10.0	43	89	4,241
10.5	10.5	43	89	4,740
11.0	11.0	47	95	6,225
12.0	12.0	51	102	6,225
13.0	13.0	51	103	9,313
14.0	14.0	54	107	9,313
16.0	16.0	58	115	13,835

- END MILL FOR 60HRC ON REQUEST
- END MILL WITH CORNER RADIUS & SPECIAL ON REQUEST.
- PRICES ARE SUBJECT TO REVISION WITHOUT ANY NOTICE.

SUGGESTED SPEED AND FEED DATA FOR SOLID CARBIDE ENDMILLS

Application : Slotting / Key way machining

Material HRc Diameter	Carbon steel , Alloy Steel < HRc 28		Carbon steel , Alloy Steel HRc 28 - HRc 45		Stainless Steel and Super alloys		Cast Iron	
	RPM	feed/tooth	RPM	feed/tooth	RPM	feed/tooth	RPM	feed/tooth
2	6369	0.03	6369	0.024	6369	0.02	6369	0.044
3	4777	0.045	4777	0.036	4777	0.03	4777	0.066
4	3981	0.06	3981	0.048	3981	0.04	3981	0.088
5	3185	0.075	3185	0.06	3185	0.05	3185	0.11
6	2654	0.09	2654	0.072	2654	0.06	2654	0.132
8	1990	0.12	1990	0.096	1990	0.08	1990	0.176
10	1911	0.15	1911	0.12	1911	0.1	1911	0.22
12	1592	0.18	1592	0.144	1592	0.12	1592	0.264
14	1365	0.21	1365	0.168	1365	0.14	1365	0.308
16	1393	0.24	1393	0.192	1393	0.16	1393	0.352
18	1238	0.27	1238	0.216	1238	0.18	1238	0.396
20	1115	0.3	1115	0.24	1115	0.2	1115	0.44

- Reduce feed rate by around 30% in case of long types
- Increase speed and feed rate by around 25% in case of coated endmills

Application : End milling

Material HRc Diameter	Carbon steel , Alloy Steel < HRc 28		Carbon steel , Alloy Steel HRc 28 - HRc 45		Stainless Steel and Super alloys		Grey Cast Iron	
	RPM	feed/tooth	RPM	feed/tooth	RPM	feed/tooth	RPM	feed/tooth
2	6369	0.04	6369	0.03	6369	0.024	6369	0.06
3	4777	0.06	4777	0.045	4777	0.036	4777	0.09
4	3981	0.08	3981	0.06	3981	0.048	3981	0.12
5	3185	0.1	3185	0.075	3185	0.06	3185	0.15
6	2654	0.12	2654	0.09	2654	0.072	2654	0.18
8	1990	0.16	1990	0.12	1990	0.096	1990	0.24
10	1911	0.2	1911	0.15	1911	0.12	1911	0.3
12	1592	0.24	1592	0.18	1592	0.144	1592	0.36
14	1365	0.28	1365	0.21	1365	0.168	1365	0.42
16	1393	0.32	1393	0.24	1393	0.192	1393	0.48
18	1238	0.36	1238	0.27	1238	0.216	1238	0.54
20	1115	0.4	1115	0.3	1115	0.24	1115	0.6

SUGGESTED SPEED AND FEED DATA FOR SOLID CARBIDE DRILLS

Application : Drilling

Material HRc Diameter	Carbon steel , Alloy Steel < HRc 28		Carbon steel , Alloy Steel HRc 28 - HRc 45		Stainless Steel and Super alloys		Cast Iron	
	RPM	mm/rev	RPM	mm/rev	RPM	mm/rev	RPM	mm/rev
2	5100	0.04	5100	0.03	4900	0.02	5100	0.06
3	4246	0.045	4246	0.036	4246	0.03	4246	0.066
4	3583	0.06	3583	0.048	3583	0.04	3583	0.088
5	2866	0.075	2866	0.06	2866	0.05	2866	0.11
6	2389	0.09	2389	0.072	2389	0.06	2389	0.132
8	1990	0.12	1990	0.096	1990	0.08	1990	0.176
10	1592	0.15	1592	0.12	1592	0.10	1592	0.22
12	1327	0.18	1327	0.144	1327	0.12	1327	0.264
14	1251	0.21	1251	0.168	1251	0.14	1251	0.308
16	1194	0.24	1194	0.192	1194	0.16	1194	0.352
18	1062	0.27	1062	0.216	1062	0.18	1062	0.396
20	1115	0.3	1115	0.24	1115	0.2	1115	0.44

- Increase speed and feed rate by around 25% in case of coated endmills
- Reduce feed rate by around 30% in case of long types
- Increase speed and feed rate by around 25% in case of coated Drills

Technical Formulae

Cutting speed.	=	$\pi \times \text{Dia of Tool} \times \text{RPM} / 1000$
Feed in mm per revolution.	=	feed in mm per tooth X no. of flutes
Feed in mm per min.	=	RPM X feed in mm per revolution.
Cutting time.	=	Cutting length / feed in mm per min

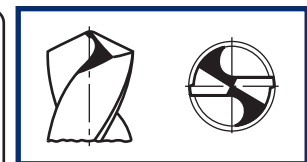

Split Point Geometry

WE MAKE THE SHIFT

ADVANCING THE WORLD
THROUGH ENGINEERING

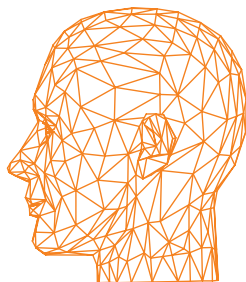

CUSTOMER FOCUS

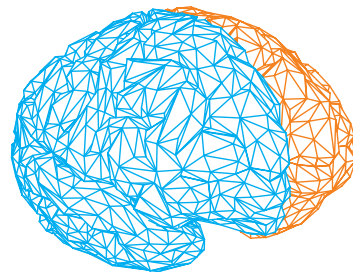

INNOVATION

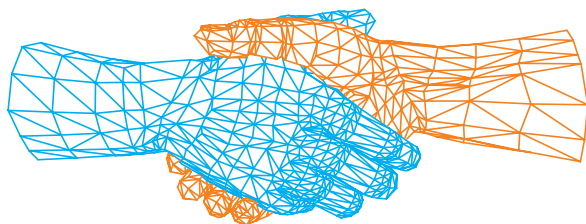

FAIR PLAY



PASSION TO WIN



MIRANDA TOOLS

Authorised Dealer



Gokul Traders

Address: 983, Raviwar Peth, Laxmi Road, Pune-411 002

Phone: +91-20-24450644, +91-20-24483758, +91-7972- 969-901

Email ID: mail@gokultraders.com