

Innovation • Precision • Excellence

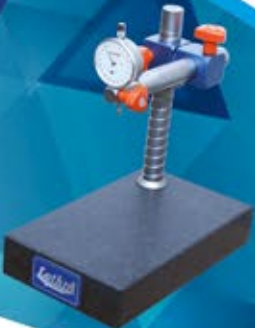

Luthra

Granite Comparator Stands

Luthra
QUALITY



Granite Comparator Stands



Dial comparator stands are designed for comparison measurement of size using a dial indicator, as it is most reliable instrument. We manufacture one of the finest quality of granite and cast iron comparator stands which are widely known for its quality and workmanship.

We have well equipped NABL accredited calibration laboratory.

- Granite comparator stands are made from selected black granite.
- Precision lapped for feather finish and fine accuracy.
- Corrosion resistant and non magnetic base.
- Heavy duty vertical column and gauging bracket.
- Accepts all electronic and standard gauges.
- Calibration certificate is provided with each comparator stand.

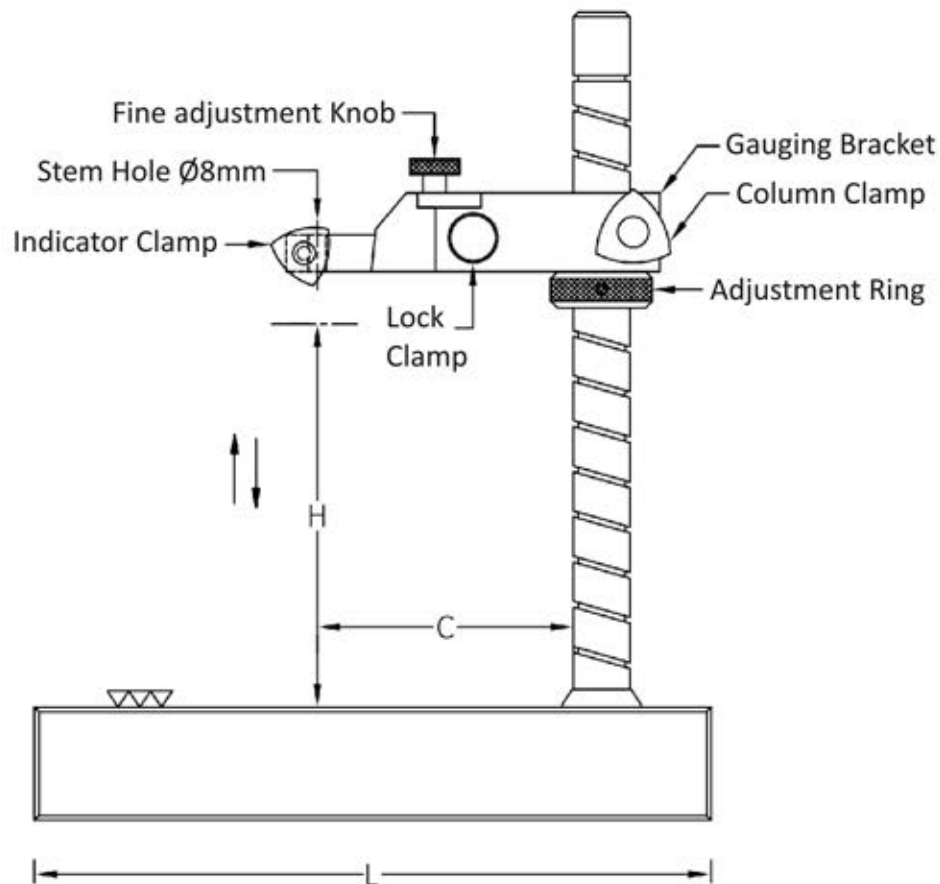

SIDE VIEW

Fine Adjustment Model

- Granite base, Gauging bracket and Vertical column can be customized

Granite Comparator Stands



LGS - 1



LGS - 2



LGS - 3

Model	Base Size mm	Base Type	Flatness Microns μm	Gauging Bracket	Measuring Height (H) mm	Cross Arm (C) mm	Coulnn Dia mm	Net Weight Kgs
LGS-1	150 x 100	Plain	3	Centre	100	55	25	4.00
LGS-2	150 x 100	Plain	3	Fine Adjustment	100	55	25	4.00
LGS-3	150 x 100	Serrated	3	Centre	100	55	25	4.00



LGS - 4



LGS - 5



LGS - 6



LGS - 7

Model	Base Size mm	Base Type	Flatness Microns μm	Gauging Bracket	Measuring Height (H) mm	Cross Arm (C) mm	Couln Dia mm	Net Weight Kgs
LGS-4	150 x 100	Serrated	3	Fine Adjustment	100	55	25	4.00
LGS-5	150 x 150	Plain	3	Centre	100	55	25	4.00
LGS-6	150 x 150	Plain	3	Fine Adjustment	100	55	25	4.00
LGS-7	150 x 150	Serrated	3	Fine Adjustment	100	55	25	4.00

Granite Comparator Stands



LGS - 8



LGS - 9



LGS - 10

Model	Base Size mm	Base Type	Flatness Microns μm	Gauging Bracket	Measuring Height (H) mm	Cross Arm (C) mm	Coulnn Dia mm	Net Weight Kgs
LGS-8	250 x 150	Plain	3	Centre	150	85	25	8.00
LGS-9	250 x 150	Plain	3	Fine Adjustment	150	85	25	8.50
LGS-10	250 x 150	Plain	3	Eccentric	150	100	25	9.00



LGS - 11



LGS - 12



LGS - 13

Model	Base Size mm	Base Type	Flatness Microns μm	Gauging Bracket	Measuring Height (H) mm	Cross Arm (C) mm	Coulnn Dia mm	Net Weight Kgs
LGS-11	250 x 150	Serrated	3	Centre	150	85	25	8.00
LGS-12	250 x 150	Serrated	3	Fine Adjustment	150	85	25	8.50
LGS-13	250 x 150	Serrated	3	Eccentric	150	100	25	9.00

Granite Comparator Stands



LGS - 14



LGS - 15



LGS - 16

Model	Base Size mm	Base Type	Flatness Microns μm	Gauging Bracket	Measuring Height (H) mm	Cross Arm (C) mm	Column Dia mm	Net Weight Kgs
LGS-14	300 x 200	Plain	3.5	Centre	200	115	28	12.00
LGS-15	300 x 200	Plain	3.5	Fine Adjustment	200	110	28	12.50
LGS-16	300 x 200	Plain	3.5	Eccentric	200	200	28	13.00



LGS - 17



LGS - 18



LGS - 19

Model	Base Size mm	Base Type	Flatness Microns μm	Gauging Bracket	Measuring Height (H) mm	Cross Arm (C) mm	Couln Dia mm	Net Weight Kgs
LGS-17	300 x 200	Serrated	3.50	Centre	200	115	28	12.00
LGS-18	300 x 200	Serrated	3.50	Fine Adjustment	200	110	28	12.50
LGS-19	300 x 200	Serrated	3.50	Eccentric	200	200	28	13.00

Granite Comparator Stands



LGS - 20



LGS - 21



LGS - 22

Model	Base Size mm	Base Type	Flatness Microns μm	Gauging Bracket	Measuring Height (H) mm	Cross Arm (C) mm	Coulmn Dia mm	Net Weight Kgs
LGS-20	300 x 300	Plain	4	Centre	250	115	28	17.50
LGS-21	300 x 300	Plain	4	Fine Adjustment	250	110	28	18.00
LGS-22	300 x 300	Plain	4	Eccentric	250	200	28	18.50



LGS - 23



LGS - 24



LGS - 25



LGS - 26

Model	Base Size mm	Base Type	Flatness Microns μm	Gauging Bracket	Measuring Height (H) mm	Cross Arm (C) mm	Coulmn Dia mm	Net Weight Kgs
LGS-23	300 x 300	Serrated	4.0	Centre	250	115	28	17.5
LGS-24	300 x 300	Serrated	4.0	Fine Adjustment	250	110	28	18.0
LGS-25	300 x 300	Serrated	4.0	Eccentric	250	200	28	18.5
LGS-26	300 x 300	Plain	4.0	Double Eccentric	250	200	28	22.0

Granite Comparator Stands



LGS - 27



LGS - 28



LGS - 29



LGS - 30

Model	Base Size mm	Base Type	Flatness Microns μm	Gauging Bracket	Measuring Height (H) mm	Cross Arm (C) mm	Coulnn Dia mm	Net Weight Kgs
LGS-27	300 x 300	Plain	4.0	Universal Arm	250	200	28	16.00
LGS-28	400 x 400	Plain	4.5	Centre	300	150	35	35.00
LGS-29	400 x 400	Plain	4.5	Fine Adjustment	300	150	35	35.00
LGS-30	400 x 400	Plain	4.5	Eccentric	300	250	35	35.00

Cast Iron Comparator Stands

Luthra
INDIA



● Dial indicator is not included with each model

Cast Iron Comparator Stands



Luthra cast iron comparator stands are made from selected quality close grain graded casting, which is further processed to finest accuracy, our vast experience makes our product most versatile and easy to use.

We have well equipped NABL accredited calibration laboratory.

- Cast iron anvil is of FG 220 grade ,having hardness within 180 – 220 BHN
- Cast iron anvil is precision ground
- Hardened anvil is made of high quality alloy steel, stablized and precision ground.
- Alloy steel anvil hardness within 55-58 HRC
- Heavy duty vertical coulumn and gauging bracket.
- Accepts all electronic and standard gauges.
- Calibration certificate is provided with each comparator stand

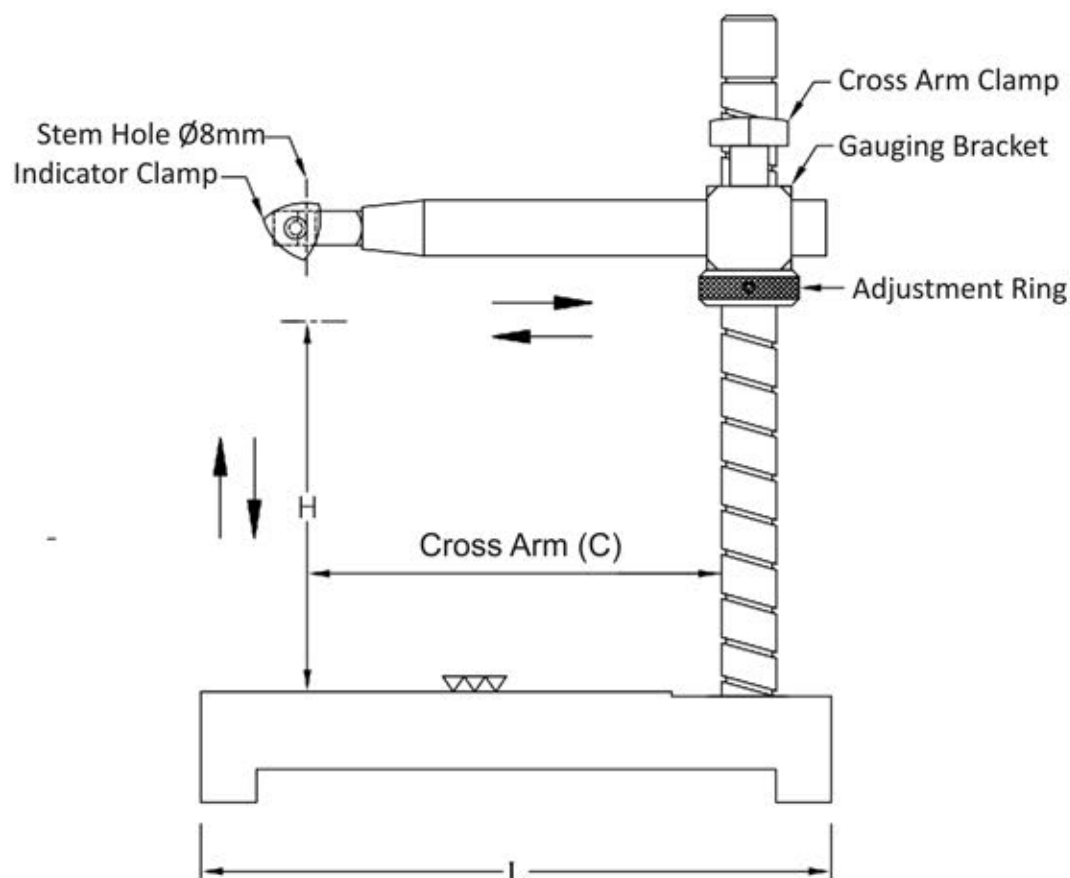

SIDE VIEW

Eccentric Model

- Anvil size, Gauging bracket and Vertical column can be customized



LCS - 1



LCS - 2



LCS - 3

Model	Anvil Size	Anvil Type	Flatness Microns μm	Gauging Bracket	Measuring Height (H) mm	Cross Arm (C) mm	Column Dia ϕ mm	Net Weight Kgs
LCS-1	DIA 60	Hardened	3.00	Centre	100	55	25	3.50
LCS-2	DIA 60	Hardened Serrated	3.00	Fine Adjustment	100	55	25	4.00
LCS-3	70 X 70	Hardened	3.00	Centre	100	55	25	3.50

Cast Iron Comparator Stands

Luthra



LCS - 4



LCS - 5



LCS - 6

Model	Anvil Size mm	Anvil Type	Flatness Microns μ m	Gauging Bracket	Measuring Height (H) mm	Cross Arm (C) mm	Column Dia ϕ mm	Net Weight Kgs
LCS-4	70 x 70	Hardened Serrated	3.00	Fine Adjustment	100	55	25	4.00
LCS-5	125 x 100	Hardened	5.00	Centre	150	85	25	6.50
LCS-6	125 x 100	Hardened	5.00	Fine Adjustment	150	85	25	7.00



LCS - 7



LCS - 8



LCS - 9

Model	Anvil Size mm	Anvil Type	Flatness Microns μm	Gauging Bracket	Measuring Height (H) mm	Cross Arm (C) mm	Column Dia \varnothing (mm)	Net Weight Kgs
LCS-7	125 x 100	Hardened Serrated	5.00	Fine Adjustment	150	85	25	7.00
LCS-8	125 x 100	Hardened Serrated	5.00	Eccentric	150	100	25	7.50
LCS-9	150 x 150	Cast Iron	5.00	Centre	150	85	25	8.00

Cast Iron Comparator Stands

Luthra



LCS - 10



LCS - 11



LCS - 12

Model	Anvil Size mm	Anvil Type	Flatness Microns μ m	Gauging Bracket	Measuring Height (H) mm	Cross Arm (C) mm	Column Dia ϕ mm	Net Weight Kgs
LCS-10	150 x 150	Cast Iron	5.00	Fine Adjustment	150	85	25	8.50
LCS-11	150 x 150	Hardened Serrated	5.00	Fine Adjustment	150	85	25	9.50
LCS-12	225 x 150	Cast Iron	6.00	Centre	200	115	28	9.50



LCS - 13



LCS - 14



LCS - 15

Model	Anvil Size mm	Anvil Type	Flatness Microns μm	Gauging Bracket	Measuring Height (H) mm	Cross Arm (C) mm	Column Dia ϕ mm	Net Weight Kgs
LCS-13	225 x 150	Cast Iron	6.00	Eccentric	200	200	28	11.00
LCS-14	225 x 150	Cast Iron Serrated	6.00	Fine Adjustment	200	110	28	10.00
LCS-15	225 x 150	Hardened	6.00	Centre	200	115	28	12.00

Cast Iron Comparator Stands

Luthra



LCS - 16



LCS - 17



LCS - 18

Model	Anvil Size mm	Anvil Type	Flatness Microns μm	Gauging Bracket	Measuring Height (H) mm	Cross Arm (C) mm	Column Dia ϕ mm	Net Weight Kgs
LCS-16	225 x 150	Hardened	6.00	Fine Adjustment	200	110	28	12.50
LCS-17	225 x 150	Hardened Serrated	6.00	Eccentric	200	200	28	13.00
LCS-18	200 x 200	Cast Iron Serrated	6.50	Centre	200	115	28	13.50



LCS - 19



LCS - 20



LCS - 21

Model	Anvil Size mm	Anvil Type	Flatness Microns μm	Gauging Bracket	Measuring Height (H) mm	Cross Arm (C) mm	Column Dia ϕ mm	Net Weight Kgs
LCS-19	200 x 200	Cast Iron	6.50	Fine Adjustment	20	115	28	14.00
LCS-20	200 x 200	Cast Iron	6.50	Eccentric	200	110	28	14.50
LCS-21	200 x 200	Hardened	6.50	Centre	200	115	28	15.00

Cast Iron Comparator Stands

Luthra



LCS - 22



LCS - 23



LCS - 24

Model	Anvil Size mm	Anvil Type	Flatness Microns μ m	Gauging Bracket	Measuring Height (H) mm	Cross Arm (C) mm	Column Dia ϕ mm	Net Weight Kgs
LCS-22	200 x 200	Hardened	6.50	Eccentric	200	200	28	16.00
LCS-23	200 x 200	Hardened Serrated	6.50	Fine Adjustment	200	110	28	15.00
LCS-24	300 x 200	Hardened Serrated	7.00	Fine Adjustment	250	150	28	24.00



LCS - 25



LCS - 26



LCS - 27

Model	Anvil Size mm	Anvil Type	Flatness Microns μm	Gauging Bracket	Measuring Height (H) mm	Cross Arm (C) mm	Column Dia ϕ mm	Net Weight Kgs
LCS-25	300 x 200	Hardened Serrated	7.00	Eccentric	250	200	28	25.00
LCS-26	300 x 250	Hardened	7.00	Centre	250	150	28	29.00
LCS-27	300 x 250	Hardened Serrated	7.00	Eccentric	250	150	28	30.00

Cast Iron Comparator Stands

Luthra



LCS - 28



LCS - 29



LCS - 30

Model	Anvil Size mm	Anvil Type	Flatness Microns μm	Gauging Bracket	Measuring Height (H) mm	Cross Arm (C) mm	Column Dia \varnothing mm	Net Weight Kgs
LCS-28	300 x 300	Cast Iron	7.50	Centre	250	150	28	21.50
LCS-29	300 x 300	Cast Iron	7.50	Fine Adjustment	250	150	28	22.00
LCS-30	300 x 300	Cast Iron	7.50	Eccentric	250	200	28	23.00



LCS - 31



LCS - 32



LCS - 33

Model	Anvil Size mm	Anvil Type	Flatness Microns μm	Gauging Bracket	Measuring Height (H) mm	Cross Arm (C) mm	Coulmn Dia \varnothing mm	Net Weight Kgs
LCS-31	300 x 300	Cast Iron	7.50	Double Eccentric	250	200	28	27.00
LCS-32	300 x 300	Hardened	7.50	Fine Adjustment	250	150	28	32.00
LCS-33	300 x 300	Hardened	7.50	Eccentric	250	150	28	32.00