

Depth Gauge & Universal Test Set

DIAL DEPTH GAUGE



K158/3

K158/D

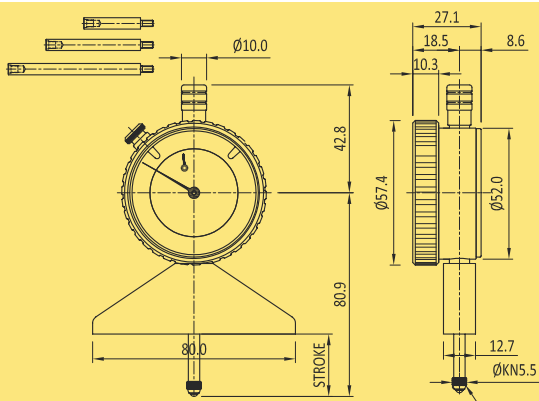

METRIC

Bezel dia.	Type	Reading	Range	Graduation
56mm	K158A/0	0.1mm	0-200mm	10-0
	K158/3	0.01mm	0-200mm	100-0

INCH

Bezel dia.	Type	Reading	Range	Graduation
56mm	K158/1	0.001"	0-8"	100-0

DIGITAL

Bezel dia.	Type	Reading	Range
56mm	K158/D	0.001 mm/0.00005"	0-200 mm

ANSI (AGD)

Bezel dia.	Type	Reading	Range	Graduation
2 1/4"	K158/1B	0.001"	0-10"	100-0

FEATURES

- Every gauge carries a calibration certificate giving actual values
- Suitable for quick and easy measurements of depths.
- Base with 80 mm length: hardened and ground to a high degree of flatness
- Supplied with a set of extension rods
- Supplied with Tungsten Carbide contact point for longer life

UNIVERSAL TEST SET



UI02

METRIC

Bezel dia.	Type	Reading	Range	Graduation
38mm	UI01	0.01mm	2.0mm	0-50-0
	UI02			0-100

INCH

Bezel dia.	Type	Reading	Range	Graduation
38mm	UI51	0.001"	0.1"	0-50-0
	UI52			0-100

ANSI (AGD)

Bezel dia.	Type	Reading	Range	Depth
1 1/2"	U51	0.001"	0.1"	0-50-0
	U52			0-100

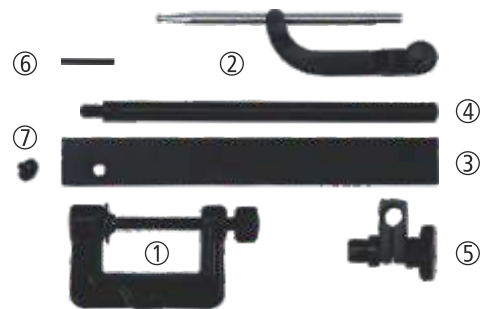

1. G Clamp 2. Swinging Arm Assembly 3. Tool post holder
4. Holding Rod 5. Universal Clamp 6. Tommy Bar 7. Anvil

FEATURES

- Every gauge carries a calibration certificate giving actual values
- Consists of back Plunger dial Gauge, 'G' clamp, universal clamp, swinging arm assembly, tool post holder, holding rod, tommy bar and anvil
- Swinging arm assembly enables the back plunger dial gauge to be used for internal work up to a depth of 40 mm similar to a lever type gauge
- 'G' Clamp, tool post holder, holding rod and universal Clamp allows multiple types of mounting possibilities
- Versatile combinations, allow gauging applications like concentricity checks, alignment of machine tools, testing parallelism and surface plate work

Dial Thickness Gauge



THROAT DEPTH: 30-200 mm



130



138



138D



142D



145



150

METRIC

Bezel dia.	Type	Reading	Range	Graduation	Throat Depth
56 mm	K130/0	0.1 mm	10 mm	0-10	30 mm
	K130/3	0.01 mm	10 mm	0-100	30 mm
	K130/6	0.002 mm	2 mm	0-20	30 mm
	K130/7	0.002 mm	5 mm	0-20	30 mm
	K138A/0	0.1 mm	25 mm	0-10	50 mm
	K138A/0L	0.1 mm	25 mm	0-10	50 mm
	K138/3	0.01 mm	25 mm	0-100	50 mm
	K138/3L	0.01 mm	25 mm	0-100	50 mm
	K142/0	0.1 mm	10 mm	0-10	100 mm
	K142/3	0.01 mm	10 mm	0-100	100 mm
	K145/0	0.1 mm	10 mm	0-10	200 mm
	K145/3	0.01 mm	10 mm	0-100	200 mm
K150A/0	0.1 mm	25 mm	0-10	200 mm	
K150/3	0.01 mm	25 mm	0-100	200 mm	

INCH

Bezel dia.	Type	Reading	Range	Graduation	Throat Depth
2 1/4"	K130/1	0.001"	0.5"	0-100	1.2"
	K130/8	0.0001"	0.05"		1.2"
	K130/9	0.0001"	0.2"		1.2"
	K138/1	0.001"	1.0"		2"
	K138/1L	0.001"	1.0"		2"
	K142/1	0.001"	0.5"		4"
	K145/1	0.001"	0.5"		8"
	K150/1	0.001"	1.0"		8"

DIGITAL

Bezel dia.	Type	Reading	Range	Throat Depth
56 mm	K130/D	0.001mm/ 0.00005"	12.5 mm/ 0.5"	30 mm
	K138/D		25 mm/ 1"	50 mm
	K142/D		12.5 mm/ 0.5"	100 mm
	K145/D		12.5 mm/ 0.5"	200 mm
	K150/D		25 mm/ 1"	200 mm

ANSI (AGD)

Bezel dia.	Type	Reading	Range	Graduation	Throat Depth
2 1/4"	K130/1B	0.001"	0.5"	0-100	1.2"
	K130/8B	0.0001"	0.05"		1.2"
	K130/9B	0.0001"	0.2"		1.2"
	K138/1B	0.001"	1.0"		2"
	K138/1LB	0.001"	1.0"		2"
	K142/1B	0.001"	0.5"		4"
	K145/1B	0.001"	0.5"		8"
	K150/1B	0.001"	1.0"		8"

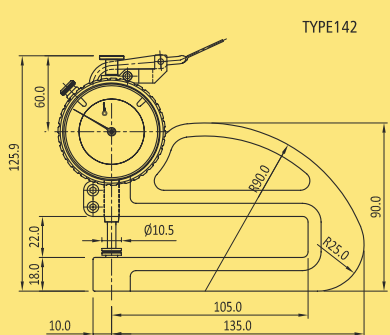
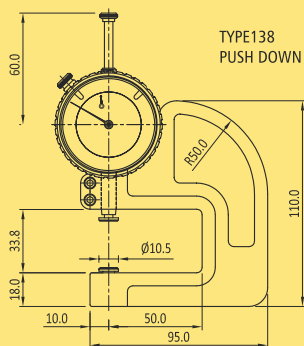
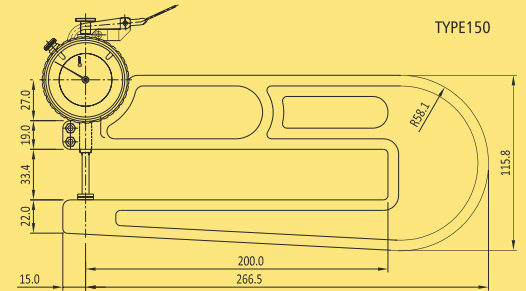
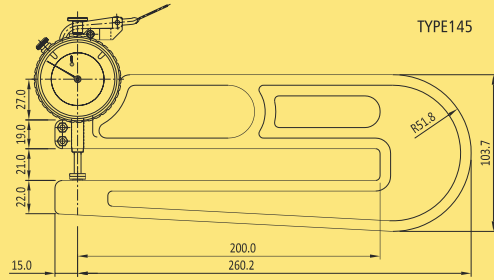
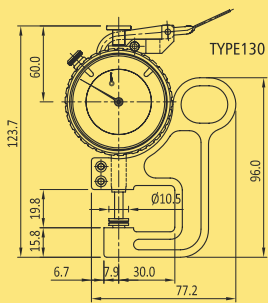

FEATURES

- Every gauge carries a calibration certificate giving actual values
- For quick measurement of thickness of sheets, paper, leather etc
- In series K130, K138/L and K142, K145, K150 measurement pressure is independent of the user, resulting in accurate readings of thickness
- K138 'Push Down Type' thickness gauge is particularly useful where fine measurement is not required - for example plywood
- Well-balanced frames and handgrips coupled with lightweight make these gauges easy to use for measurement
- Supplied with Ø10 mm flat anvil as standard. Can also be supplied with Ø20 mm flat anvil on request

Dial Bore Gauge

RANGE: 4-6MM

RANGE: 6-10MM



K439

K539

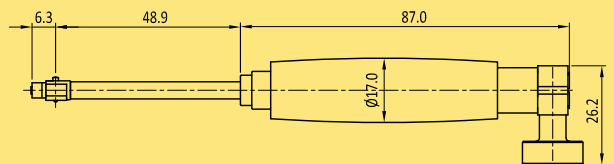
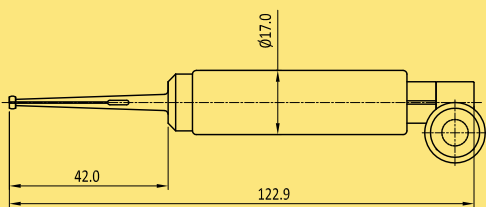

Type	Reading	Range
K439	0.01mm	4-6 mm

Type	Reading	Range
K539	0.01mm	6-10 mm

FEATURES

- For easy and accurate measurement of small inside diameters.
- The radial displacement of split ball anvil is converted to axial displacement of the measuring rod, which is shown on the dial indicator.
- Supplied with 4 interchangeable Measuring heads i.e. 4-4.6 mm, 4.5-5.1 mm, 5-5.6 mm, 5.5-6.1 mm)
- Supplied in a sleek sturdy case.
- Every gauge carries calibration certificate.

FEATURES

- For easy and accurate measurement of small inside diameters.
- 2 point type Design
- Supplied with 9 interchangeable anvils (extension) in steps of 0.5 mm from 6-10 mm
- Supplied in a sleek sturdy case.
- Every gauge carries calibration certificate

Dial Bore Gauge



RANGE: 10-18 mm



K639

RANGE: 18-50 mm



K703

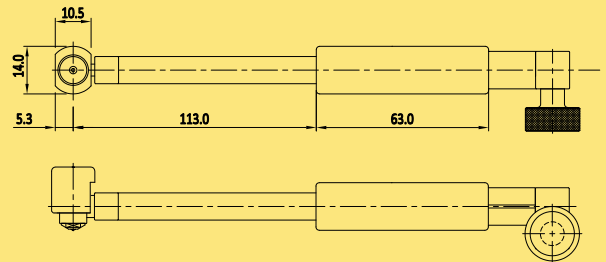
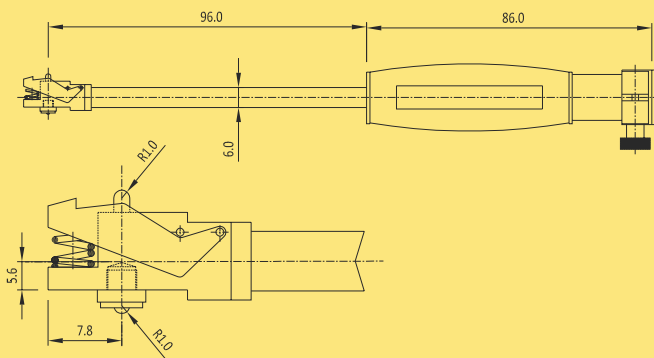

WITHOUT DIAL GAUGE

Type	Depth
K600	100 mm

METRIC (WITH DIAL GAUGE)

Bezel dia	Type	Reading	Depth	Graduation
40 mm	K639	0.01 mm	100 mm	0-50-0

INCH (WITH DIAL GAUGE)

Bezel dia	Type	Reading	Depth	Graduation
1 5/8"	K641	0.001"	4"	0-50-0

DIGITAL (WITH DIAL GAUGE)

Bezel dia	Type	Reading	Depth
56 mm	K60DP	0.001 mm/0.00005"	100 mm
56 mm	K60D	0.01 mm/0.0005"	100 mm

FEATURES

- Every gauge carries a calibration certificate giving actual values
- Measures small bores from 10 mm to 18 mm
- High wear resistance due to carbide-tipped fixed and moving anvils
- Wide bridge ensures automatic centering in the bore
- Self-centralizing feature of this bore gauge ensures that measurement can be done with minimum skill
- Supplied in a sleek wooden case containing measuring anvils and extension rods with necessary tools

WITHOUT DIAL GAUGE

Type	Depth
K700	110 mm

METRIC (WITH DIAL GAUGE)

Bezel dia	Type	Reading	Depth	Graduation
56 mm	K703	0.01 mm	110 mm	0.50-0
	K709	0.002 mm		0-10-0
	K717	0.001 mm		0-100-0

INCH (WITH DIAL GAUGE)

Bezel dia	Type	Reading	Depth	Graduation
56 mm	K753	0.0005"	4.5"	0-25-0
	K761	0.0001"		0-50-0

DIGITAL (WITH DIAL GAUGE)

Bezel dia	Type	Reading	Depth
56 mm	K70DP	0.001 mm/0.00005"	110 mm
56 mm	K70D	0.01 mm/0.0005"	110 mm

FEATURES

- Every gauge carries a calibration certificate giving actual values
- Highly versatile 18-50 mm bore gauge covers a large range for which one needs to generally purchase 2 bore gauges having ranges Ø18-35 mm and Ø35-60 mm
- High wear resistance due to carbide-tipped fixed and moving anvils
- Wide bridge ensures automatic centering in the bore
- Self-centralizing feature of this bore gauge ensures that measurement can be done with minimum skill
- Supplied in a sleek wooden case containing measurement anvils and extension rods with necessary tools



Dial Bore Gauge

RANGE: 50-150 mm



K803

Also available with digital dial gauge

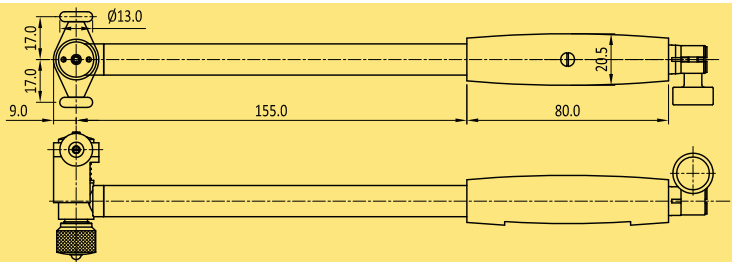

Depth Extension 200mm

WITHOUT DIAL GAUGE

Type	Depth
K800	150 mm

METRIC (WITH DIAL GAUGE)

Bezel dia	Type	Reading	Depth	Graduation
56 mm	K803	0.01 mm	150 mm	0-50-0
	K809	0.002 mm		0-10-0
	K817	0.001 mm		0-100-0

INCH (WITH DIAL GAUGE)

Bezel dia	Type	Reading	Depth	Graduation
56 mm	K853	0.0005"	6"	0-25-0
	K861	0.0001"		0-50-0

DIGITAL (WITH DIAL GAUGE)

Bezel dia	Type	Reading	Depth
56 mm	K80DP	0.001 mm/0.00005"	150 mm
56 mm	K80D	0.01 mm/0.0005"	150 mm

FEATURES

- Every gauge carries a calibration certificate giving actual values
- Bore gauge covering a range of 50-150 mm, is widely used by Automobile, Aircraft, Engine and Pump manufacturers
- High wear resistance due to carbide-tipped fixed and moving anvils
- Extra wide bridge ensures automatic centering in the bore. Self-centralizing feature of this bore gauge ensures that measurement can be done with minimum skill
- Furnished in a sleek wooden case containing measurement anvils and extension rods with necessary tools

RANGE: 50-150 mm (SHALLOW)



Also available with digital dial gauge

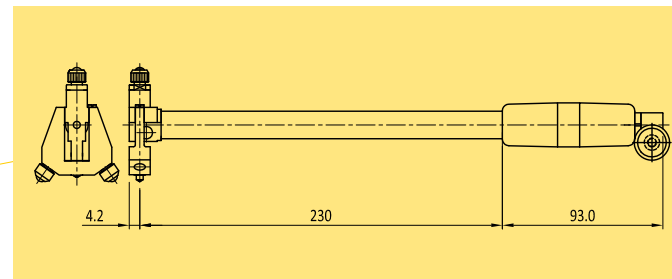

WITHOUT DIAL GAUGE

Type	Depth
K800S	250 mm

METRIC (WITH DIAL GAUGE)

Bezel dia	Type	Reading	Depth	Graduation
56 mm	K803S	0.01 mm	250 mm	0-50-0
	K809S	0.002 mm		0-10-0
	K817S	0.001 mm		0-100-0

INCH (WITH DIAL GAUGE)

Bezel dia	Type	Reading	Depth	Graduation
56 mm	K853S	0.0005"	10"	0-25-0
	K861S	0.0001"		0-50-0

DIGITAL (WITH DIAL GAUGE)

Bezel dia	Type	Reading	Depth
56 mm	K80DPS	0.001 mm/0.00005"	250 mm
56 mm	K80DS	0.01 mm/0.0005"	250 mm

FEATURES

- Bore gauge covering a range of 50-150 mm, is widely used in Automobile, Aircraft, Engine and Pump manufacturers.
- High wear resistance due to carbide-tipped fixed and moving anvils.
- Extra wide bridge ensures automatic centering in the bore. Self-centralizing feature of this bore gauge ensures that the measurement can be done with minimum of skill.
- Furnished in a sleek wooden case containing measurement anvils and extension rods with necessary tools.
- Each gauge carries a calibration certificate giving actual values.
- Suitable to measure blind bore

Dial Bore Gauge



RANGE: 150-250 MM

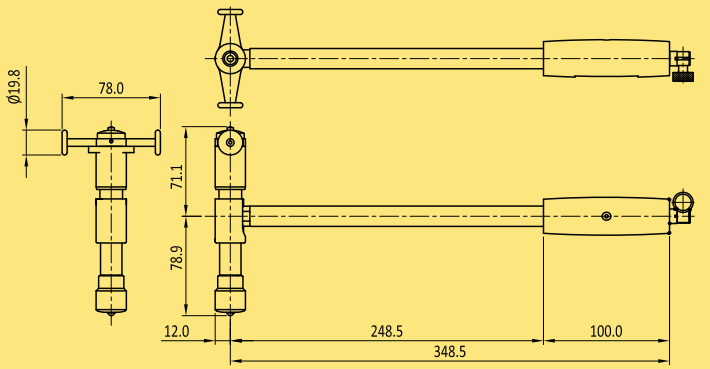

Depth Extension 200mm

WITHOUT DIAL GAUGE

Type	Depth
K900	250 mm

METRIC (WITH DIAL GAUGE)

Bezel dia	Type	Reading	Depth	Graduation
56 mm	K903	0.01 mm	250 mm	0-50-0
	K909	0.002 mm		0-10-0
	K917	0.001 mm		0-100-0

INCH (WITH DIAL GAUGE)

Bezel dia	Type	Reading	Depth	Graduation
56 mm	K953	0.0005"	10"	0-25-0
	K961	0.0001"		0-50-0

DIGITAL (WITH DIAL GAUGE)

Bezel dia	Type	Reading	Depth
56 mm	K90DP	0.001 mm/0.00005"	250 mm
56 mm	K90D	0.01 mm/0.0005"	250 mm

FEATURES

- Every gauge carries a calibration certificate giving actual values.
- Bore gauges covering range of 150-250 mm, is widely used by the Automobile & Aircraft, Engine and pump manufacturers, among other industries.
- Designed using Carbide for fixed & Moving Anvils Ensures High wear Resistance.
- Extra wide bridge Design ensures automatic self-centralizing in the bore feature of this bore gauge ensures that measurement can be done with minimum skill.
- Packed in a sleek wooden case containing measurement anvils and extension rods with necessary tools.

RANGE: 250-450 MM

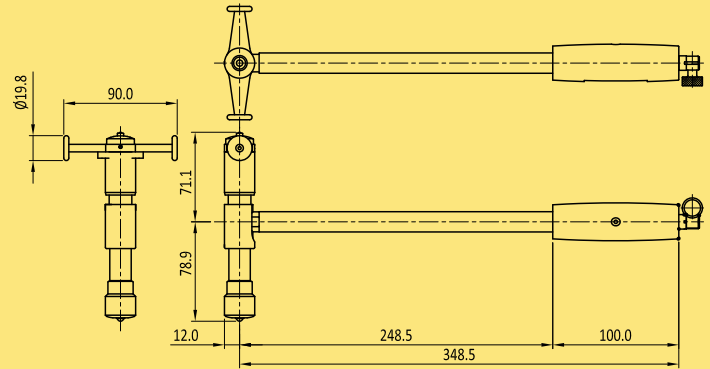

Depth Extension 200mm

WITHOUT DIAL GAUGE

Type	Depth
K1000	250 mm

METRIC (WITH DIAL GAUGE)

Bezel dia	Type	Reading	Depth	Graduation
56 mm	K1003	0.01 mm	250 mm	0-50-0
	K1009	0.002 mm		0-10-0
	K1017	0.001 mm		0-100-0

INCH (WITH DIAL GAUGE)

Bezel dia	Type	Reading	Depth	Graduation
56 mm	K1053	0.0005"	10"	0-25-0
	K1061	0.0001"		0-50-0

DIGITAL (WITH DIAL GAUGE)

Bezel dia	Type	Reading	Depth
56 mm	K10DP	0.001 mm/0.00005"	250 mm
56 mm	K10D	0.01 mm/0.0005"	250 mm

FEATURES

- Every gauge carries a calibration certificate giving actual values.
- Bore gauges covering range of 150-250 mm, is widely used by the Automobile & Aircraft, Engine and pump manufacturers, among other industries.
- Designed using Carbide for fixed & Moving Anvils Ensures High wear Resistance.
- Extra wide bridge Design ensures automatic self-centralizing in the bore feature of this bore gauge ensures that measurement can be done with minimum skill.
- Packed in a sleek wooden case containing measurement anvils and extension rods with necessary tools



Internal Groove Caliper



Graduation (mm)	Measuring Range (mm)	Indicating Range (mm)	Indicating Error (mm)	Weight (g)	Contact Point (H)	Max. Measuring Depth A (mm)	Entrance Dia. ØD (mm)	Groove Depth. D (mm)	Min. Depth. Width B (mm)
0.01	10-120	±5.0	±0.03	500	2,3,4,5,6,7,8,9,10	50	10	10	2.5

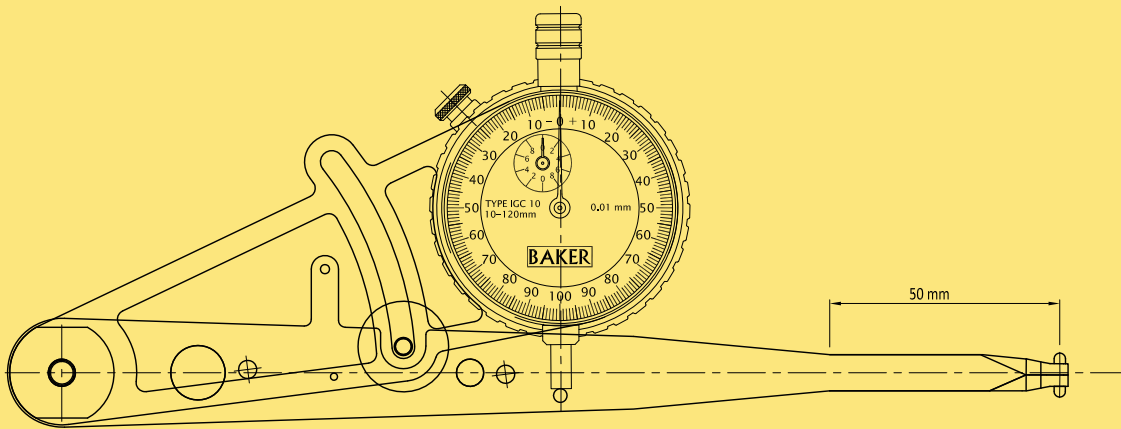

STANDARD ANVILS SUPPLIED WITH GAUGE

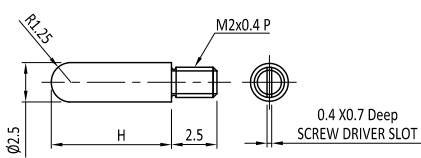

CODE	H	CODE	H
IGC-SPT1-1	2.0	IGC-SPT1-6	7.0
IGC-SPT1-2	3.0	IGC-SPT1-7	8.0
IGC-SPT1-3	4.0	IGC-SPT1-8	9.0
IGC-SPT1-4	5.0	IGC-SPT1-9	10.0
IGC-SPT1-5	6.0		

OPTIONAL ACCESSORIES ON REQUEST

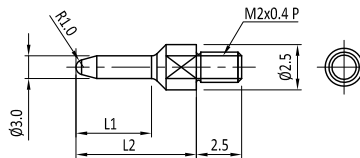

CODE	L1	L2	CODE	L1	L2
IGC-SPT3-1	2.0	4.5	IGC-SPT3-6	7.0	9.5
IGC-SPT3-2	3.0	5.5	IGC-SPT3-7	8.0	10.5
IGC-SPT3-3	4.0	6.5	IGC-SPT3-8	9.0	11.5
IGC-SPT3-4	5.0	7.5	IGC-SPT3-9	10.0	12.5
IGC-SPT3-5	6.0	8.5			

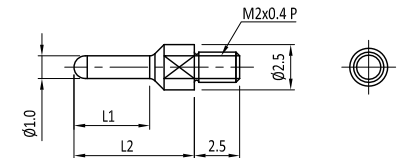

CODE	L1	L2	CODE	L1	L2
IGC-SPT2-1	2.0	4.5	IGC-SPT2-6	7.0	9.5
IGC-SPT2-2	3.0	5.5	IGC-SPT2-7	8.0	10.5
IGC-SPT2-3	4.0	6.5	IGC-SPT2-8	9.0	11.5
IGC-SPT2-4	5.0	7.5	IGC-SPT2-9	10.0	12.5
IGC-SPT2-5	6.0	8.5			

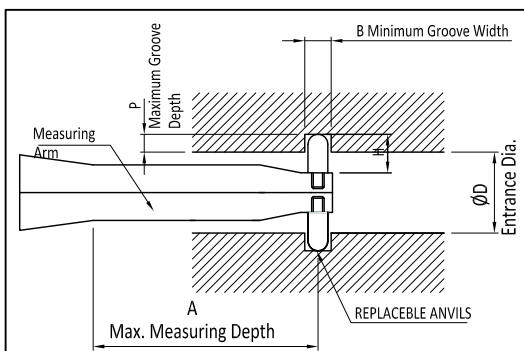

FEATURES

- Internal caliper gauge to measure internal diameter of cylindrical workpiece and groove diameters.
- It can measure groove diameter of "O" ring by modifying spare contact point.
- Set dimension within ± 5 mm (indicating range 10 mm) can be comparatively measured
- For different groove shapes & sizes optional replaceable anvils available on request.
- Adjustable frame mechanism



TYRE TREAD DEPTH GAUGE



TTG01

CRANKSHAFT WEB DEFLECTION GAUGE



CS1

Type	Reading	Range	Graduation
CS1	0.01 mm	60-600 mm	0-50
CS2	0.0005 "	2.4-23.6 "	0-20
CS3	0.01 mm	60-600 mm	0-25-0
CS4	0.0005 "	2.4-23.6 "	0-10-0

Excessive web deflection is dangerous for the engine. The Cause may be faulty or damaged crankshaft, damaged bearing, poor bearing alignment, excessive bearing clearance or slackness, faulty flanging to transmission, flywheel or vee belt pulley etc.

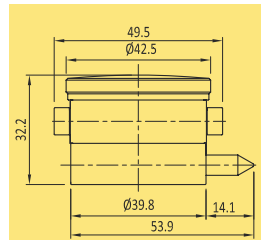

FEATURES

- Every gauge carries a calibration certificate giving actual values
- Crankshaft Gauge measures the Web deflection of a crankshaft
- The BAKER Crankshaft Gauge is developed to identify and avoid the problems mentioned above
- The Gauge covers web-to-web distance of 60-600 mm
- Supplied in a sleek wooden box
- Gauge contacts are pointed & fit into dimples in the webs. A heavy spring pressure ensures that the Gauge is restrained but is free to turn in relation to the crankshaft. An adjustable balance weight restrains the Gauge against rotation of the crankshaft, so that the dial always faces the inspector

HOW TO USE BAKER CRANKSHAFT GAUGE ?

- Determine the distance (a) between two Webs. Assemble the extension (2) and fixed gauging point (3) and screw this assembly into the threaded bush of the dial gauge unit opposite to live point (1). Overall length from tip of fully extended live point (1) to tip of fixed point (3) should be about 1 to 2 mm greater than web distance (a)
- The back of the dial Gauge unit takes the balance weight to keep the dial facing upward while the Gauge is suspended between the webs during Crankshaft rotation. Use center bush for horizontal upward position and outer bush for inclined upward position. Without balance weight, the indicator adopts a face down position
- Place the Gauge between webs of Crankshaft so that gauging points are located in punch holes (4), center punched where measurement of deflection is required. First, place spring loaded live point (1) in one of the two punch holes (4), then locate fixed point (3) in other punch hole
- Set dial pointer to 20 on (metric) dial by rotating the indicator bezel. Turn Crankshaft by hand & observe pointer movement on dial
- Read deflections at various positions of the crankshaft revolution as set out in manufacturer's inspection procedure

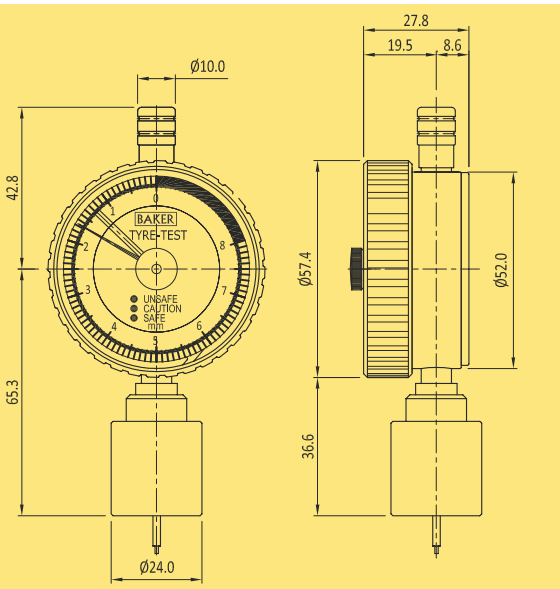
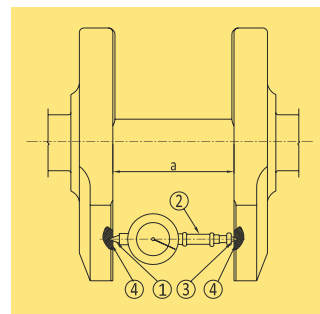

Bezel dia	Type	Reading	Range	Graduation
56 mm	TTG01	0.1 mm	8 mm	8 - 0
	TTG02	0.004 in	0.32 in	0.32 - 0

A Gauge developed specifically to monitor compliance with safety requirements for minimum tread depth of automobile tyres. Additionally, it is useful for gauging general tyre wear in the range 0-8 mm.

FEATURES

- Every gauge carries a calibration certificate giving actual values
- The gauge gives accurate readings to 0.1mm / 0.004Inch
- A 'telltale' maximum reading pointer is fitted to retain measurement, allowing the gauge to be applied to tyre positions where it cannot be easily read
- The dial has coloured bands for quick and easy reading

Special Instruments

BALL DIAMETER

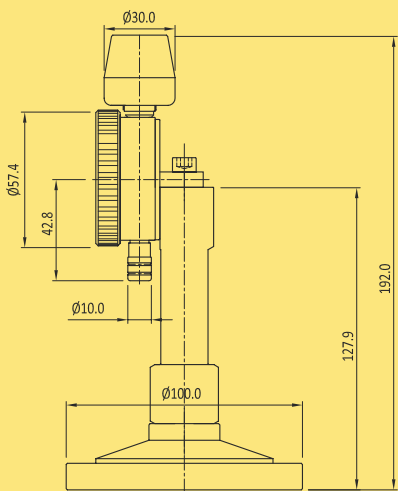

Type	Range (mm)	Reading (mm)
BD01	1-10	0.01
BD02	10-12	0.02
BD03	12-14	0.02
BD04	14-16	0.02
BD05	16-18	0.02
BD06	18-20	0.02
BD07	20-22	0.02
BD08	22-24	0.02
BD09	24-26	0.02
BD10	26-28	0.02
BD11	28-30	0.02

FEATURES

- Every gauge carries a calibration certificate giving actual values
- Gauge measures ball diameter quickly
- Minimum skill required
- Inspector needs to just place the ball over the circular cup & the direct reading of ball diameter is shown
- Available in variety of sizes

OUTER DIAMETER



Type	Range (mm)	Reading (mm)
OD01	50-70	0.1
OD02	70-90	0.1
OD03	90-110	0.1
OD04	110-130	0.1
OD05	130-150	0.1
OD06	150-175	0.5
OD07	175-200	0.5
OD08	200-225	0.5
OD09	225-250	0.5
OD10	250-275	0.5
OD11	275-300	0.5

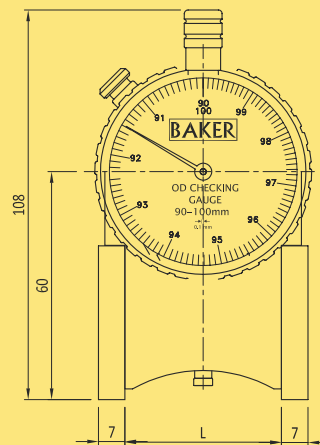

TYPE NO	RANGE	L
OD01	50-70	72
OD02	70-90	33
OD03	90-110	41
OD04	110-130	49
OD05	130-150	58
OD06	150-175	61
OD07	175-200	70
OD08	200-225	80
OD09	225-250	89
OD10	250-275	99
OD11	275-300	108.

FEATURES

- Every gauge carries a calibration certificate giving actual values
- Gauge measures OD of circular parts quickly
- Inspector needs to just place the gauge over circular periphery and the direct reading of OD is shown on circular scale
- OD of stacked pipes can be easily measured at site in as is condition
- It is the simplest method of checking OD above 40 mm
- Minimum skill required
- Available in variety of sizes



RUBBER HARDNESS TESTER

Hardness is one of the most important properties which determine the suitability of any rubber component for its intended end use. Incorrect hardness may defeat the basic purpose for which the component is designed. Thus accurate and reliable determination of hardness is of extreme importance



Scale	Shore A	Shore D
Graduation	0-90	0-90
Range	10~90	30~90
Standard	JIS K 6253, JIS K 7215, ASTM D 2240 ISO 868, ISO 7619, DIN 53 505	JIS K 6253, JIS K 7215, ASTM D 2240 ISO 868, ISO 7619, DIN 53 505
Location area	Ø 18.0 mm.	Ø 18.0 mm.
Indenter	Blunt Taper	Sharp Point
Tip angle	35° ± 0.25°	30° ± 0.25°
Function	Maximum hand	Maximum hand
Mass	230 GMS	230 GMS
Test pressure	12.5 N	50.0 N

FEATURES

- Complete 360° clock
- Readings in units of hardness
- Ergonomic body design
- Models with maximum pointer available
- Delivered with calibration certificate
- Supplied with sturdy box
- The measuring tips are not interchangeable

APPLICATION

Shore A application

Rubber, elastomers, neoprene, silicone, vinyl, soft plastics, felt, leather and similar material

Shore D application

Plastics, Formica, epoxides, plexiglass etc.

Shore AO application

Foam, sponge etc.

DIAL SNAP GAUGE



DS25

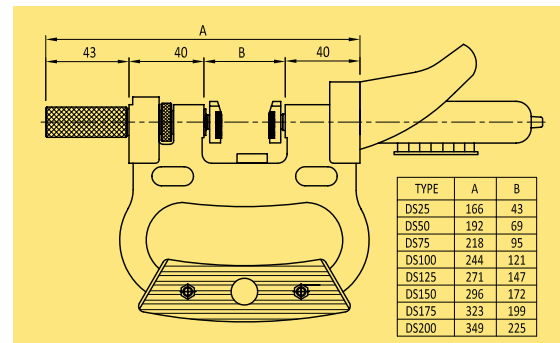

Note: Supplied without dial indicator

Type	Measuring Range (mm)
DS25	0-25
DS50	25-50
DS75	50-75
DS100	75-100

Type	Measuring Range (mm)
DS125	100-125
DS150	125-150
DS175	150-175
DS200	175-200

FEATURES

- Designed for quick GO / NOT GO gauging of diameters of cylindrical parts either in process or post process
- Adjustable spindle & sensing spindle are manufactured out of graded steel
- Spindles are hardened and ground including screw threads
- Carbide ground and lapped tip of measuring faces ensures maximum wear resistance
- For quick entry, chamfer provided on front edges
- Constant measuring force, which is a result of an in-bulit spring, eliminates user error
- For easy reading, the dial indicator can be rotated and locked
- Best suited for inspection of continuous / Batch production items
- Setting is done with the help of Gauge Blocks / Cylindrical setting Masters
- Any standard Dial indicator with Ø8h6 mm holding shank can be fitted easily
- Also used with Electronic probe & digital dial gauge

Application

For measuring quick & accurate measurement of all kinds of Outer Diameter up to 100 mm

Universal Gauge



The Bowers Universal Gauge's ingenious modular design enables it to be quickly configured to suit almost any measuring challenge, both internal and external. The Universal's clever constant measuring pressure device ensures accuracy and consistency of reading. A large variety of measuring contacts and adaptors are available for the Universal Gauge enabling countless measuring tasks to be completed with ease. Accessories for the measurement of threads, grooves, splines, gears, hole centers and many others are available as standard and special adaptations for more non-standard applications can be quoted on request.

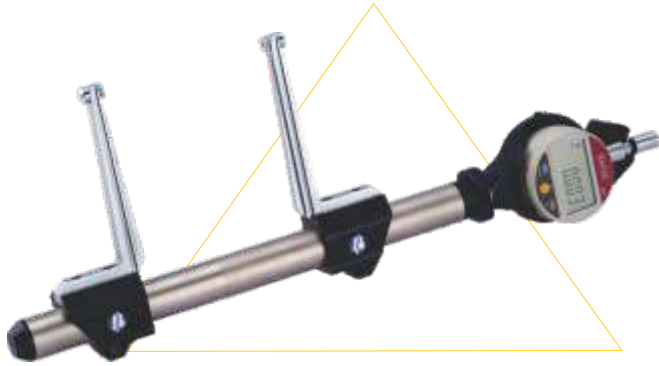

FEATURES

- Internal and External measurement
- Large measuring range possible 0-3000 mm (0-118") with interchangeable extensions
- Constant measuring force
- Digital or Mechanical readout display
- Large range of accessories for standard measurement of threads, grooves, splines, diameters, lengths, shallow spigots and recess diameters etc.
- Special anvil designs available on request



APPLICATIONS

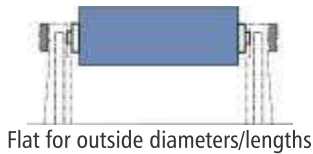

Flat for outside diameters/lengths

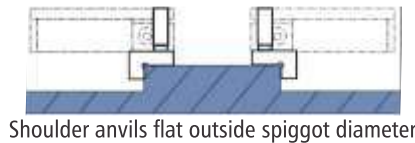

Shoulder anvils flat outside spigot diameter

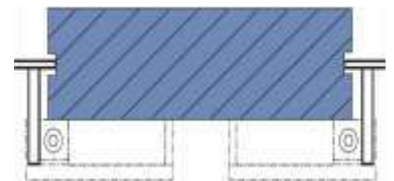

Disc anvils for measuring external groove diameter



Spherical for inside diameters

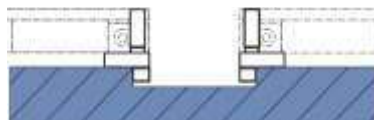

Semi-Cylindrical anvils for inside

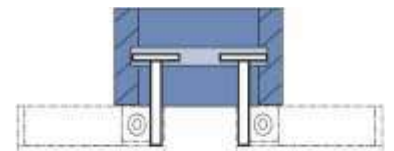

Disc anvils for measuring internal groove diameter

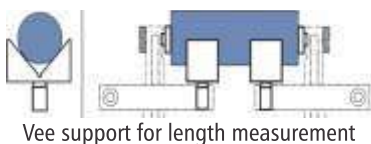

Vee support for length measurement

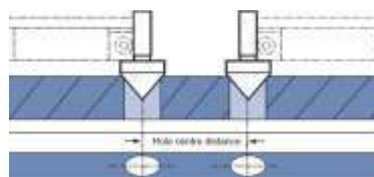

Cone anvils for measuring hole center distance

Harpenden Skinfold Caliper



HUMAN BODY FAT MEASUREMENT

FEATURES

- The Harpenden Skinfold Caliper is a precision instrument designed for use in the performance of Skinfold thickness measurements (from which estimates of body fat are derived) The use of this instrument has been well established and documented over the past 40 years
- Designed in 1958 in collaboration with D. J. M. Tanner, a prominent force in the use of Skinfold measurements in the derivation of body fat measurement
- It is the only Caliper CE marked under the Medical Devices Directive 93 / 42 / EEC for a Class 1 Device with Measuring Function and is calibrated using masters traceable to National Standards
- It is used all over the world in applications including diagnostics & research, nutrition/malnutrition, obesity, eating disorder assessment (especially in sports) and juvenile growth disorders
- It is supplied with a handbook which includes tables for body fat% versus Skinfold thickness in males & females of all ages based on the Durnin & Womersley systems
- It is also supplied with Body Assessment Software (Optional)



TECHNICAL INFORMATION

- Dial Graduation: 0.20 mm
- Measuring Range: 0 mm to 80 mm
- Measuring Pressure: 10 gms/mm² (constant over range)
- Accuracy: 99.00%
- Repeatability: 0.20 mm.

BODY ASSESSMENT SOFTWARE ON REQUEST

HARPENDEN SKINFOLD CALIPER BODY ASSESSMENT SOFTWARE

Assess a subjects :-

- Body fat % content
- Body fat % preferred level
- Body mass index
- Basal metabolic rate
- Lean body mass
- Fat mass
- Min/Max weight guide
- Child Bmi Growth Charts

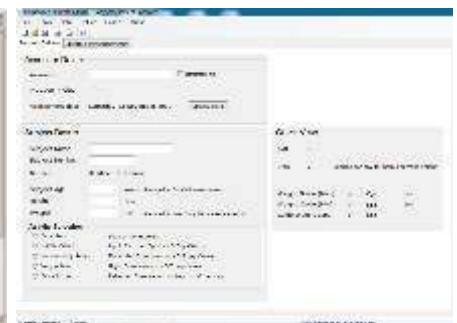
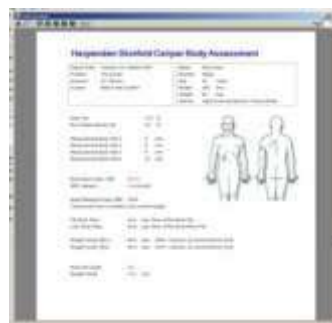
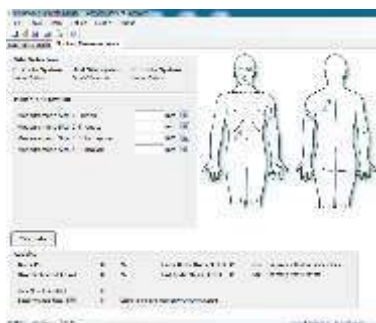



Dial Magnetic Stand

MAGNETIC STAND



MS Magnetic Stand

UNIVERSAL MAGNETIC STAND



MSF Magnetic Stand with fine adjustment



UMS Magnetic Stand

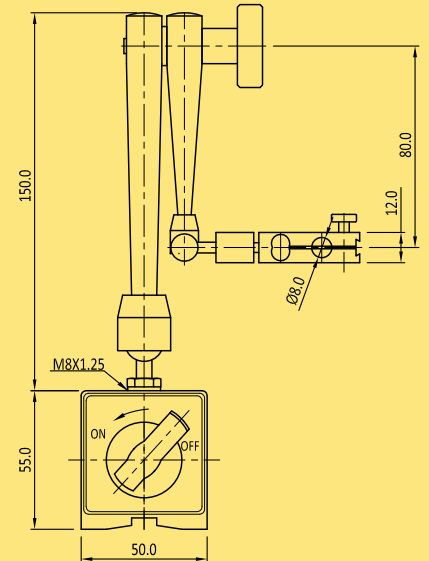
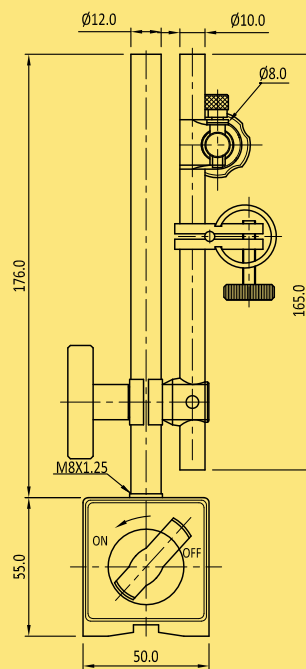
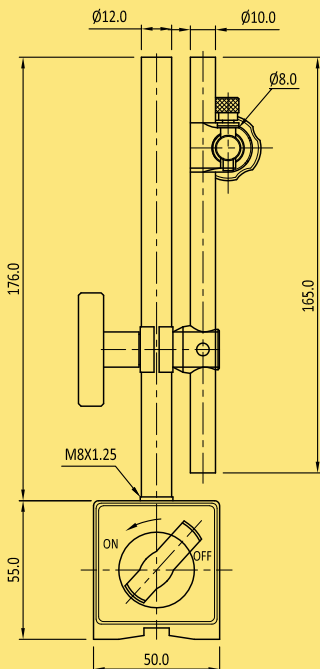

FEATURES

- Magnetic stand accepts all dial indicators and dial test indicators
- The On-Off switch offers instant mounting and dismounting without any adverse effect to the indicators or workpiece surface.
- With mechanical locking system.

SPECIFICATION

Type	Base Dimension (mm)	Magnetic Force (N)	Applicable Holding Stem	Fine Adjustment
MS	55 X 55 X 50	600	Ø4 mm, Ø8 mm, Ø3/8"	-
MSF	58 X 55 X 50	600	Ø4 mm, Ø8 mm, Ø3/8"	8 mm
UMS	60 X 55 X 50	800	Ø8 mm, Ø3/8" & Dovetail slot	9 mm

Dial Comparator Stand



PLAIN BASE



CS150

SERRATED BASE



CS200S

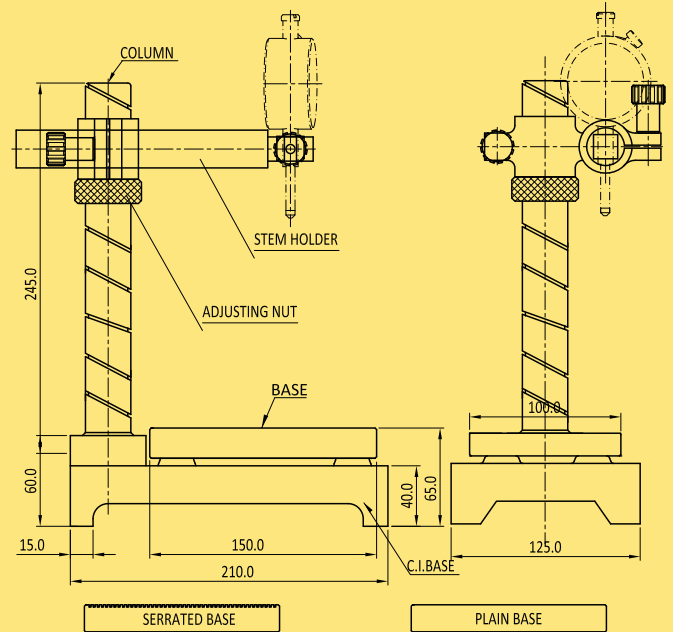
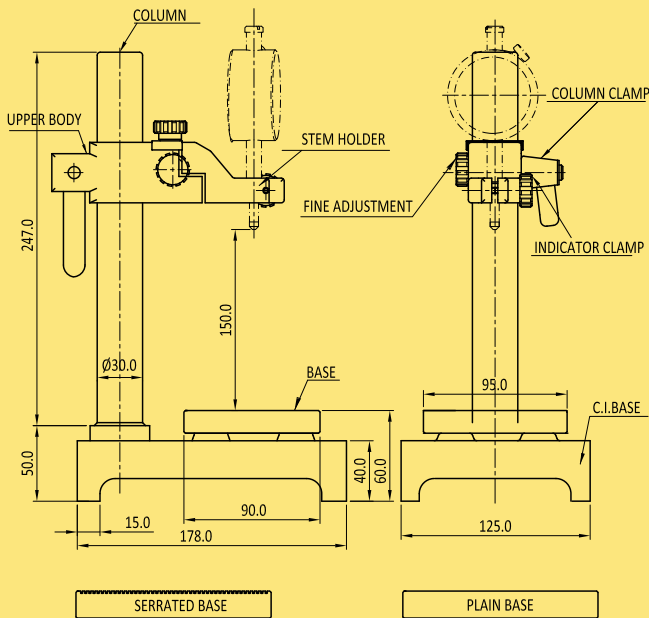

SPECIFICATION

Model	Measuring Range	Base Type	Base Size	Stem hole for dial	Fine adjustment
CS150	150 mm	Plain	90 mm x 95 mm	Ø8 mm	2 mm
CS150-S	150 mm	Serrated	90 mm x 95 mm	Ø8 mm	2 mm
CS200	200 mm	Plain	150 mm x 100 mm	Ø8 mm	Entire range
CS200-S	200 mm	Serrated	150 mm x 100 mm	Ø8 mm	Entire range

FEATURES

- Rigid cast iron base that enables precise measurement.
- The column has a helically threaded arm on which the dial gauge is fixed and can be accurately positioned on the job by means of a threaded nut
- The sliding arm allows the indicating devices to be brought in to any position above the plain table. This enables checking of work pieces of large dimensions.
- Available in plain and serrated steel base with flatness $3.0 \mu\text{m}$ and hardness HRC 60+2.