

13

Quick Guide to Precision Measuring Instruments



Micrometers



Calipers



Height Gages

INDEX

Quality Control.....	13-3
Micrometers.....	13-5
Micrometer Heads	13-11
Inside Measuring Instruments	13-15
Calipers	13-17
Height Gages	13-23
Depth Gages	13-27
Gauge Blocks	13-28
Dial Indicators, Digital Indicators and Test Indicators	13-29

Quick Guide to Precision Measuring Instruments

You can access our "Quick Guide to Precision Measuring Instruments" catalog pdf file here.
Get useful information about our instrument products, including measuring tools.



General Term in Measurement: Quality Control

Quality Control (QC)

Methods and their system for economically producing products or services of a quality that meets customer requirements.

Process Quality Control

Activities to control the manufacturing process, reduce product variation, and keep product variation low. Process improvement and standardization as well as technology accumulation are promoted through these activities.

Statistical Process Control (SPC)

Process quality control through statistical methods.

Population

Population A group of all items that have characteristics to be considered for improving and controlling processes and quality of product. Ordinarily, the population is the group that is going to be handled based on a sample.

Lot

Collection of product produced under the same conditions.

Sample

An item of product (or items) taken out of the population to investigate its characteristics.

Sample Size

Number of product items in the sample.

Bias

Value calculated by subtracting the true value from the mean of measurement values when multiple measurements are performed.

Dispersion, Imprecision

Variation in the values of a target characteristic in relation to the mean value. Standard deviation is usually used to represent the dispersion of values around the mean.

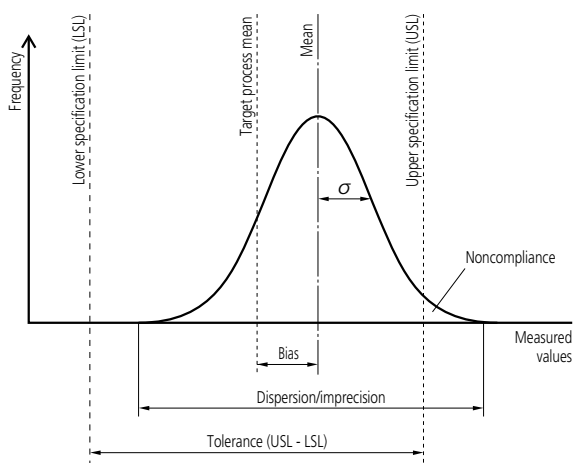

Histogram

A diagram that divides the range between the maximum and the minimum measurement values into several divisions and shows the number of values (appearance frequency) in each division in the form of a bar graph. This makes it easier to understand the rough average or the approximate extent of dispersion. A diagram indicating a symmetrical bell-shaped distribution shows what is called "normal distribution."

Process Capability

Process-specific performance demonstrated when the following conditions are met:

- The process is sufficiently standardized,
- Any causes of malfunctions are eliminated,
- The process is in a state of statistical control.

The process capability is represented by mean $\pm 3\sigma$ or 6σ when the quality characteristic output from the process shows normal distribution. This indicates standard deviation.

Process Capability Index (PC or Cp)

The index value is calculated by dividing the tolerance of a target characteristic by the process capability (6σ). The value calculated by dividing the difference between the mean (\bar{X}) and the standard value by 3 may be used to represent this index in cases of a unilateral tolerance. The process capability index assumes that a characteristic follows the normal distribution.

Note: If a characteristic follows the normal distribution, 99.74 % data is within the range $\pm 3\sigma$ from the mean.

Bilateral tolerance

$$C_p = \frac{USL - LSL}{6 \times \sigma}$$

USL: Upper specification limit
LSL: Lower specification limit

Unilateral tolerance ... If only the upper limit is stipulated

$$C_p = \frac{USL - \bar{X}}{3 \times \sigma}$$

Unilateral tolerance ... If only the lower limit is stipulated

$$C_p = \frac{\bar{X} - LSL}{3 \times \sigma}$$

Specific examples of a process capability index (C_p) (bilateral tolerance)

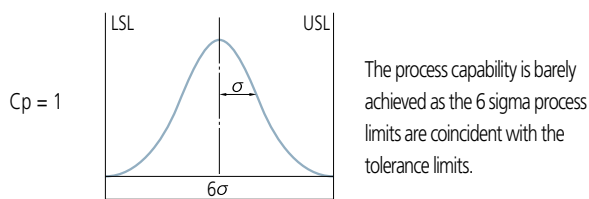

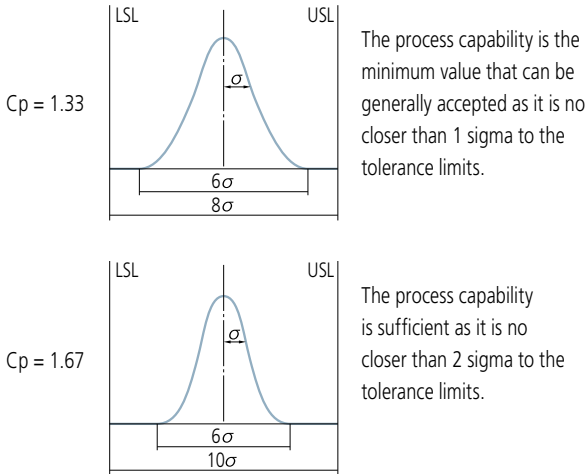

Note that Cp only represents the relationship between the tolerance limits and the process dispersion and does not consider the position of the process mean.

Note: A process capability index that takes into account the deviation between the specification center and the process mean is generally called Cpk. It is the upper tolerance (USL minus the mean) divided by 3 (half of process capability) or the lower tolerance (the mean value minus LSL) divided by 3, whichever is smaller.

Control Chart

Used to control the process by separating variations into those due to chance causes in the process and those due to a malfunction. It consists of one center line (CL) and the control limit lines rationally determined above and below it (UCL and LCL). It can be said that the process is in a state of statistical control if all points are within the upper and lower control limit lines without notable trends when the characteristic values that represent the process output are plotted. The control chart is a useful tool for controlling process output, and therefore quality.

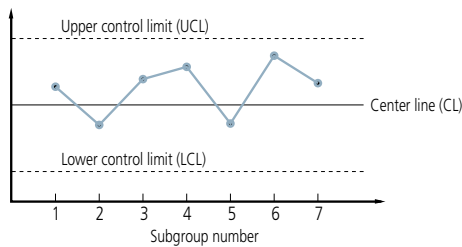

Chance Causes

These causes of variation are of relatively low importance. Chance causes are technologically or economically impossible to eliminate even if they can be identified.

X-R Control Chart

A control chart used for process control that provides the most information on the process. An X-R control chart consists of the following:

- A control chart that uses the mean of each subgroup for control to monitor abnormal bias of the process mean,
 - An R control chart that uses the range for control to monitor abnormal variation.
- Usually, both charts are used together.

How to Read the Control Chart

Typical trends of successive point position in the control chart that are considered undesirable are shown below. These determination rules only provide a guideline. Take the process-specific variation into consideration when making determination rules. Assuming that the upper and the lower control limits are 3 away from the center line, divide the control chart into six regions at intervals of 1 to apply the following rules. These rules are applicable to the X control chart and the X control chart. Note that these 'trend rules for action' were formulated assuming a normal distribution.

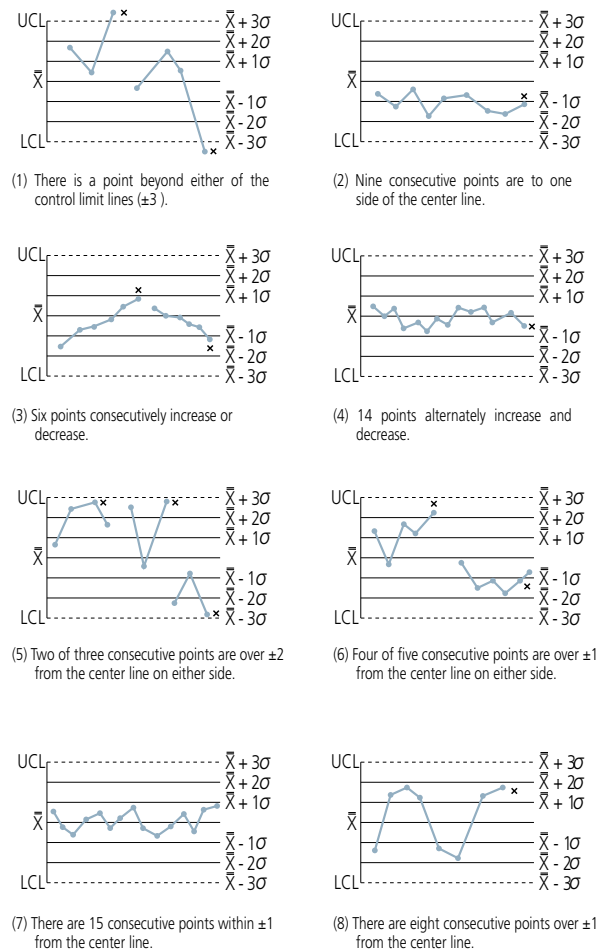

Note: This part of 'Quick Guide to Precision Measuring Instruments' (pages 13-3 and 13-4) has been written by Mitutoyo based on its own interpretation of the JIS Quality Control Handbook published by the Japanese Standards Association.

References

- JIS Quality Control Handbook (Japanese Standards Association) Z 8101:1981 Z 8101-1:1999 Z 8101-2:1999 Z 9020:1999 Z 9021:1998

Micrometers

Nomenclature

Standard Analog Outside Micrometer

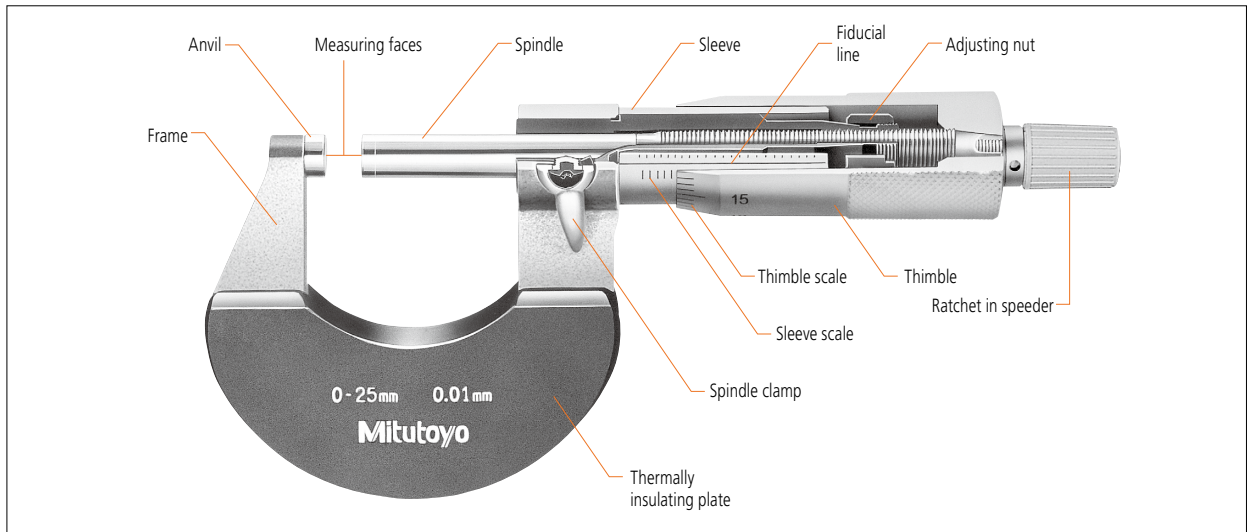

Digimatic Outside Micrometer



Special Purpose Micrometer Applications

For inside diameter, and narrow groove measurement

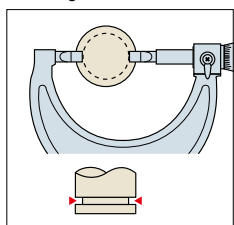

Blade micrometer

For small internal diameter, and groove width measurement

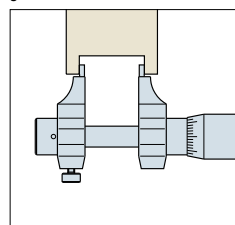

Inside micrometer, calliper type

For splined shaft diameter measurement

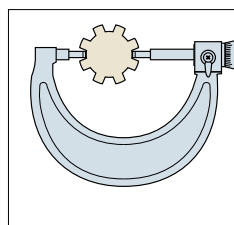

Spline micrometer

For pipe thickness measurement

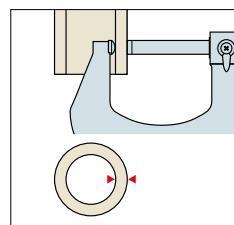

Spherical face micrometer

For root diameter measurement

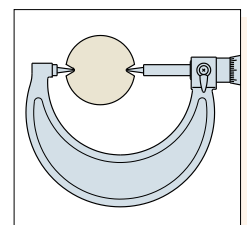

Point micrometer

Screw pitch diameter

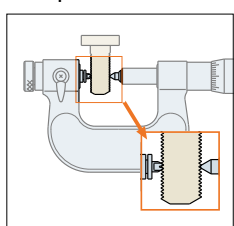

Screw thread micrometer

For root tangent measurement on spur gears and helical gears.

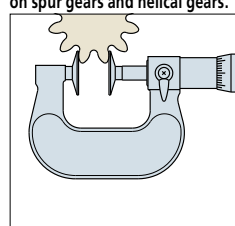

Disc type outside micrometer

Measurement of gear over-pin diameter

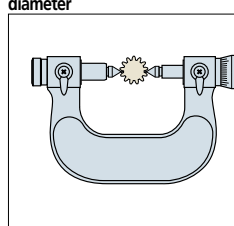

Ball tooth thickness micrometer

For measurement of 3- or 5-flute cutting tools

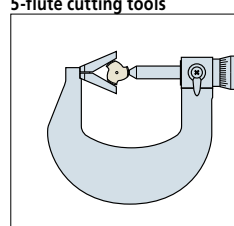

V-anvil micrometer

How to Read the Scale

■ Micrometer with standard scale (graduation: 0.01 mm)

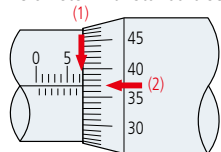

(1) Outer sleeve reading 7. mm
 (2) Thimble reading + 0.37 mm
 Micrometer reading 7.37 mm

Note: 0.37 mm (2) is read at the position where the sleeve fiducial line is aligned to the thimble graduations.

The thimble scale can be read directly to 0.01 mm, as shown above, but may also be estimated to 0.001 mm when the lines are nearly coincident because the line thickness is 1/5 of the spacing between them.



■ Micrometer with vernier scale (graduation: 0.001 mm)

The vernier scale provided above the sleeve index line enables direct readings to be made to within 0.001 mm.

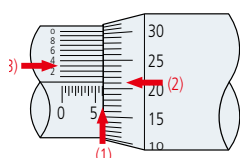

(1) Outer sleeve reading 6. mm
 (2) Thimble reading 0.21 mm
 (3) Reading from the vernier scale marking and thimble graduation line +0.003 mm
 Micrometer reading 6.213 mm

Note: 0.21 mm (2) is read at the position where the index line is between two graduations (21 and 22 in this case). 0.003 mm (3) is read at the position where one of the vernier graduations aligns with one of the thimble graduations.

■ Micrometer with mechanical-digit display (digital step: 0.001 mm)

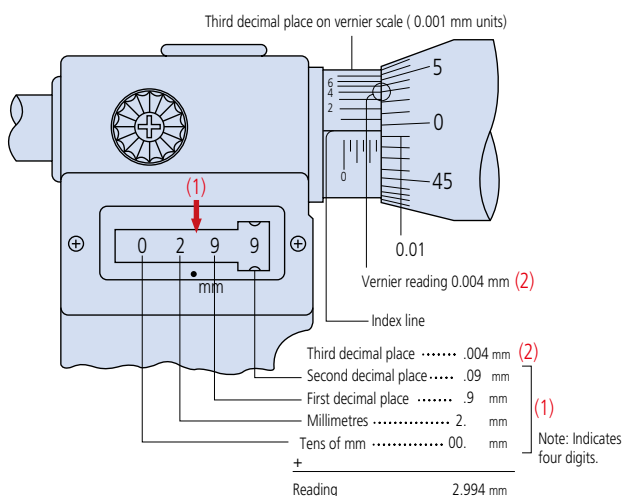

Note: 0.004 mm (2) is read at the position where a vernier graduation line corresponds with one of the thimble graduation lines.

Measuring Force Limiting Device

Varieties	Audible in operation	One-handed operation	Remarks
Ratchet stop 	Yes	Unsuitable	Audible clicking operation causes micro-shocks
Friction thimble (F type) 	No	Suitable	Smooth operation without shock or sound
Ratchet thimble 	Yes	Suitable	Audible operation provides confirmation of constant measuring force

Measuring Face Detail

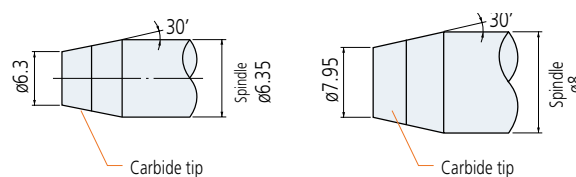

Note: The drawings above are for illustration only and are not to scale

Micrometer Expansion Due to Holding Frame with the Bare Hand

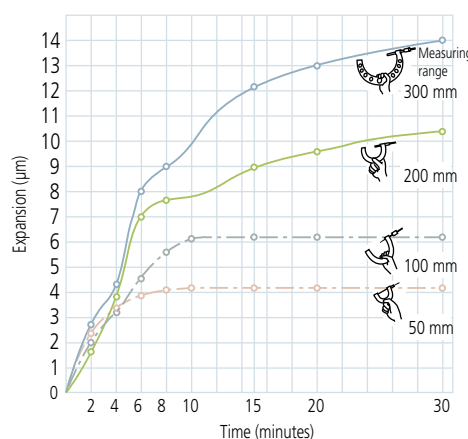

*The above graph shows micrometer frame expansion due to heat transfer from hand to frame when the frame is held in the bare hand which, as can be seen, may result in a significant measurement error due to temperature-induced expansion. When measuring by hand, care must be taken because the reference point will change (note that the graph values are not guaranteed values but experimental values).

Length Standard Expansion with Change of Temperature (for 200 mm Bar Initially at 20 °C)

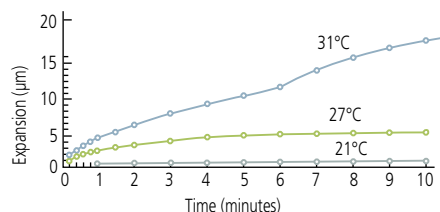

The above experimental graph shows how a particular micrometer standard expanded with time as people whose hand temperatures were different (as shown) held the end of it at a room temperature of 20 °C.

This graph shows that it is important not to set a micrometer while directly holding the micrometer standard but to make adjustments only while wearing gloves or lightly supporting the length standard by its heat insulators.

When performing a measurement, note that it takes time until the expanded micrometer standard returns to the original length.

Difference in Thermal Expansion Between Micrometer and Length Standard

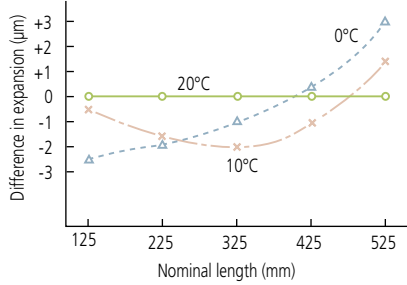

*Values are not guaranteed values but experimental values.

The above graph shows the results for each of the sizes from 125 through 525 mm at each temperature under the following time-series conditions.

1. The micrometer and its standard were left at a room temperature of 20°C for about 24 hours.
 2. The start point was adjusted using the micrometer standard after the temperature of the micrometer and the standard stabilized.
 3. The micrometer with its standard were left at the temperatures of 0°C and 10°C for about one hour.
 4. Measurement of each start point.
- This graph shows that both the micrometer and its standard must be left at the same location for at least several hours before adjusting the start point.

Hooke's Law

Hooke's law states that strain in an elastic material is proportional to the stress causing that strain, providing the strain remains within the elastic limit for that material.

Effect of Changing Support Method and Orientation

(Unit: µm)

The tables below show how the zero point changes due to differences in support orientation—such “Supported only at the center,” “Supported at the center in a lateral orientation,” and “Supported by hand downward”—after zero setting in the “Supported at the bottom and center” case. If the start point is not aligned using the same support method and orientation as the actual measurement, the values will change from the positions shown in the table below. Therefore, aligning the start point using the same support method and orientation as the measurement is recommended.

Supporting method	Supported at the bottom and center	Supported only at the center
Attitude		
Maximum measuring length (mm)		
325	0	-5.5
425	0	-2.5
525	0	-5.5
625	0	-11.0
725	0	-9.5
825	0	-18.0
925	0	-22.5
1025	0	-26.0

Supporting method	Supported at the center in a lateral orientation	Supported by hand downward
Attitude		
Maximum measuring length (mm)		
325	+1.5	-4.5
425	+2.0	-10.5
525	-4.5	-10.0
625	0.0	-5.5
725	-9.5	-19.0
825	-5.0	-35.0
925	-14.0	-27.0
1025	-5.0	-40.0

*Values are not guaranteed values but experimental values.

Abbe's Principle

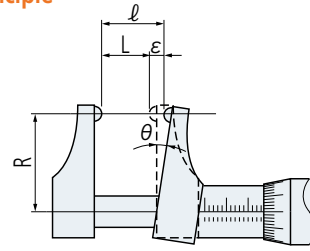

Abbe's principle states that “maximum accuracy is obtained when the scale and the measurement axes are common”. This is because any variation in the relative angle (θ) of the moving measuring jaw on an instrument, such as a caliper jaw micrometer, causes displacement that is not measured on the instrument's scale and this is an Abbe error ($\epsilon = \ell - L$ in the diagram). Spindle straightness error, play in the spindle guide or variation of measuring force can all cause (θ) to vary, and the error increases with R.

Hertz's Formula

Hertz's formula give the apparent reduction in diameter of spheres and cylinders due to elastic compression when measured between plane surfaces. The formula is useful for determining the deformation of a workpiece caused by the measuring force in point and line contact situations.

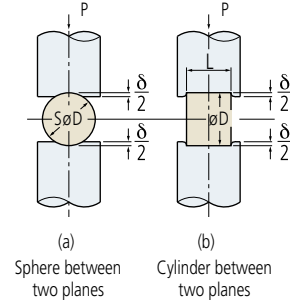

Assuming that the material is steel and units are as follows:
 Modulus of elasticity: $E = 205 \text{ GPa}$
 Amount of deformation: δ (µm)
 Diameter of sphere or cylinder: D (mm)
 Length of cylinder: L (mm)
 Measuring force: P (N)
 a) Apparent reduction in diameter of sphere
 $\delta_1 = 0.82 \sqrt[3]{P^2/D}$
 b) Apparent reduction in diameter of cylinder
 $\delta_2 = 0.094 \times (P/L)^{3/2} \sqrt{1/D}$

Major Measurement Errors of the Screw Micrometer

Error cause	Maximum possible error	Precautions for eliminating errors	Error that might not be eliminated even with precautions
Micrometer feed error	3 µm	1. Correct the micrometer before use.	±1 µm
Anvil angle error	±5 µm assuming the error of a half angle is 15 minutes	1. Measure the angle error and correct the micrometer. 2. Adjust the micrometer using the same thread gage as the workpiece.	±3 µm expected measurement error of half angle
Due to anvil difference	+10 µm		+3 µm
Influence of measuring force	±10 µm	1. Use a micrometer with a low measuring force if possible. 2. Always use the ratchet stop. 3. Adjust the micrometer using a thread gage with the same pitch.	+3 µm
Angle error of thread gage	±10 µm	1. Perform correction calculation (angle). 2. Correct the length error. 3. Adjust the micrometer using the same thread gage as the workpiece.	+3 µm
Length error of thread gage	±(3 + L/25) µm	1. Perform correction calculation. 2. Adjust the micrometer using the same thread gage as the workpiece.	±1 µm
Workpiece thread angle error	JIS 2 grade error of half angle ±229 minutes -91 µm +71 µm	1. Minimize the angle error as much as possible. 2. Measure the angle error and perform correction calculation. 3. Use the three-wire method for a large angle error.	Error of half angle ±8 µm at ±23 minutes
Cumulative error	(±117+40)µm	Aggregate value of possible errors	+26 µm -12 µm

Screw Pitch Diameter Measurement

Three-wire method

The screw pitch diameter can be measured with the three-wire method as shown in the figure.

Calculate the pitch diameter (E) with equations (1) and (2).

Metric thread or unified screw (60°)

$$E = M - 3d + 0.866025P \dots\dots (1)$$

Whitworth thread (55°)

$$E = M - 3.16568d + 0.960491P \dots (2)$$

- d = Wire diameter
- E = Screw pitch diameter
- M = Micrometer reading including three wires
- P = Screw pitch
(Convert inches to millimeters for unified screws.)

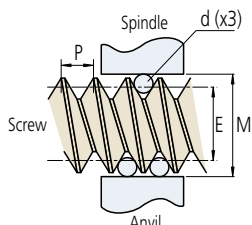

Thread type	Optimal wire size at D
Metric thread or unified screw (60°)	0.577P
Whitworth thread (55°)	0.564P

Major Measurement Errors of the Three-wire Method

Error cause	Precautions for eliminating errors	Possible error	Error that might not be eliminated even with precautions
Pitch error (Workpiece)	1. Correct the pitch error $\delta p = \delta E$ 2. Measure several points and adopt their average. 3. Reduce single pitch errors.	Pitch error $\pm 18 \mu\text{m}$ at 0.02 mm	$\pm 3 \mu\text{m}$
Error of half angle (Workpiece)	1. Use the optimal wire diameter. 2. No correction is needed.	$\pm 0.3 \mu\text{m}$	$\pm 0.3 \mu\text{m}$
Error due to anvil difference	1. Use the optimal wire diameter. 2. Use the wire which has a diameter close to the average at the one wire side.	$\pm 8 \mu\text{m}$	$\pm 1 \mu\text{m}$
Wire diameter error	1. Use the predetermined measuring force appropriate for the pitch. 2. Use the predetermined width of measurement edge. 3. Use a stable measuring force.	$-3 \mu\text{m}$	$-1 \mu\text{m}$
Cumulative error		In the worst case $+20 \mu\text{m}$ $-35 \mu\text{m}$	When measured carefully $+3 \mu\text{m}$ $-5 \mu\text{m}$

One-wire method

The pitch diameter of odd-fluted tap can be measured using the V-anvil micrometer with the one-wire method. Obtain the measured value (M₁) and calculate M with equation (3) or (4).

- M₁ = Micrometer reading during one-wire measurement
- D = Odd-fluted tap diameter

Tap with three flutes : $M = 3M_1 - 2D \dots\dots (3)$

Tap with five flutes : $M = 2.2360M_1 - 1.2360D \dots\dots (4)$

Then, assign the calculated M to equation (1) or (2) to calculate the pitch diameter (E).

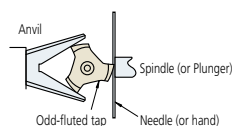

Root Tangent Length

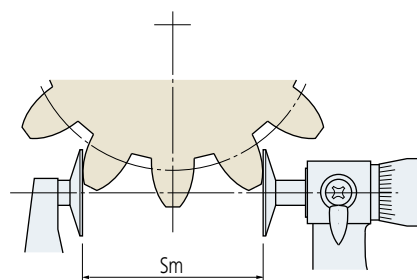

Formula for calculating a root tangent length (Sm):

$$Sm = m \cos \alpha_0 \{ \pi (Zm - 0.5) + Z \operatorname{inv} \alpha_0 \} + 2Xm \sin \alpha_0$$

Formula for calculating the number of teeth within the root tangent length (Zm):

$$Zm' = Z \cdot K (f) + 0.5 \quad (Zm \text{ is the integer closest to } Zm')$$

Here, $K(f) = \frac{1}{\pi} \{ \sec \alpha_0 \sqrt{(1 + 2f)^2 - \cos^2 \alpha_0} - \operatorname{inv} \alpha_0 - 2f \tan \alpha_0 \}$

However, $f = \frac{X}{Z}$

- m : Module
- α_0 : Pressure angle
- Z : Number of teeth
- X : Addendum modification coefficient
- Sm : Root tangent length
- Zm : Number of teeth within the root tangent length

$\operatorname{inv} 20^\circ = 0.014904$
$\operatorname{inv} 14.5^\circ = 0.0055448$

Gear Measurement

Over-pin method

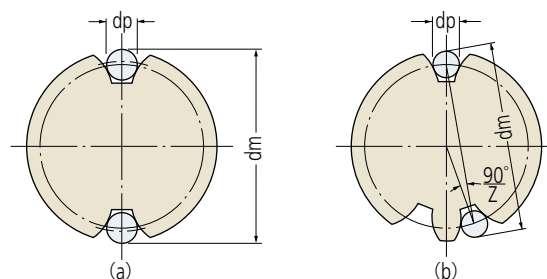

For a gear with an even number of teeth:

$$dm = dp + \frac{dg}{\cos \phi} = dp + \frac{z \cdot m \cdot \cos \alpha_0}{\cos \phi}$$

For a gear with an odd number of teeth:

$$dm = dp + \frac{dg}{\cos \phi} \cdot \cos \left(\frac{90^\circ}{z} \right) = dp + \frac{z \cdot m \cdot \cos \alpha_0}{\cos \phi} \cdot \cos \left(\frac{90^\circ}{z} \right)$$

However,

$$\operatorname{inv} \phi = \frac{dp}{dg} - \frac{X}{z} = \frac{dp}{z \cdot m \cdot \cos \alpha_0} - \left(\frac{\pi}{2z} - \operatorname{inv} \alpha_0 \right) + \frac{2 \tan \alpha_0}{z} \cdot X$$

Obtain ϕ (inv ϕ) from the involute function table.

- z : Number of teeth
- α_0 : Pressure angle teeth
- m : Module
- X : Addendum modification coefficient

Testing Parallelism of Micrometer Measuring Faces

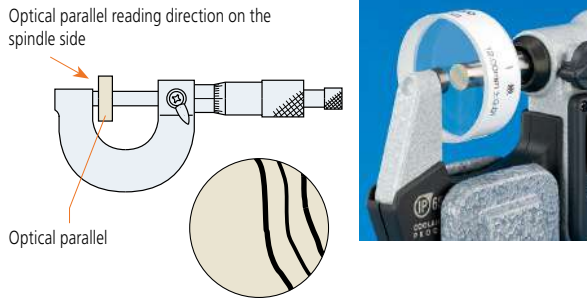

1. Wring the parallel to the anvil measuring face.
 2. Close the spindle on the parallel using standard measuring force and count the number of red interference fringes seen on the measuring face of the spindle in white light.
- In the above figure a parallelism of approximately $1\ \mu\text{m}$ is obtained from $0.32\ \mu\text{m} \times 3 = 0.96\ \mu\text{m}$.

Testing Flatness of Micrometer Measuring Faces

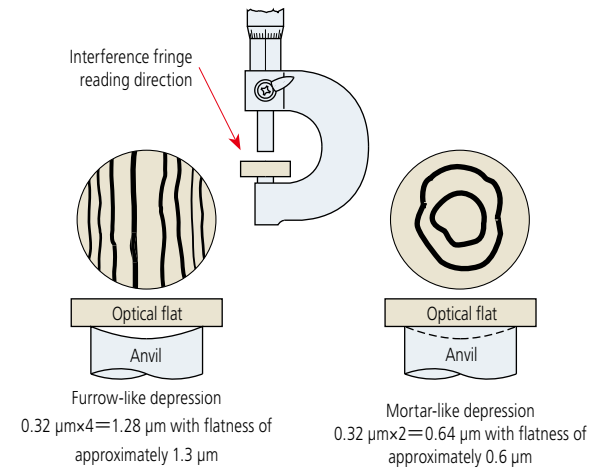

General Notes on Using the Micrometer

1. Carefully check the type, measuring range, accuracy, and other specifications to select the appropriate model for your application.
 2. Leave the micrometer and workpiece at room temperature long enough for their temperatures to equalize before making a measurement.
 3. Look directly at the fiducial line when taking a reading against the thimble graduations.
- If the graduation lines are viewed from an angle, the correct alignment position of the lines cannot be read due to parallax error.

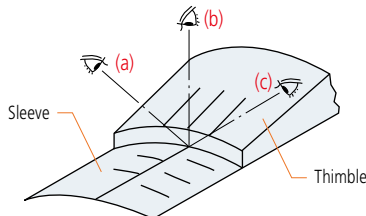

(a) From above the index line (b) Looking directly at the index line (c) From below the index line

4. Wipe off the measuring faces of both the anvil and spindle with lint-free paper set the start (zero) point before measuring.

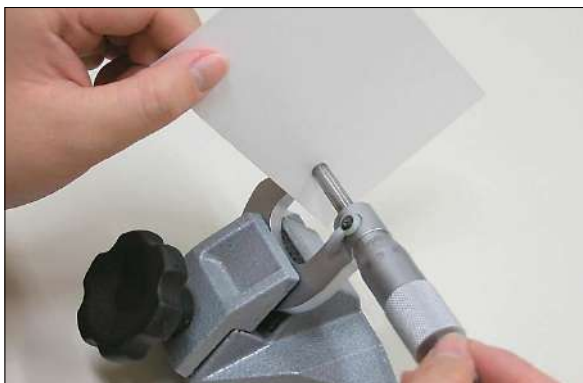

5. Wipe away any dust, chips and other debris from the circumference and measuring face of the spindle as part of daily maintenance. In addition, sufficiently wipe off any stains and fingerprints on each part with dry cloth.
6. Use the constant-force device correctly so that measurements are performed with the correct measuring force.
7. When attaching the micrometer onto a micrometer stand, the stand should clamp the center of the micrometer frame. Do not clamp with excessive force when attaching.

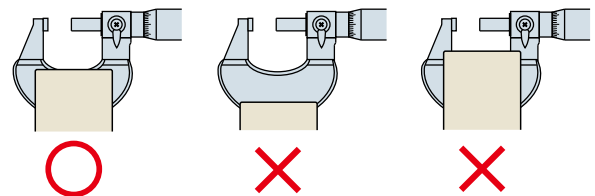

8. Be careful not to drop or bump the micrometer on anything. Do not rotate the micrometer thimble using excessive force.
9. After using the Micrometer for a long period of time or when there is no protective oil film visible, lightly apply anti-corrosion oil by wiping it with a cloth soaked with the oil.
10. Notes on storage:
 - Avoid storing the micrometer in direct sunlight.
 - Store the micrometer in a ventilated place with low humidity.
 - Store the micrometer in a place with little dust.
 - Store the micrometer in a case or other container, which should not be kept on the floor.
 - Store with the measuring faces open about 0.1 to 1 mm.
 - Do not store the micrometer in a clamped state.

Micrometer Performance

JIS B 7502 was revised and issued in 2016 as the Japanese Industrial Standards of the micrometer and "Industrial error" which indicates micrometer performance, was changed to "Indication error".

Full surface contact error is the most important micrometer indication error. The indication error is limited by the maximum permissible error (MPE). In other words, MPE has the same meaning as tolerance. The following describes the standard inspection method including the revised content of JIS 2016.

Maximum Permissible Error of Full Surface Contact Error J MPE [JIS B 7502: 2016]

The full surface contact error of the outside micrometer is an indication error measured by contacting the entire measuring surface with the object to be measured at an arbitrary point in the measuring range.

The full surface contact error can be obtained by adjusting the reference point using a constant pressure device with the minimum measuring length of the micrometer, inserting a grade 0 or 1 gauge block prescribed in JIS B 7506 or an equivalent or higher gauge between the measuring surfaces (Fig. 3), and then subtracting the dimensions of the gage block from the indication value of the micrometer using a constant pressure device.

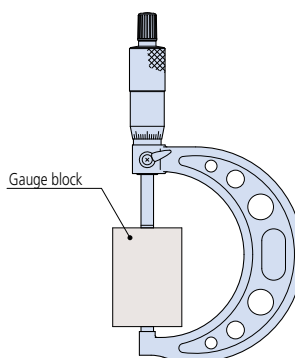

Fig: Measurement of full surface contact error

Micrometer Heads

Key Factors in Selection

Key factors in selecting a micrometer head are the measuring range, spindle face, stem, graduations, thimble diameter, etc.

Select the micrometer that best suits your purpose by referring to its particular characteristics.

Stem

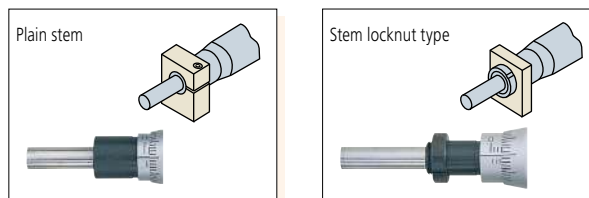

- The stem used to mount a micrometer head is classified as a "plain type" or "clamp nut type" as illustrated above. The stem diameter is manufactured to a nominal Metric or Imperial size with an h6 tolerance.
- The installations method have the following features:
 - Clamp nut stem: Allows fast and secure clamping of the linear gage head.
 - Plain stem: Wider range of application with positional adjustment in the axial direction on final installation, but requires a split-fixture clamping arrangement or adhesive fixing.
- General-purpose mounting fixtures are available as optional accessories.

Measuring Faces



- A flat measuring face is often specified where a micrometer head is used as a measurement tool.
- When a micrometer head is used as a feed device, a spherical face can minimize errors due to misalignment (Figure A). Alternatively, the flat face and spherical face can be reversed so that the spindle can bear against a sphere, such as a carbide ball (Figure B).
- A non-rotating spindle type micrometer head or one fitted with an antirotation device on the spindle (Figure C) can be used if a twisting action on the workpiece must be avoided.
- If a micrometer head is used as a stop, then a flat face both on the spindle and the face it contacts provides durability.

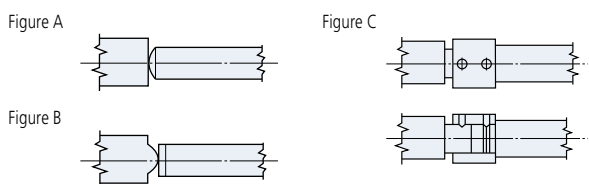

Non-Rotating Spindle

A non-rotating spindle type head does not exert a twisting action on a workpiece, which may be an important factor in some applications.

Spindle Thread Pitch

- The standard type head has a 0.5 mm pitch.
- 1 mm-pitch type:
 - Quicker to positioning, etc., than the standard type and avoids the possibility of a 0.5 mm reading error. Excellent load-bearing characteristics due to larger screw thread.
- 0.25 mm or 0.1 mm-pitch type
 - This type is the best for fine-feed or fine-positioning applications.

Constant-force Device

- A micrometer head fitted with a constant-force device (ratchet or friction thimble) is recommended for measurement applications.
- If using a micrometer head as a stop, or where saving space is a priority, a head without a ratchet is probably the best choice.



Micrometer head with constant-force device



Micrometer head without constant-force device (no ratchet)

Spindle Clamp

- When using a micrometer head as a stopper, problems caused by loosening can be prevented by using a micrometer head with a spindle clamp. The spindle clamp also prevents the spindle from changing position when the clamp is operated, providing the user with peace of mind.



Measuring Range (Stroke)

- When choosing a measuring range for a micrometer head, allow an adequate margin in consideration of the expected measurement stroke. Six stroke ranges, 5 mm to 50 mm, are available for standard micrometer heads.
- If a long stroke of over 50 mm is required, the concurrent use of a gauge block can extend the effective measuring range. (Figure D)

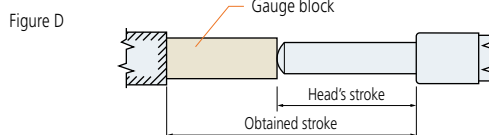

- In this guide, the range (or stroke end) of the thimble is indicated by a dashed line. Consider the thimble as moving within the range of the stroke ends to the position indicated by the line when designing the jig.

Ultra-fine Feed Applications

- Dedicated micrometer heads are available for manipulator applications, etc., which require ultra-fine feed or adjustment of spindle.

Thimble Diameter

- The diameter of a thimble greatly affects its usability and the "fineness" of positioning. A small-diameter thimble allows quick positioning whereas a large-diameter thimble allows fine positioning and easy reading of the graduations. Some models combine the advantages of both features by mounting a coarse-feed thimble (speeder) on the large-diameter thimble.



Graduation Styles

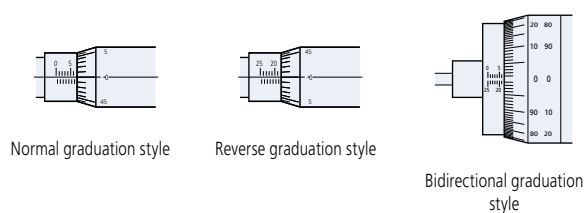

- Care is needed when taking a reading from a mechanical micrometer head, especially if the user is unfamiliar with the model.
- The "normal graduation" style, identical to that of an outside mounted micrometer, is the standard. For this style the reading increases as the spindle retracts into the body.
- On the contrary, in the "reverse graduation" style the reading increases as the spindle advances out of the body.
- The "bidirectional graduation style" is intended to facilitate measurement in either direction. The numbers are displayed in black and red in the respective directions for easy reading.
- Micrometer heads with a mechanical or electronic digital display, which allow direct reading of a measurement value, are also available. These types are free from misreading errors. A further advantage is that the electronic digital display type can enable computer-based storage and statistical processing of measurement data.

Guidelines for Self-made Fixtures

A micrometer head should be mounted by the stem. It must be mounted securely and precisely using a clamping method that does not exert excessive compression on the stem. There are three common mounting methods as shown below. Method (3) is not recommended. Adopt methods (1) or (2) wherever possible.

(Unit: mm)

Mounting method	(1) Clamp nut				(2) Split-body clamp				(3) Setscrew clamp			
	Points to keep in mind											
Stem diameter	ø9.5	ø10	ø12	ø18	ø9.5	ø10	ø12	ø18	ø9.5	ø10	ø12	ø18
Mounting hole	G7				G7				H5			
Fitting tolerance (mm)	+0.005 to +0.020		+0.006 to +0.024		+0.005 to +0.020		+0.006 to +0.024		0 to +0.006		0 to +0.008	
Precautions	Care should be taken to make Face A square to the mounting hole. The stem can be damped without any problem at squareness within 0.16/6.5.				Remove burrs generated on the wall of the mounting hole by the slitting operation.				M3x0.5 or M4x0.7 is an appropriate size for the setscrew. Limit countersinking into stem to 90°x0.5 and be careful not to damage the stem in the process.			

Custom-built Products (Product Example Introductions)

Micrometer heads have applications in many fields of science and industry and Mitutoyo offers a wide range of standard models to meet customers' needs. Mitutoyo can also custom build a head incorporating features better suited to your special application. Please feel free to contact Mitutoyo about the possibilities - even if only one custom-manufactured piece is required.

1. Spindle-end types

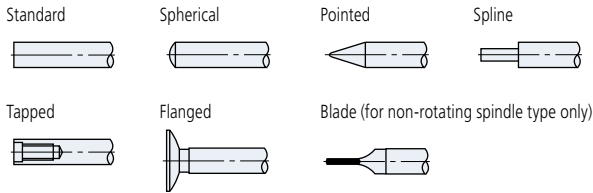

*A long spindle type is also available. Please consult Mitutoyo for details.

2. Stem types

A custom stem can be manufactured to suit the mounting fixture.

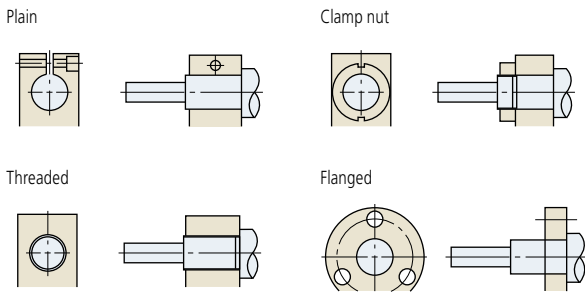

3. Scale graduation schemes

Various barrel and thimble scale graduation schemes, such as reverse and vertical, are available. Please consult Mitutoyo for ordering a custom scheme not shown here.

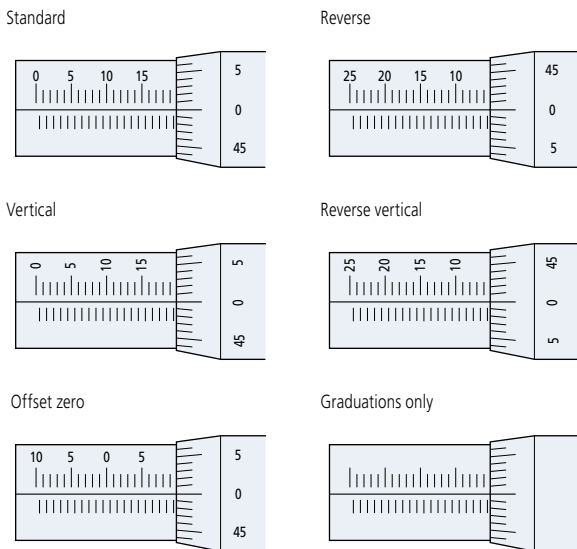

4. Logo engraving

A specific logo can be engraved as required.

5. Motor Coupling

Couplings for providing motor drive to a head can be designed.



6. Thimble mounting

Thimble mounting methods including a ratchet, setscrew, and hex-socket head screw are available.

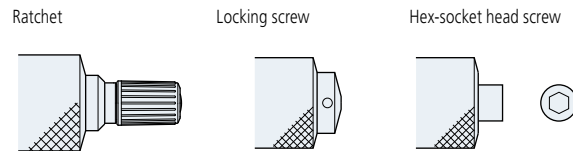

7. Spindle-thread pitch

Pitches of 1 mm for fast-feed applications or 0.25 mm and 0.1 mm for fine-feed can be supplied as alternatives to the standard 0.5 mm. Inch pitches are also supported. Please consult Mitutoyo for details.

8. Lubricant for spindle threads

Lubrication arrangements can be specified by the customer.

9. All-stainless construction

All components of a head can be manufactured in stainless steel.

10. Simple packaging

Large-quantity orders of micrometer heads can be delivered in simple packaging for OEM purposes.

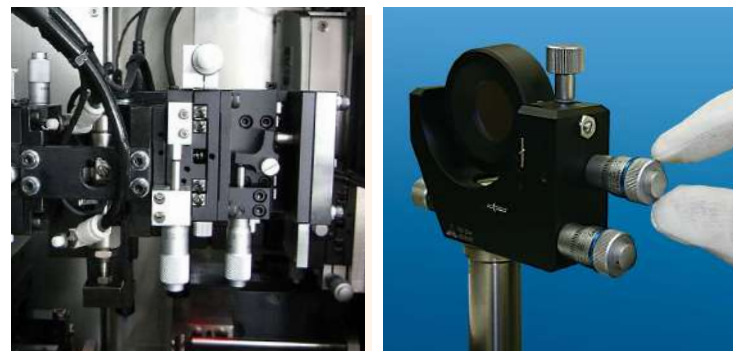

Maximum Loading Capacity of Micrometer Heads

The maximum loading capacity of a micrometer head depends mainly on the method of mounting. It also depends greatly on the conditions of usage, such whether the loading is static or dynamic or whether the head will be used as a stopper, for example. Therefore the maximum loading capacity of each model cannot be definitively specified. The loading limits recommended by Mitutoyo (at less than 100,000 revolutions if used for measuring within the guaranteed accuracy range) and the results of static load tests using a small micrometer head are given below.

1. Recommended maximum loading limit

		Maximum loading limit
Standard type	Spindle pitch: 0.5 mm	39.2 N ((4 kgf) *
	Spindle pitch: 0.1 mm/0.25 mm	19.6 N (2 kgf)
	Spindle pitch: 0.5 mm	39.2 N (4 kgf)
High-functionality type	Spindle pitch: 1.0 mm	58.8 N (6 kgf)
	Non-rotating spindle	19.6 N (2 kgf)
	MHF micro-fine feed type (with a differential mechanism)	

* Up to approx. 19.6 kgf only for MHT

2. Static load test for micrometer heads (using 148-104/148-103 for this test)

(Test method)

Micrometer heads were set up as shown and the force at which the head was damaged or pushed out of the fixture with a static load was applied in direction P.

(In the tests no account was taken of the guaranteed accuracy range.)

(1) Clamp nut

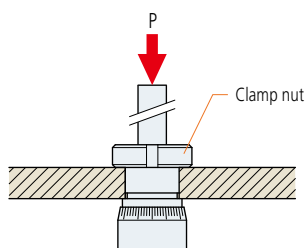

(2) Split-body clamp

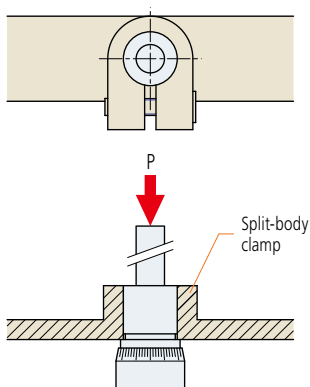

(3) Setscrew clamp

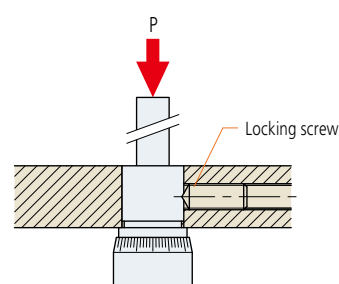

Mounting method	Damaging / dislodging load
(1) Clamp nut	Damage to the main unit will occur at 8.63 to 9.8 kN (880 to 1000 kgf).
(2) Split-body clamp	The main unit will be pushed out of the fixture at 0.69 to 0.98 kN (70 to 100 kgf).
(3) Setscrew clamp	Damage to the setscrew will occur at 0.69 to 1.08 kN (70 to 110 kgf).

Note: These load values should only be used as an approximate guide.

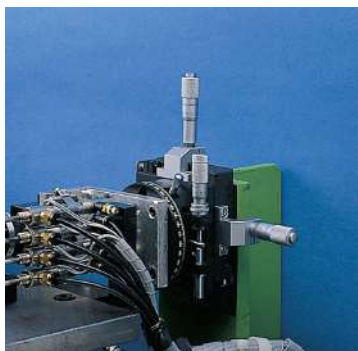
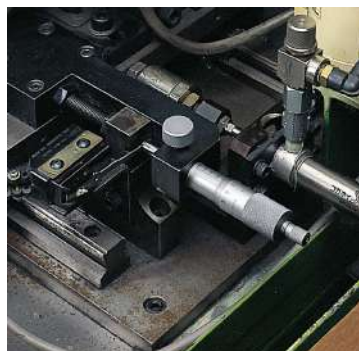

Inside Measuring Instruments

Nomenclature (Holtest)

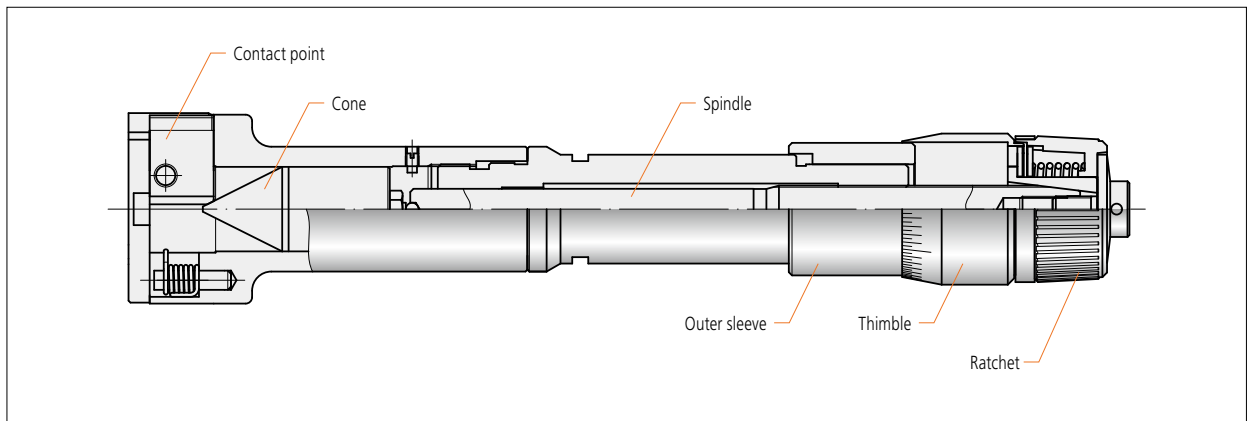

Taking Readings

Graduation 0.005 mm

(1) Outer sleeve reading:	35 mm
(2) Thimble reading:	0.015 mm
Holtest reading:	35.015 mm

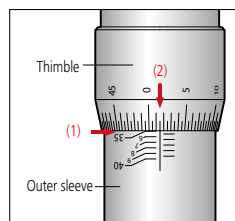

Changes in Measured Values at Different Measuring Points

When Holtest is used, the measured value differs between measurement across the anvil and the measurement only at the tip of the anvil due to the product mechanism. Adjust the start point under the same condition before measurement.

When you use the tip of the anvil for measurement, adjust the start point for using the tip of the anvil.

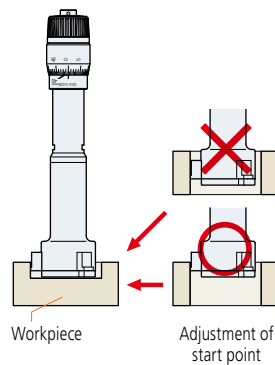

Measurement Error Due to Inside Micrometer Temperature Change

Temperature changes cause measuring tools to produce errors in measurement. When making a measurement by holding an inside micrometer directly in the hand, it is necessary to prevent expansion of the micrometer due to body temperature by holding the thermally insulating plate with gloves, etc.

Effect of Misalignment on Accuracy (Inside Micrometer)

Figure 1

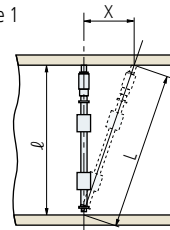
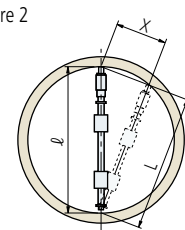
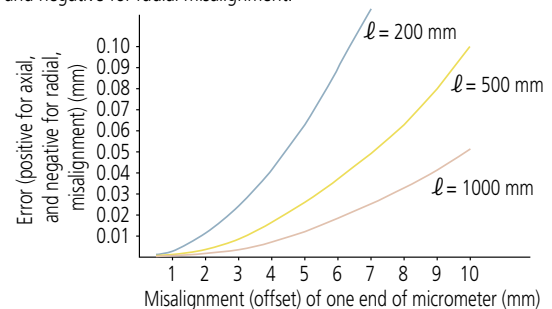

Figure 2



- l : Inside diameter to be measured
 - L : Length measured with axial offset X
 - X : Offset in axial direction
 - Δl : Error in measurement
 - $\Delta l : L - l = \sqrt{l^2 + X^2} - l$
- l : Inside diameter to be measured
 - L : Length measured with axial offset X
 - X : Offset in axial direction
 - Δl : Error in measurement
 - $\Delta l : L - l = \sqrt{l^2 - X^2} - l$

If the Inside Micrometer is misaligned in the axial or radial direction by an offset distance X when a measurement is taken, as in Figures 1 and 2, then that measurement will be in error as shown in the graph below (constructed from the formula given above). The error is positive for axial misalignment and negative for radial misalignment.



Airy and Bessel Points

When a length standard bar or inside micrometer lies horizontally, supported as simply as possible at two points, it bends under its own weight into a shape that depends on the spacing of those points.

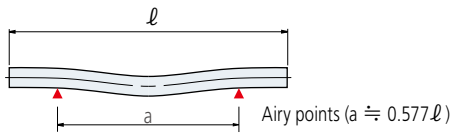

The ends of a bar (or micrometer) can be made exactly horizontal by spacing the two supports symmetrically as shown above.

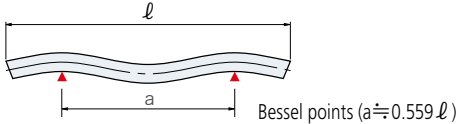

The change in length of a bar (or micrometer) due to bending can be minimized by spacing the two supports symmetrically as shown above.

Reference Point Setting (2-point Gages)

Conduct reference point setting with a ring gage or cylinder master gage. Insert the bore gage into the ring gage, vertically or horizontally swing the bore gage, and set the point where the indicator reads the maximum value as the reference point.

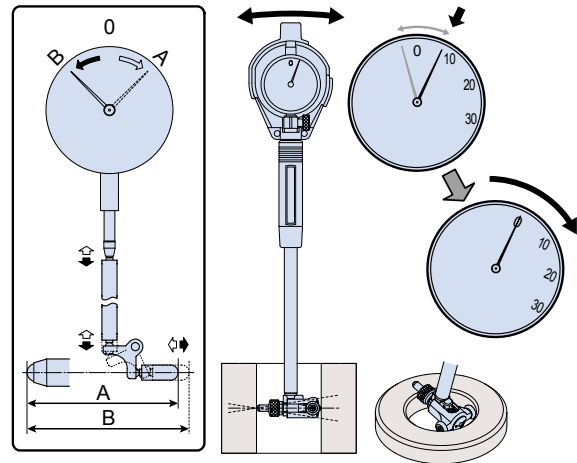

Custom-ordered Products (Holtest / Borematic)

Mitutoyo can custom-build an inside micrometer best suited to your special application. Please feel free to contact Mitutoyo about the possibilities - even if only one custom-manufactured piece is required. Please note that, depending on circumstances, such a micrometer will usually need to be used with a master setting ring for accuracy assurance. (A custom-ordered micrometer can be made compatible with a master ring supplied by the customer. Please consult Mitutoyo.)

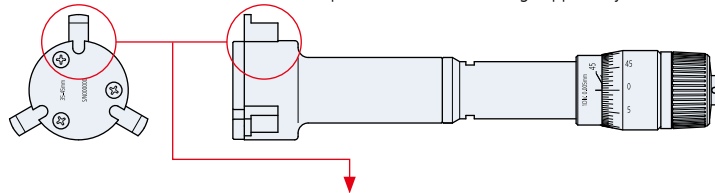

Type	Workpiece profile (example)	Contact point tip profile (example)	Remarks
Square groove		Tip radius R that can measure the minimum diameter (different for each size). W=1 or more.	<ul style="list-style-type: none"> Can measure the diameter of variously shaped inside grooves and splines. Minimum measurable groove diameter: Approximately 16 mm (differs depending on the workpiece profile.) Dimension l should be as follows: For W = less than 2 mm: l = less than 2 mm For W = 2 mm or more: l = 2 mm as the standard value which can be modified according to circumstances. The number of splines or serrations is limited to a multiple of 3. Details of the workpiece profile should be provided at the time of placing a custom-order. If your application needs a measuring range different from that of the standard inside micrometer an additional initial cost for the master ring gage will be required.
Round groove		Tip radius R that can measure the minimum diameter (different for each size). W=1 or more, R=0.5 or more.	
Spline		W=0.5 or more. Tip radius R that can measure the minimum diameter (different for each size).	
Serration		45° or more. R=0.3 or more.	
Screw			

*Mitutoyo will manufacture products to accommodate other applications.
 *Prices, delivery times, and other details will vary depending on the nature and content of the special order.
 *Please contact your nearest Mitutoyo sales office for orders.

Calipers

Nomenclature

Vernier Caliper

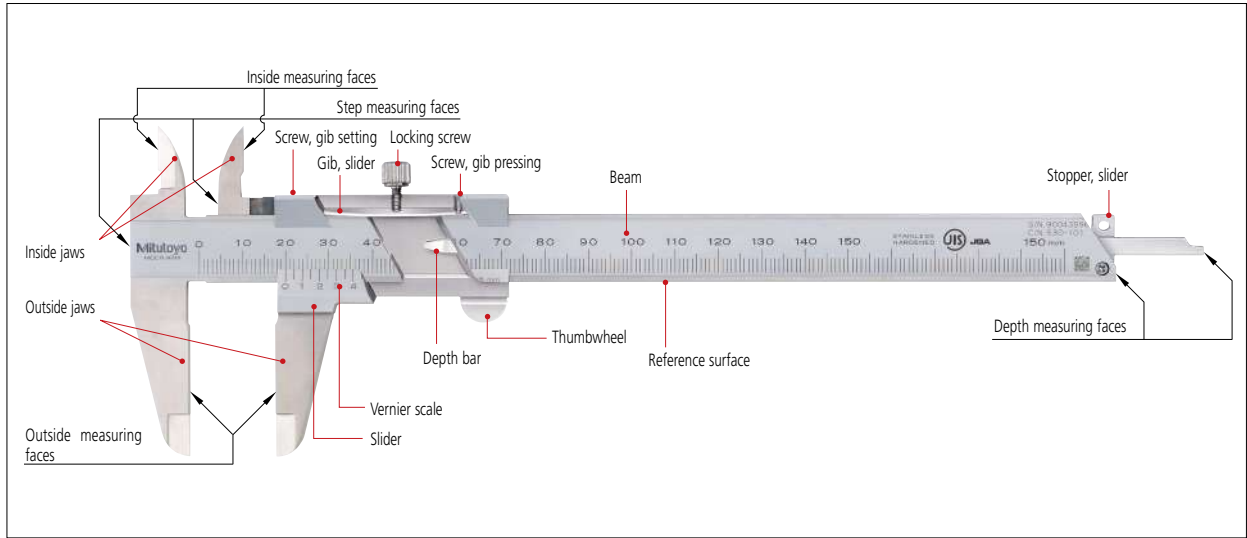

Absolute Digimatic Caliper

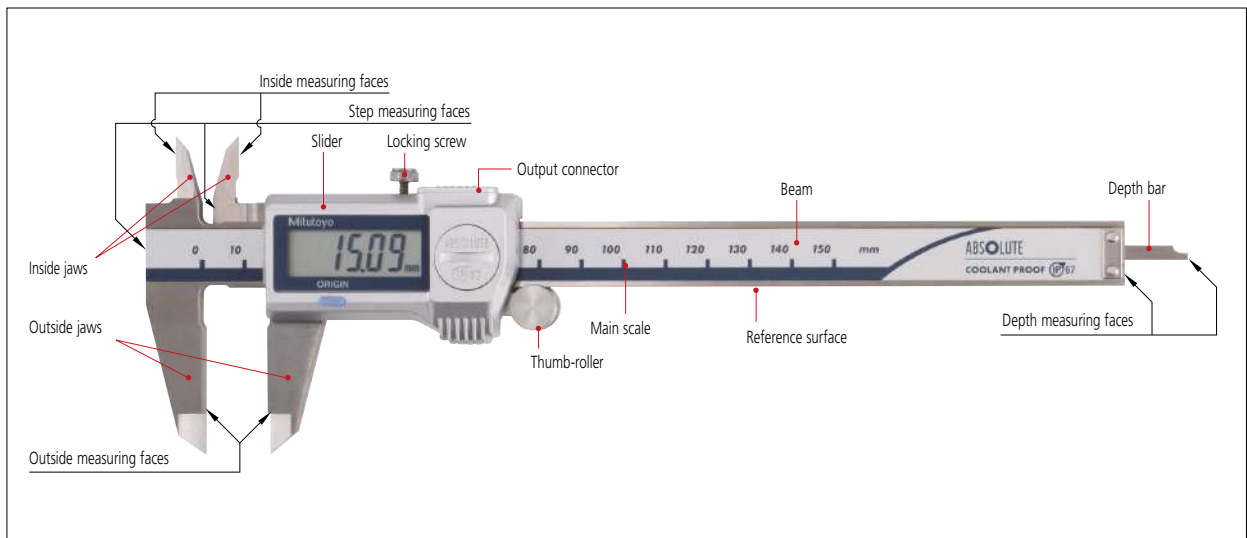

Taking Readings

Calipers

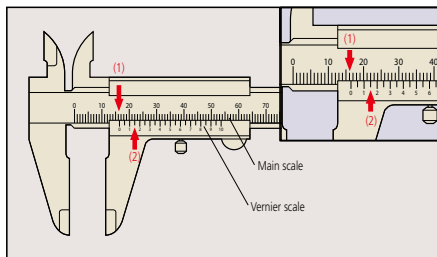

Minimum reading: 0.05 mm

(1) Main scale reading: 16 mm
 (2) Vernier scale reading: 0.15 mm

Calipers reading: 16.15 mm

Dial Calipers

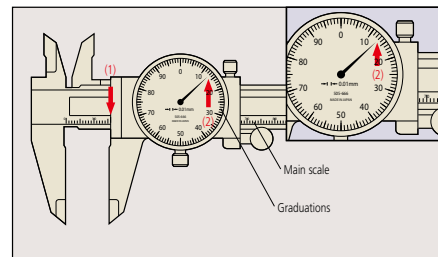

Minimum reading: 0.01 mm

(1) Main scale reading: 16 mm
 (2) Graduations reading: 0.13 mm

Dial calipers reading: 16.13 mm

Note: Above left, 0.15 mm (2) is read at the position where a main scale graduation line corresponds with a vernier graduation line.

Measurement Examples

Outside measurement

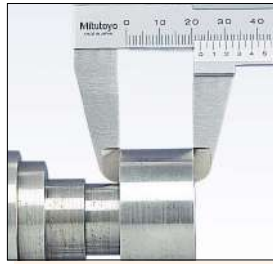

Inside measurement

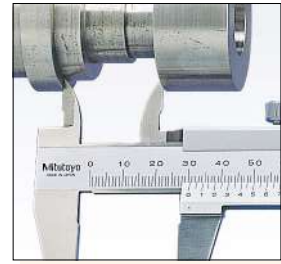
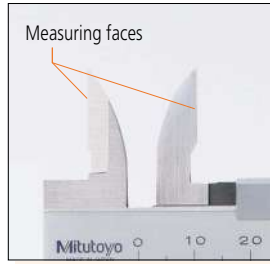

Step measurement

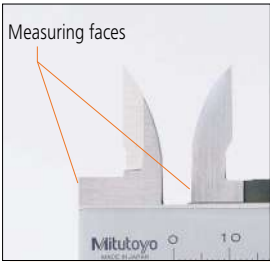

Depth measurement

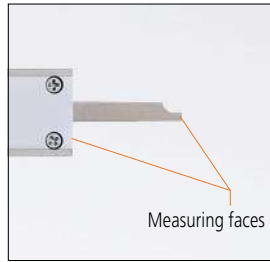

Special Purpose Caliper Applications

For uneven surface measurement

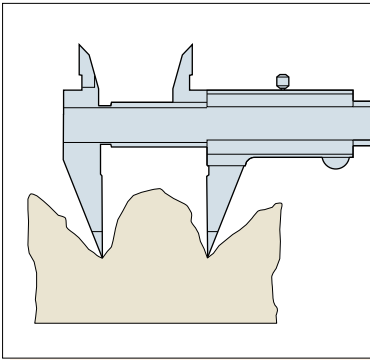

Point jaw type

For stepped feature measurement

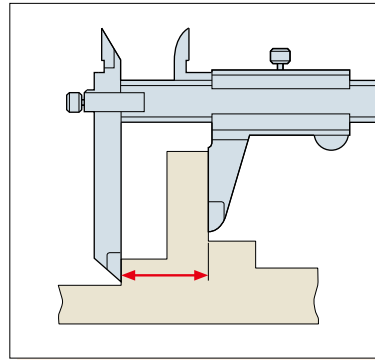

Offset jaw type

For depth measurement

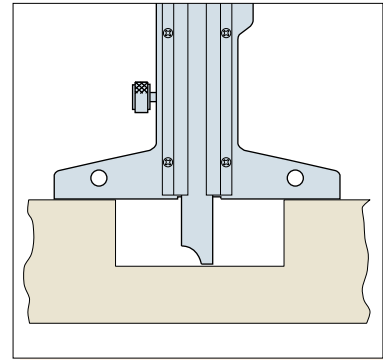

Depth type

For diameter of narrow groove measurement

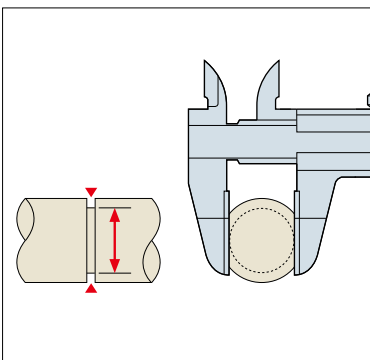

Blade jaw type

Ordinary outside measurement
For inside diameter of stepped hole measurement

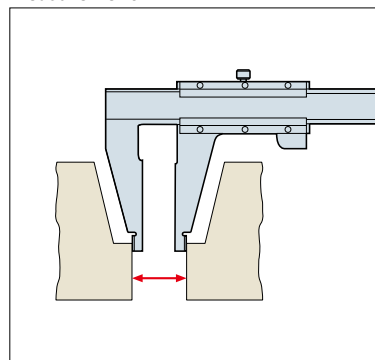

Neck-type calipers

Ordinary outside measurement
For stepped hole measurement

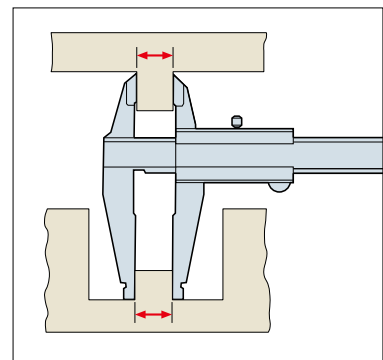

Tube thickness-type calipers

Vernier Scale

This is a short auxiliary scale that enables accurate interpolation between the divisions of a longer scale without using mechanical magnification. Specifically, n divisions on a vernier scale are the same length as $n-1$ divisions on the main scale it works with, and n defines the division (or interpolation) ratio. The example below is for $n = 10$.

The main scale is graduated in mm, and so the vernier scale is 9 mm (10 divisions) long, the same as 9 mm (9 divisions) on the main scale. This produces a difference in length of 0.1 mm (1) as shown in figure A (the 1st vernier graduation is aligned with the first main scale graduation). If the vernier scale is slid 0.1 mm to the right as shown in figure B, the 2nd graduation line on the vernier scale moves into alignment with the 2nd line on the main scale (2), and so enables easy reading of the 0.1 mm displacement.

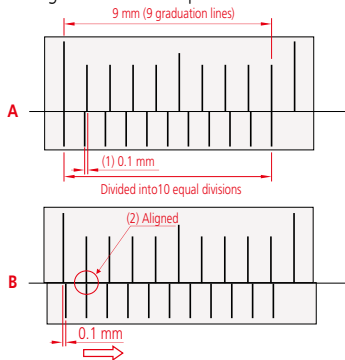

Some early calipers divided 19 divisions on the main scale by 20 vernier divisions to provide 0.05 mm resolution. However, the closely spaced lines proved difficult to read and so, since the 1970s, a long vernier scale that uses 39 main scale divisions to spread the lines is generally used instead, as shown below.

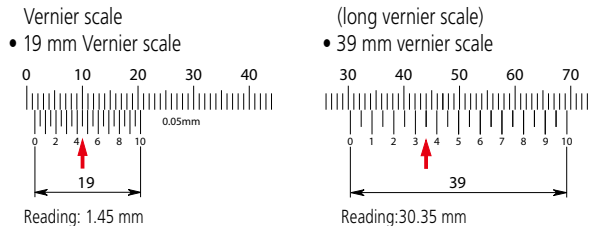

Calipers were made that gave an even finer resolution of 0.02 mm. These required a 49-division vernier scale dividing 50 main scale divisions. However, they were difficult to read and are now hard to find since Digital calipers with an easily read display and resolution of 0.01 mm appeared.

About Long Calipers

Steel rules are commonly used when measuring to a limited accuracy. Long Calipers are used for further accuracy than a Steel Rule, but less than a Micrometer. A long caliper is very convenient for its user friendliness but does require some care in use.

- Minimum reading and indication error differ (see Mitutoyo's catalog values for details)
- Pay attention to how the calipers are supported, as measurement errors due to deflection tend to occur.
- When using the inside measuring faces, pay attention to measuring force as the faces are furthest away from the reference surface.
- When using a long-jaw caliper, pay attention to measuring force even when using the outside measuring faces.

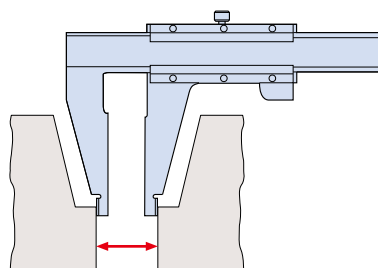

Small Hole Measurement with an M-type Caliper

A structural error d occurs when you measure the internal diameter of a small hole.

● True internal diameter (ϕD : 5 mm)
Unit mm

t_1+t_2+C	0.3	0.5	0.7
Δd	0.009	0.026	0.047

ϕD : True internal diameter

ϕd : Measured diameter

t_1, t_2 : Thickness of the inside jaw

C : Distance between the inside jaws

Δd : Measurement error ($\phi D - \phi d$)

$$\phi D - \phi d$$

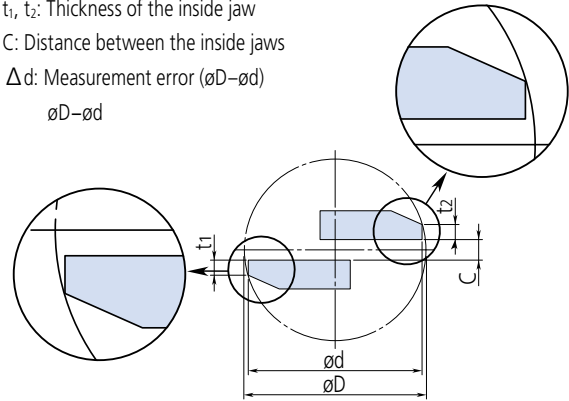

Inside Measurement with a CM-type Caliper

Because the inside measuring faces of a CM-type caliper are at the tips of the jaws, attention must be given to measuring force. Additionally, the parallelism of the measuring faces and step differences of the jaws are problematic. The radius of curvature of the measuring faces must be less than 1/2 of the combined dimensions of the inside measurement section. In contrast to an M-type caliper, a CM-type caliper cannot measure small holes below the combined measurement size. Mitutoyo CM-type calipers are provided with an extra scale on the slider for inside measurements so they can be read directly without the need for calculation. The elimination of calculations reduces measurement errors.

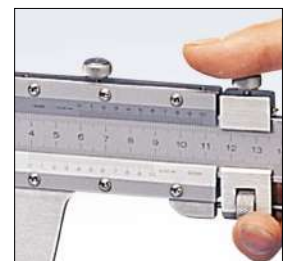
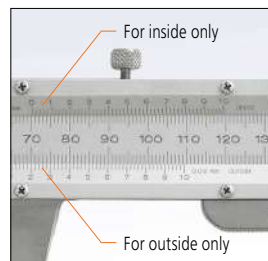

General Notes on Use of Caliper

1. Potential causes of error

The main factors behind caliper errors are:

- Excessive measuring force
- Differential thermal expansion due to a temperature difference between the caliper and workpiece
- Effect of the thickness of the knife-edge jaws and the clearance between these jaws during measurement of the diameter of a small hole
- Graduation accuracy
- Reference edge straightness
- Main scale flatness on the beam
- Squareness of the jaws

There is no problem with the caliper if these error factors are within the indication error.

Handling notes have been added to the JIS so that consumers can appreciate the error factors caused by the structure of the caliper before use. These notes relate to the measuring force and stipulate that "as the caliper does not have a constant-force device, you must measure a workpiece with an appropriate even measuring force.

Take extra care when you measure it with the root or tip of the jaw because a large error could occur in such cases."

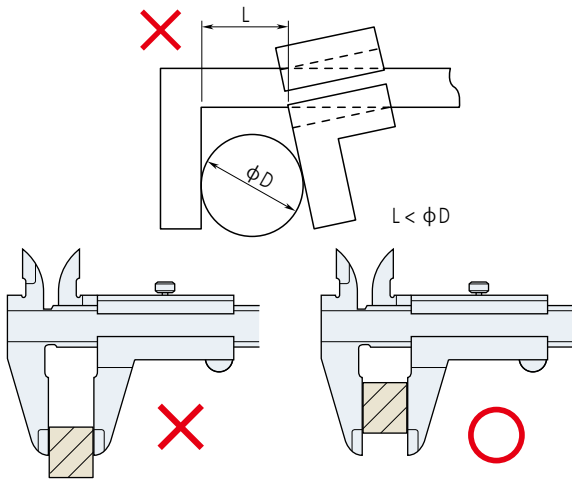

2. Inside measurement

Insert the inside jaw as deeply as possible before measurement.
Read the maximum indicated value during inside measurement.
Read the minimum indicated value during groove width measurement.

3. Depth measurement

Read the minimum indicated value during depth measurement.

4. Parallax error when reading the scales

Look straight at the vernier graduation line when checking the alignment of vernier graduation lines to the main scale graduation lines.

If you look at a vernier graduation line from an oblique direction, a parallax effect is caused by the difference between the tip of the vernier scale and the main scale. Consequently, the matching position appears to be off by ΔX as shown in the figure below, resulting in a reading error of the measured value. To avoid this error, the JIS stipulates that the step height should be no more than 0.3 mm.

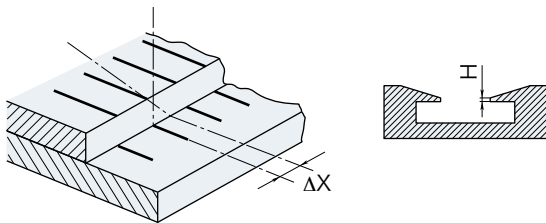

5. Moving Jaw Tilt Error

The guide face provides the basis for the caliper's slider. Consequently, measurement errors result when the face becomes warped, as shown in the figure. This error can be represented by the same calculation formula for errors caused by nonconformance to Abbe's Principle.

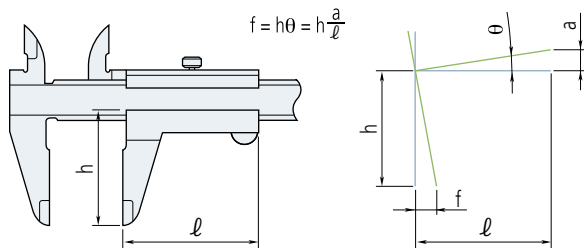

Example: Assume that the error slope of the jaws due to tilt of the slider is 0.01 mm in 50 mm and the outside measuring jaws are 40 mm deep, then the error (at the jaw tip) is calculated as $(40/50) \times 0.01 \text{ mm} = 0.008 \text{ mm}$.

$$f = 40 \text{ mm} \times 0.01 \div 50 = 0.008 \text{ mm}$$

The effects of a guide face that is worn or deformed because it was handled carelessly cannot be ignored.

6. Relationship between accuracy and temperature

The main scale of a caliper is engraved (or mounted on) stainless steel, and although the linear thermal expansion coefficient is equal to that of the most common workpiece material, steel, i.e. $(10.2 \pm 1) \times 10^{-6} / \text{K}$, note that other workpiece materials, the room temperature and the workpiece temperature may affect measurement accuracy.

7. Handling

Caliper jaws are sharp, and therefore the instrument must be handled with care to avoid personal injury.

Avoid damaging the scale of a digital caliper and do not engrave an identification number or other information on it with an electric marker pen. Avoid damaging a caliper by subjecting it to impact with hard objects or by dropping it on a bench or the floor.

8. Maintenance of beam sliding surfaces and measuring faces

Wipe away dust and dirt from the sliding surfaces and measuring faces with a dry soft cloth before using the caliper.

9. Checking and setting the origin before use

Close the jaws and ensure that the vernier scale (or display) reads zero before using the caliper.

When using a Digimatic caliper, reset the origin (ORIGIN button) after replacing the battery.

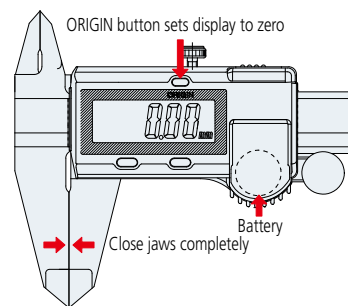

10. Handling after use

After using the caliper, completely wipe off any water and oil and lightly apply anti-corrosion oil before storage.

Wipe off water from a waterproof caliper as well because it may also rust.

11. Notes on storage:

Avoid direct sunlight, high temperatures, low temperatures, and high humidity during storage.

If a digital caliper will not be used for more than three months, remove the battery before storage.

Do not leave the jaws of a caliper completely closed during storage.

Caliper Performance

Caliper performance specified in the Japanese Industrial Standard JIS B 7507 for calipers was revised in 2016 (JIS B 7507: 2016) to JIS B 7507: 2016: The term "instrumental error" that was used until 1993 was changed to "indication error."

Partial surface contact error is the most important caliper indication error. The indication error is limited by the maximum permissible error (MPE). In other words, MPE has the same meaning as tolerance.

The following describes the standard inspection method including the revised content of JIS 2016.

Maximum Permissible Error E_{MPE} of Partial Measuring Surface Contact Error in a Conventional Caliper [JIS B 7507:2016]

The partial measuring surface contact error of a caliper is an indication error applied to the outside measurement.

Table 1 shows the Maximum Permissible Error E_{MPE} of the indication value of the partial measuring surface contact error.

The maximum permissible error E_{MPE} of an inside measurement can be obtained by measuring the inside dimensions using the inside measuring faces at any position within the measuring range using gauge blocks or an equivalent or higher gauge (**Fig. 1**) and subtracting the gauge dimension from the indicated value of the caliper.

Table 1: Maximum permissible error E_{MPE} of partial measuring face contact of conventional calipers

(Unit: mm)

Measurement length	Scale interval, graduation or resolution	
	0.05	0.02
50 or less	± 0.05	± 0.02
Over 50, 100 or less	± 0.06	± 0.03
Over 100, 200 or less	± 0.07	
Over 200, 300 or less	± 0.08	± 0.04

Note: E_{MPE} includes the measurement error arising from the straightness, flatness and parallelism of the measuring surface.

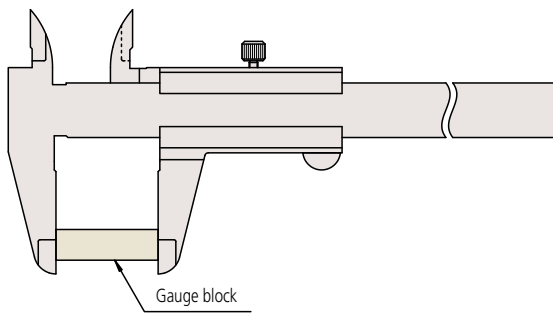

Fig. 1: Determining of partial measuring surface contact error (example)

Maximum Permissible Error of Scale Shift Error S_{MPE} [JIS B 7507: 2016]

The scale shift error in a caliper is an indication error of the inside measurement, depth measurement, etc., if measuring surfaces other than the outside measuring surfaces are used.

The Maximum Permissible Error S_{MPE} of the indication value for inside measurement is given in **Table 1**. The Maximum Permissible Error S_{MPE} of depth measurement is obtained by adding 0.02 mm to a value in **Table 1**. The maximum permissible error S_{MPE} of an inside measurement can be obtained by measuring the inside dimensions using the inside measuring faces at any position within the measuring range using gauge blocks or an equivalent or higher gauge (**Fig. 2**) and subtracting the gauge dimension from the indicated value of the caliper.

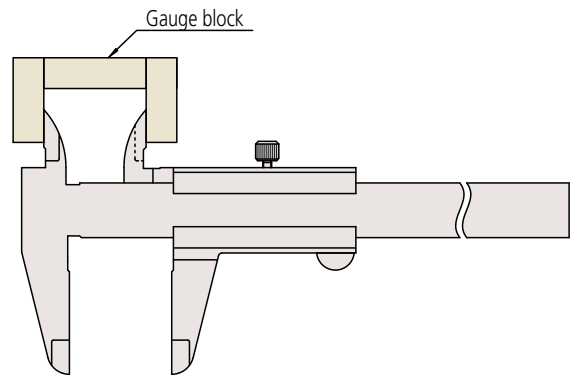

Fig. 2: Determining inside measurement indication error (example)

Partial Surface Contact Error E
[ISO 13385-1:2019, JIS B 7507:2022]

The partial surface contact error of a caliper is an indication error applied to outside measurement.

The ISO-2019 standard quantifies for each measuring range the testing method and criteria, such as test points, number of tests, and testing arrangement that were previously left to the manufacturers' own criteria. (Fig. 1, Table 1)

Fig. 1

Ex.) For a caliper with a measuring range of 150 mm, the revised standard requires five or more test points.

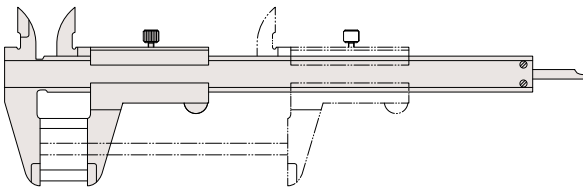

Table 1: Number of partial surface contact error test points

Measuring range (mm)	Minimum number of test points
150	5
300	6
1000	7
1,000 or more	8

Furthermore, the revised standards require testing in 90% or more points within the product measuring range as well as testing at the root and tip of the jaw at the maximum/minimum point. Therefore, it is important to conduct tests following the newly defined standard.

The following is an example of measurement for a 150 mm caliper. To comply with the ISO 13358-1:2019 standard, the minimum number of test points is five for a 150 mm caliper (Fig. 1).

Five or more test points are necessary to comply with the ISO 13385-1:2019 and JIS B7507:2022 standards. These include testing at the maximum and minimum point, as well as at the root and tip of the measuring unit. These test points must add up to a total of five.

Shift Error S

The Shift Error for calipers is the error of indication for areas other than the outside measuring face.

In ISO13385-1:2019 and JIS B 7507:2022, all measurement errors other than outside measurement errors (inside, depth, step, and I.D. measurement error) are shift errors. Test points and their number were newly quantified as the type of errors included in the Scale Shift Error were better specified.

(Fig. 2, 3, Table 2)

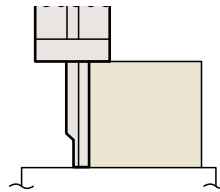

Table 2
Ex.) Step and depth measurement

[ISO 13385-1:2019]		
Test numbering	Test point	Reference standard
1	Less than 50 mm	Gauge block

Figure 2: Scale Shift Error measurement example-depth measurement

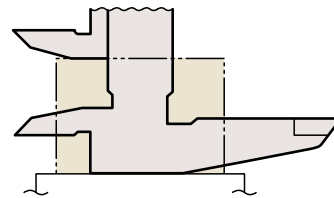

Figure 3: Scale Shift Error measurement example-step measurement

For depth measurement or step measurement, the standard specifically requires one or more test points at less than 50 mm and a testing arrangement using gauge blocks among other items.

(See Table 3)

Responses to ISO 13385-1:2019 and JIS B 7507:2022

The ISO standard for calipers, ISO 13385-1, was revised and published as ISO 13385-1:2019 in August 2019. Additionally, the Japanese Industrial Standard JIS B 7507 for calipers was revised based on ISO 13385-1:2019, and published as JIS B 7507:2022 in May 2022. The major point of these revisions is that they specifically quantify the notation and the inspection methods, etc., related to caliper accuracy. This quantification does not affect the quality of calipers manufactured in the past, as they were measured and inspected in a standardized way in line with certain methods and criteria.

Height Gages

Nomenclature

Vernier Height Gage

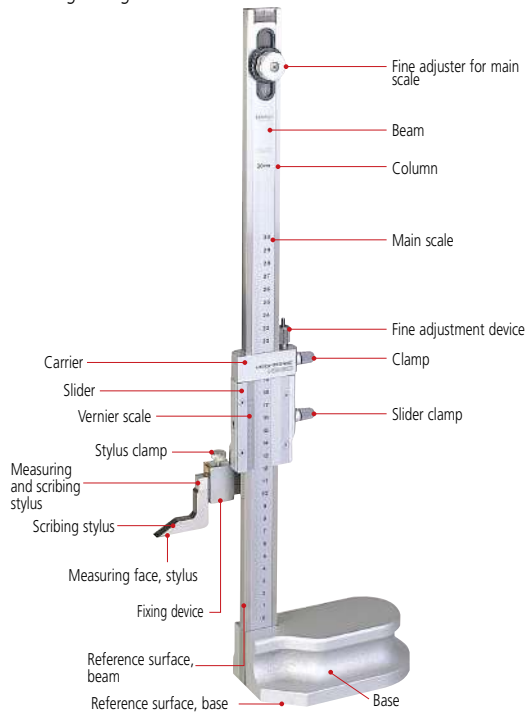

Mechanical Digit Height Gage

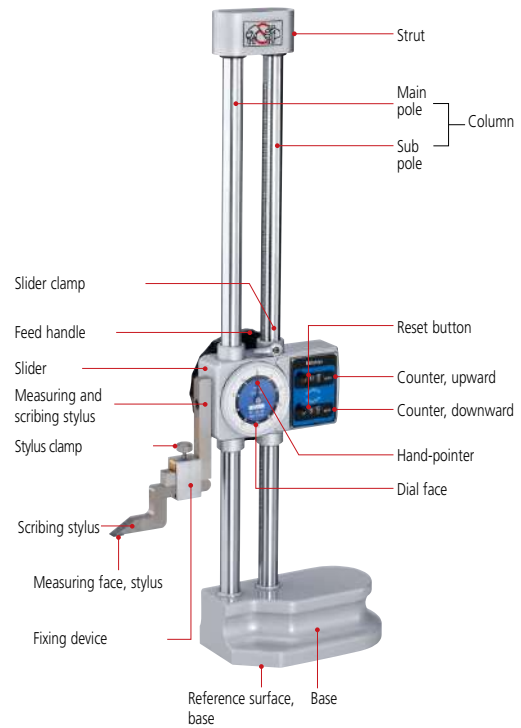

Digital Height Gages

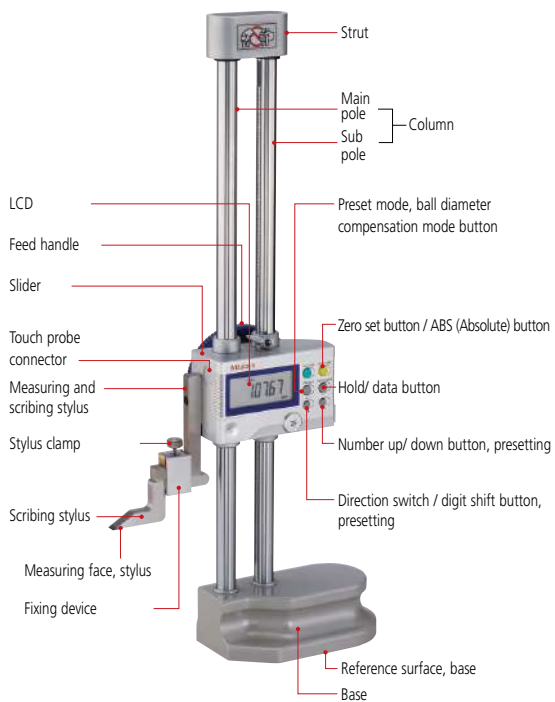

Height Gage Applications with Optional Accessories and Other Measuring Tools



Test indicator attachment



Touch probe attachment



Center probe attachment



Depth gage attachment

Taking Readings

Vernier Height Gage

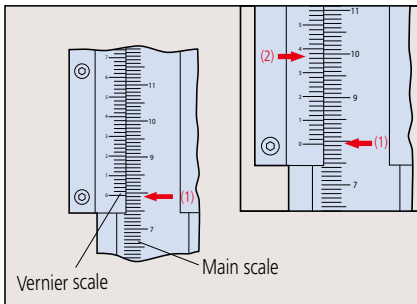

Minimum reading: 0.02 mm

(1) Main scale reading:	79 mm
(2) Vernier scale reading:	0.36 mm
Vernier height gage reading: 79.36 mm	

Mechanical Digit Height Gage

Measuring upwards from a reference surface

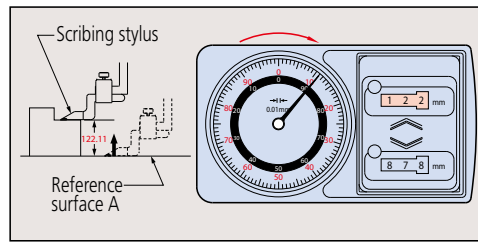

(1) Counter reading:	122 mm
(2) Graduations reading:	0.11 mm

Mechanical digit height gage reading: 122.11 mm

Measuring downwards from a reference surface

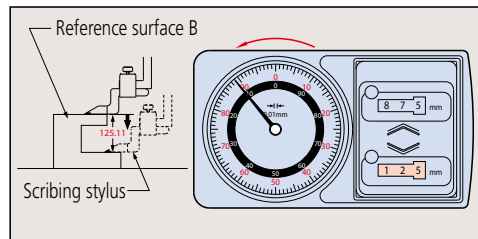

(1) Counter reading:	125 mm
(2) Graduations reading:	0.11 mm

Mechanical digit height gage reading: 125.11 mm

General Notes on Use of Height Gages

1. Potential causes of error

Given that this height gage is a measuring instrument that does not conform to Abbe's principle, the following error factors are possible.

- Parallax error
- Excessive measuring force
- Differential thermal expansion due to a temperature difference with the workpiece
- Structure of the height gage.

In particular, structure and error factors related to a "reference edge warping" and "scraper installation" described below should be fully understood before use.

2. Reference edge (column) warping and scriber installation

As shown in the following figure, measurement errors result when using the height gage if the reference column, which guides the slider, becomes warped. This error can be represented by the same calculation formula for errors caused by nonconformance to Abbe's Principle.

Here, installing the scriber (or a lever-type dial indicator) requires careful consideration because it affects the size of any error due to a warped reference column by increasing dimension h in the above formula. Specifically, pay attention to the following when installing the scriber.

- Make sure that the dimension h in the following formula is not too large.
- Install the scriber, etc., so that it does not protrude too far forward from the main body.

Be careful when using an optional long scriber or lever-type dial indicator, as the error factor will grow larger.

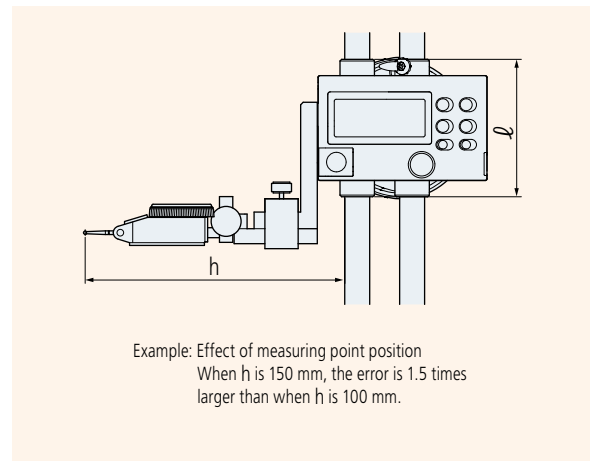
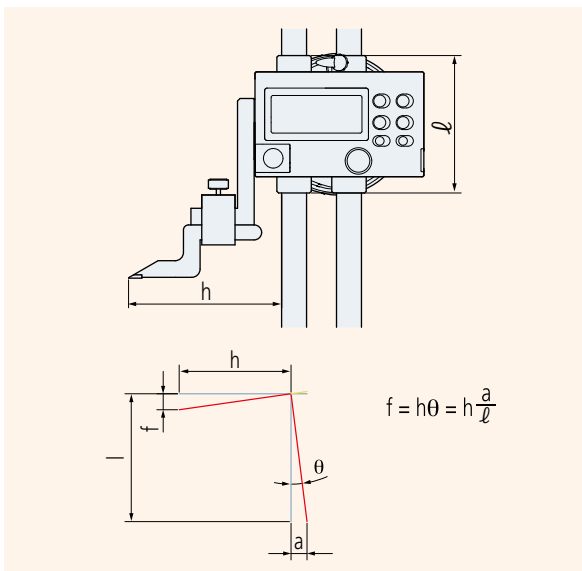

3. Lifting of the base from the reference surface

The height gage's slider can be moved with the driving handle and adjuster. After the slider contacts the workpiece, the base may lift from the surface plate if excessive downwards force is used on the slider (measuring force is applied). This results in measurement error.

For accurate setting, move the slider slowly downwards until the scriber is just felt to lightly touch the workpiece.

Always make certain that the surface plate and height gage base reference surface are free of dust or burrs.

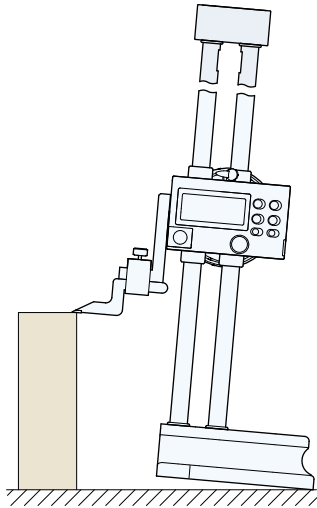

4. Error due to inclination of the main scale (column)

According to JIS standards, the perpendicularity of the column reference edge to the base reference surface should be better than

$$\left(0.01 + \frac{L}{1000}\right) \text{ mm} \quad L \text{ indicates the measuring length (unit: mm)}$$

This is not a very onerous specification. For example, the perpendicularity limit allowable is 0.61 mm when L is 600 mm.

This is because this error factor has a small influence and does not change the inclination of the slider, unlike a warped column.

5. Relationship between accuracy and temperature

Height gages are made of several materials. Note that some combinations of workpiece material, room temperature, and workpiece temperature may affect measuring accuracy if this effect is not allowed for by performing a correction calculation.

6. A height gauge scriber tip is very sharp. Handle with care to avoid any personal injury.
7. Do not damage a digital height gage scale by engraving an identification number or other information on it with an electric marker pen.
8. Carefully handle a height gage so as not to drop it or bump it against anything.

Notes on Using the Height Gage

1. Keep the column, which guides the slider, clean. If dust or dirt accumulates on it, sliding becomes difficult, leading to errors in setting and measuring.
2. When scribing, securely lock the slider in position using the clamping arrangements provided.
It is advisable to confirm the setting after clamping because the act of clamping on some height gages can alter the setting slightly. If this is so, allowance must be made when setting to allow for this effect.
3. Parallelism between the scriber measuring face and the base reference surface should be 0.01 mm or better.
Check that there are no dust or burrs on the mounting surface when installing the scriber or lever-type dial indicator before measurement. Keep the scriber and other parts securely fixed in place during measurement.
4. If the main scale of the height gage can be moved, move it as required to set the zero point, and securely tighten the fixing nuts.
5. Because of parallax errors, always look at the scale from the front when taking readings.

6. Handling after use

Completely wipe off any water and oil and lightly apply anti-corrosion oil before storage.

7. Notes on storage:

- Avoid direct sunlight, high temperatures, low temperatures, and high humidity during storage.
- If a digital height gage will not be used for more than three months, remove the battery before storage.
- If a protective cover is provided, use the cover during storage to prevent dust from adhering to the column.

Height Gage Performance

JIS B 7517 was revised and issued in 2018 as the Japanese Industrial Standards for height gage, and the "Instrumental error" indicating the performance of a height gage was changed to "Indication error."

Height measurement error is the most important height gage indication error. The indication error is limited by the maximum permissible error (MPE). In other words, MPE has the same meaning as tolerance.

The following describes the standard inspection method including the revised content of JIS 2018.

Maximum Permissible Error of Height Measurement E_{MPE}
 [JIS B 7517: 2018]

The height measurement error in a height gage is the indication error when the reference edge (column) is perpendicular to the base reference surface and the direction of contact is downward.

Table 1 shows the maximum permissible height measurement error E_{MPE} . The maximum permissible error E_{MPE} for a height measurement can be obtained by measuring a gauge block, or equivalent, with a height gage on a precision surface plate (Fig. 1) and then subtracting the gauge block size from the measured size.

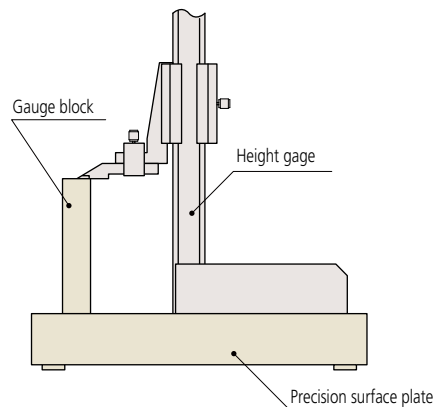

Fig. 1: Determination of height measurement error

Table 1: Maximum permissible height measurement error E_{MPE} of a conventional height gage

(Unit: mm)

Measurement length	Scale interval, graduation or resolution	
	0.05	0.02 or 0.01
50 or less	± 0.05	± 0.02
Over 50, 100 or less	± 0.06	± 0.03
Over 100, 200 or less	± 0.07	
Over 200, 300 or less	± 0.08	± 0.04
Over 300, 400 or less	± 0.09	
Over 400, 500 or less	± 0.10	± 0.05
Over 500, 600 or less	± 0.11	
Over 600, 700 or less	± 0.12	± 0.06
Over 700, 800 or less	± 0.13	
Over 800, 900 or less	± 0.14	± 0.07
Over 900, 1000 or less	± 0.15	

Note: E_{MPE} includes the measurement error arising from straightness, flatness of the measuring surface and parallelism with the reference surface.

Depth Gages

Depth Gage Performance

JIS B 7518 was revised and issued in 2018 as the Japanese Industrial Standards for depth gage, and the “Instrumental error” indicating the performance of a depth gage was changed to “Indication error.” Partial surface contact error is the most important depth gage indication error. The indication error is limited by the maximum permissible error (MPE). In other words, MPE has the same meaning as tolerance. The following describes the standard inspection method including the revised content of JIS 2018.

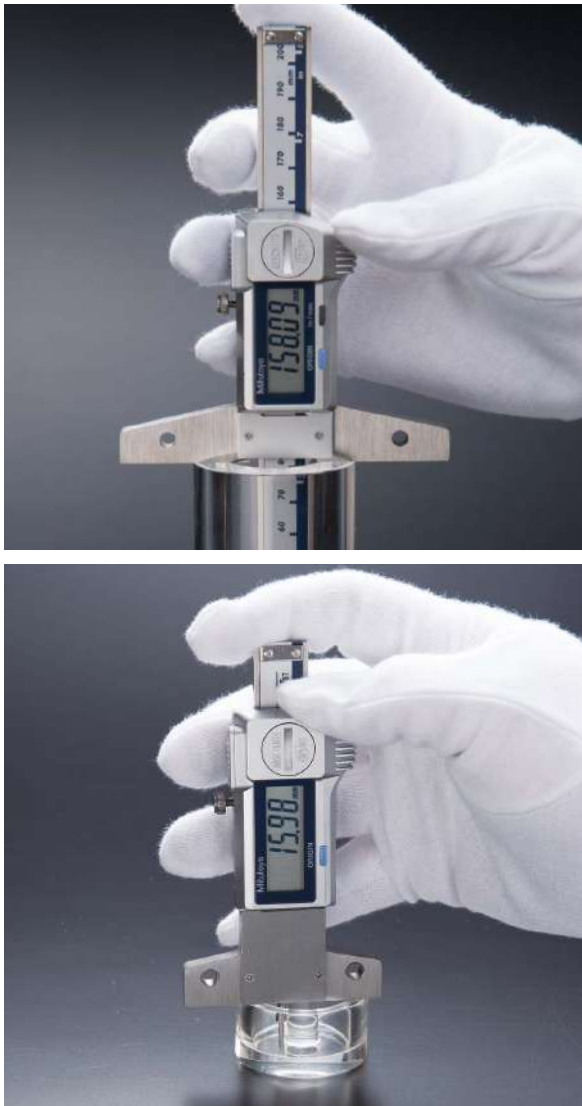

Maximum Permissible Error of Depth Measurement E_{MPE} [JIS B 7518: 2018]

The Maximum Permissible Error E_{MPE} of a depth gage is an indication error applied to depth measurement.

Table 1 shows the Maximum Permissible Error E_{MPE} of the indication value of the partial measuring surface contact error.

The maximum permissible error E_{MPE} for a depth measurement can be obtained by measuring the height of two equal length gauge blocks, or equivalent, with a height gage on a precision surface plate (Fig. 1) and then subtracting the gauge block size from the measured size.

Table 1: Maximum permissible error E_{MPE} of partial measuring face contact of a conventional depth gage

(Unit: mm)

Measurement length	Scale interval, graduation or resolution	
	0.05	0.02 or 0.01
50 or less	± 0.05	± 0.02
Over 50, 100 or less	± 0.06	± 0.03
Over 100, 200 or less	± 0.07	
Over 200, 300 or less	± 0.08	± 0.04
Over 300, 400 or less	± 0.09	
Over 400, 500 or less	± 0.10	± 0.05
Over 500, 600 or less	± 0.11	

Note: E_{MPE} includes the measurement error arising from straightness, flatness of the measuring surface and parallelism with the reference surface.

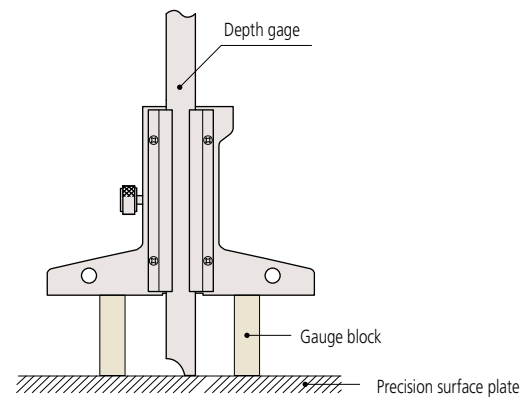

Fig. 1: Measurement of partial measuring surface contact error

Gauge Blocks

Select Gauge Blocks to be Combined to Make Up the Size Required for the Stack.

- (1) Selection, preparation and assembly of a gauge block stack
Select gauge blocks with consideration for the following points:
 - a. Use the minimum number of blocks whenever possible.
 - b. Select thick gauge blocks whenever possible.
 - c. Select the size from the one that has the least significant digit required, and then work back through the more significant digits.

Example: For 23.456 mm



Example: For 25.435 mm

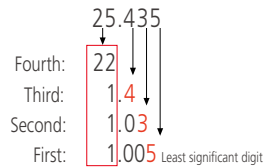

- (2) Clean the gauge blocks with an appropriate cleaning agent.
- (3) Check the measuring faces for burrs. When inspecting for burrs, use an optical flat as follows:

Fig. 1

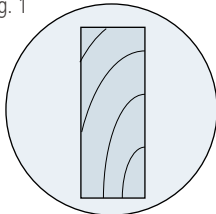
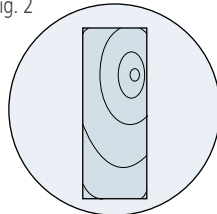

Fig. 2



- a. Wipe each measuring face clean.
- b. Gently place the optical flat on the gauge block measuring face.
- c. Lightly slide the optical flat to check that the interference fringes disappear. (Fig. 1, Fig. 2)
Judgment 1: If no interference fringes appear, it is assumed that there is a large burr or contaminant on the measuring face.
- d. Lightly press the optical flat to check that the interference fringes disappear.
Judgment 2: If the interference fringes disappear, no burr exists on the measuring face.
Judgment 3: If some interference fringes remain locally while the flat is gently moved to and fro, a burr exists on the measuring face. If the fringes move along with the optical flat, there is a burr on the optical flat.
- e. Remove burrs by referring to the figures.

Fig. 3

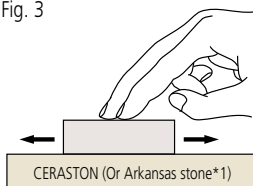
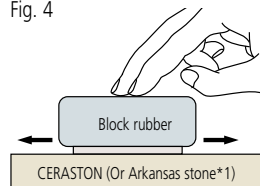

Fig. 4



- (1) Wipe any dust and oil films from the gauge block and the Ceraston (or Arkansas stone)^{*1} using a solvent.
- (2) Place the gauge block on the Ceraston (or Arkansas stone)^{*1} so that the measuring face that has burrs is on the abrasive surface of the stone. While applying light pressure, move the gauge block to and fro about ten times (Fig. 3).
For thin gauge blocks, use a block rubber that makes it easy to apply even pressure (Fig. 4).
- (3) Check the measuring face for burrs with an optical flat.
If the burrs have not been removed, repeat step (2). If burrs are too large, they may not be removed with an abrasive stone. Replacement with a new gauge block is recommended when burrs cannot be removed.

*1 Mitutoyo does not offer Arkansas stones.

- (4) Apply a very small amount of oil to the measuring face and spread it evenly across the face. Wipe the face until the oil film is almost entirely removed. Use grease, spindle oil, Vaseline, or other recommended oils.
- (5) Gently overlay the faces of the gauge blocks to be wrung together.
There are three methods to use (a, b and c as shown below) according to the size of blocks being wrung:

a. Wringing thick gauge blocks

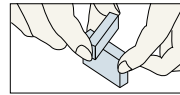

Cross the gauge blocks at 90° in the middle of the measuring faces.

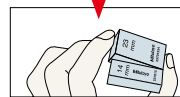

Rotate the gauge blocks while applying slight force to them. Slide the gauge block to check for a feeling of adhesion.

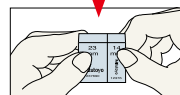

Align the measuring faces with each other.

b. Wringing a thick gauge block to a thin gauge block

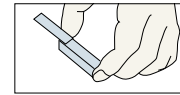

Overlap one side of a thin gauge block on one side of a thick gauge block.

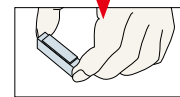

Slide the thin gauge block while pressing the entire overlapped area to align the measuring faces with each other.

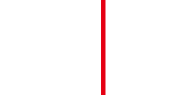

Finally, remove the thick gauge block from the stack.

c. Wringing thin gauge blocks

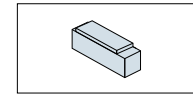

To prevent thin gauge blocks from bending, first wring a thin gauge block onto a thick gauge block.

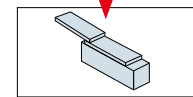

Then, wring the other thin gauge block onto the first thin gauge block.

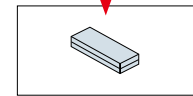

Finally, remove the thick gauge block from the stack.

Apply an optical flat to the surface of one thin gauge block to check the wringing state.

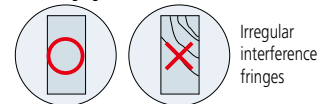

Irregular interference fringes

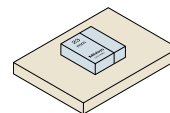

Wipe the exposed measuring face(s) and continue building up the stack, in the same manner as above, until complete.

Definition of the Meter

The 17th General Conference of Weights and Measures in 1983 decided on a new definition of the meter unit as the length of the path traveled by light in a vacuum during a time interval of 1/299 792 458 of a second. The gauge block is the practical realization of this unit and as such is used widely throughout industry.

Dial Indicators, Digital Indicators and Test Indicators

Nomenclature

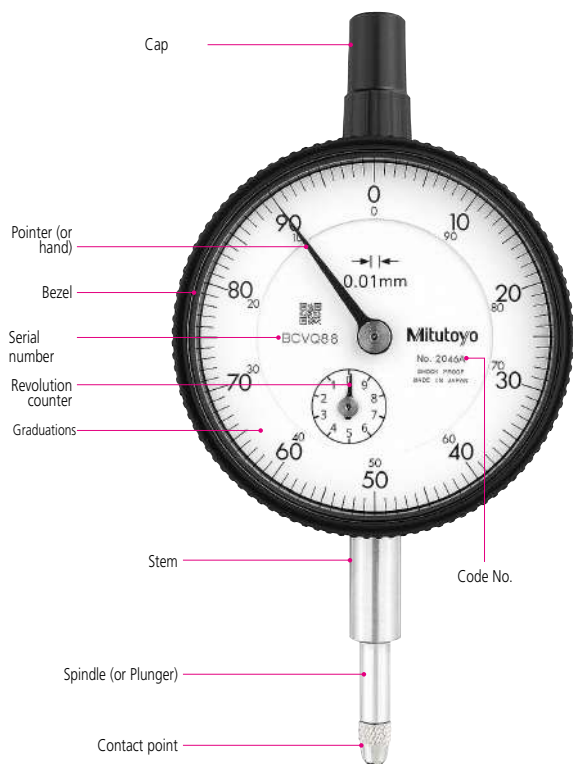

Setting the origin of a digital indicator

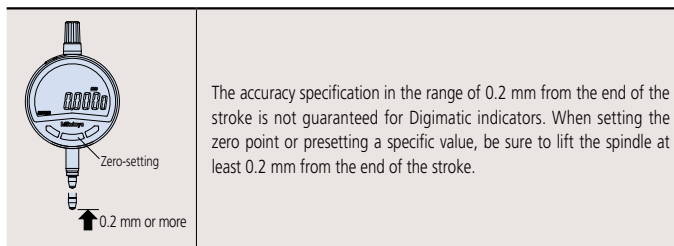

Care of the spindle

- Do not lubricate the spindle. Doing so might cause dust to accumulate, resulting in a malfunction.
- If the spindle movement is poor, wipe the upper and lower spindle surfaces with a dry or alcohol-soaked cloth. If the movement is not improved by cleaning, contact Mitutoyo for repair.
- Before making a measurement or calibration, confirm that the spindle moves smoothly by moving it upward and downward and check the stability of the zero point.

Dial Indicator and Digital Indicator Mounting

Stem mounting	Method	Clamping the stem directly with a screw 	Clamping the stem by split-clamp fastening
	Precautions	<ul style="list-style-type: none"> • Mounting hole tolerance: $\varnothing 8G7 (+0.005 \text{ to } 0.02)$ • Clamping screw: M4 to M6 • Clamping position: 8 mm or more from the lower edge of the stem • Maximum clamping torque: 150 N-cm when clamping with a single M5 screw • Note that excessive clamping torque may adversely affect spindle movement. 	<ul style="list-style-type: none"> • Mounting hole tolerance: $\varnothing 8G7 (+0.005 \text{ to } 0.02)$
Lug mounting	Method		
	Note	<ul style="list-style-type: none"> • Lugs can be changed 90° in orientation according to the application. (The lug is set horizontally when shipped.) • Lugs of some Series 1 models (No. 1911A-10, 1913A-10 and 1003A), however, cannot be altered to horizontal. • Fix the spindle so that it is perpendicular to the measuring face. A large inclination may cause measurement error. 	

Contact Point

- Screw thread is standardized on M2.5 x 0.45 (Length: 5 mm).
- Incomplete thread section at the root of the screw shall be less than 0.7 mm when fabricating a contact point.

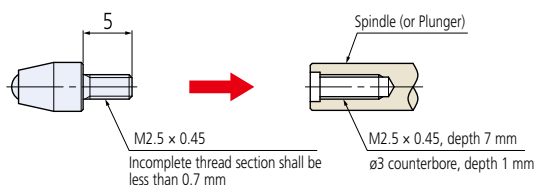

Measuring Orientation

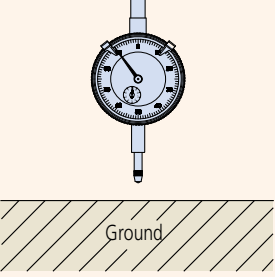
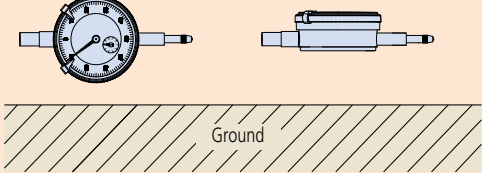
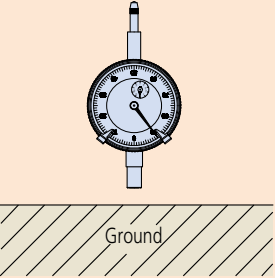
	Attitude	Remarks
Vertical position (contact point downward)		-
Lateral position (spindle horizontal)		
Upside-down position (contact point upward)		<p>If measurement is performed in the lateral orientation, or upside-down orientation, the measuring force is less than in the vertical orientation. In this case be sure to check the operation and repeatability of the indicator. For guaranteed-operation specifications according to the operating orientation refer to the specific product descriptions in the catalog.</p>

Maximum permissible error

Unit: μm

		Maximum permissible error (MPE) by measurement characteristics -- dial indicators with bezel dia. 50 mm or larger								Maximum permissible error (MPE) by measurement characteristics --dial indicators with bezel dia. 50 mm or smaller and Back Plunger type dial indicators													
Graduation (mm)		0.01								0.005	0.001		0.01								0.005	0.002	0.001
Measuring range (mm)		1 or less	Over 1 and up to 3	Over 3 and up to 5	Over 5 and up to 10	Over 10 and up to 20	Over 20 and up to 30	Over 30 and up to 50	Over 50 and up to 100	5 or less	1 or less	Over 1 and up to 2	Over 2 and up to 5	1 or less	Over 1 and up to 3	Over 3 and up to 5	Over 5 and up to 10	5 or less	1 or less	1 or less			
Retrace error		3	3	3	3	5	7	8	9	3	2	2	3	4	4	4	5	3.5	2.5	2			
Repeatability		3	3	3	3	4	5	5	5	3	0.5	0.5	1	3	3	3	3	3	1	1			
Indication error	Arbitrary 1/10 revolution	5	5	5	5	8	10	10	12	5	2	2	3.5	8	8	8	9	6	2.5	2.5			
	Arbitrary 1/2 revolution	8	8	9	9	10	12	12	17	9	3.5	4	5	11	11	12	12	9	4.5	4			
	One revolution	8	9	10	10	15	15	15	20	10	4	5	6	12	12	14	14	10	5	4.5			
	Entire measuring range	8	10	12	15	25	30	40	50	12	5	7	10	15	16	18	20	12	6	5			

Note 1: The maximum permissible error (MPE) for one-revolution dial indicators does not specify the indication error of an arbitrary 1/2 and 1 revolution.

Note 2: The MPE represents the value at 20 °C, which JIS B 0680 defines as the standard temperature.

Note 3: If the manufacturer has not specified dial indicator's measurement characteristics, the indicator must meet both maximum permissible error (MPE) and measurement force permissible limits (MPL) at any position within the measuring range in any posture.

Dial Indicator Standard B7503 : 2017 (Extract from JIS/Japanese Industrial Standards)

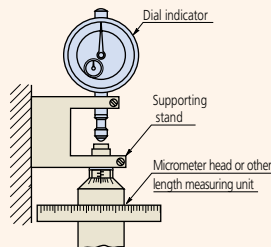
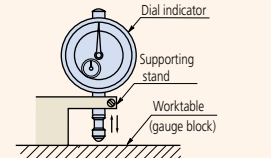
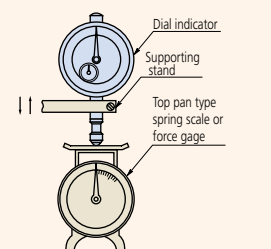
Item	Model	Measuring method (zero-point fixed)	Evaluation method (performance evaluation by moving the zero point)	Measurement examples	
Indication error	Indication error over the entire measuring range	One-revolution dial indicator and multi-revolution dial indicator	Obtain the difference between the maximum and the minimum values of indication error of all measurement points in both retract and extend directions.		
	1/10 revolution indication error		Set the dial indicator on the supporting stand, and read the indication error ^{*1} of the next point while gradually retracting the spindle. - Every 1/10 revolution for the first two revolutions ^{*2}		During the first two revolutions in both retract and extend directions, obtain the maximum difference of the indication error among the adjacent measurement points per 1/10 revolutions. ^{*3}
	1/2 revolution indication error		- Every half revolution from two to five revolutions - Every revolution from five to ten revolutions - Every five revolutions from 10 to 50 revolutions - Every ten revolutions after 50 revolutions		During the first five revolutions in both retract and extend directions, obtain the maximum difference of the maximum and the minimum indication errors over the measuring range per 1/2 revolutions.
	1 revolution indication error		Next, after retracting the spindle for more than three graduations of the long hand, extend the spindle gradually and read the indication error at the same measurement point in the retract direction.		During the first ten revolutions in both retract and extend directions, obtain the maximum difference of the maximum and the minimum indication errors over the measuring range per one revolution.
Retrace error	One-revolution dial indicator and multi-revolution dial indicator		Obtain the maximum difference of all the measuring points in reference to the indication error at the same measuring point in both forward and backward directions.		
Repeatability	One-revolution dial indicator and multi-revolution dial indicator	Set the dial indicator on the supporting stand, retract the spindle at a desired position within the measuring range. Then, extend the spindle quickly and slowly five times and read each value.	Obtain the maximum difference among five indication values.		
Measuring force	One-revolution dial indicator and multi-revolution dial indicator	Set the dial indicator on the supporting stand, retract and extend the spindle continuously and gradually, and read the measuring force at the zero and end points.	Obtain the maximum measuring force, the minimum measuring force, and the difference of the measuring force in both retract and extend directions at the same measurement point.		

*1: For how to read the indication error, either read the input quantity of the measuring instrument aligning the long hand to the graduation, or read the indication value of the dial indicator according to the moving amount of the measuring instrument.
 *2: With the one-revolution dial indicator, read the indication error per 10 graduations.
 *3: With the one-revolution dial indicator, obtain the maximum difference of the indication error in the interval of adjacent 10 graduations.

Mitutoyo's Response to Dial Indicator JIS B 7503:2017

- We guarantee the accuracy of completed products by inspecting them in the vertical posture. Standard-attached inspection certificate includes inspection data.
- We issue paid-for calibration results for horizontal or opposite posture if required.

Digital indicators JIS B 7563 : 2021 (Extract from JIS/Japanese Industrial Standards)

Item.	Measuring method (zero-point fixed)	Evaluation method (performance evaluation by moving the zero point)	Measurement examples
Indication error	Indication error over a portion of the measuring range (in the forward direction)	Obtain the difference between the maximum and the minimum values of indication error of all measurement points of the partial measuring range in the forward direction.	
	Indication error over the entire measuring range (in the forward direction) E_{MPE}	Obtain the difference between the maximum and the minimum values of indication error of all measurement points of the entire measuring range in the forward direction. a) Include the measurement points in the partial measuring range when determining the indication error for the entire measuring range.	
	Retrace error H_{MPE}	Obtain the maximum difference in reference to the indication error at the same measuring point in both forward and backward directions for the partial measuring range and entire measuring range. c) For how to read the indication error, either read the input quantity of the measuring instrument with the digital indicator value, or read the digital indicator value according to the moving amount of the measuring instrument.	
Repeatability R_{MPE}	Set the digital indicator on the supporting stand, retract the contact point into any position within the measuring range, and actuate it five times in the backward direction. Move the contact point quickly and slowly and read the indicated value each time.	Obtain the maximum difference among five indication values.	
Measuring force MPL	Set the digital indicator on the supporting stand, retract and extend the spindle continuously and gradually, and read the measuring force at the zero and end points.	Obtain the maximum measuring force, the minimum measuring force, and the difference of the measuring force in both retract and extend directions at the same measurement point.	

Digital indicator maximum permissible error (MPE)

Characteristic	Minimum reading (mm)	0.01				0.001				0.0005			
	Partial measuring range (mm)	0.5				0.05				0.025			
	Measuring range (mm)	15 or less	Over 15 and up to 30	Over 30 and up to 60	Over 60 and up to 100	15 or less	Over 15 and up to 30	Over 30 and up to 60	Over 60 and up to 100	15 or less	Over 15 and up to 30	Over 30 and up to 60	Over 60 and up to 100
Indication error over a portion of the measuring range (in the forward direction) P_{MPE} (μm)		20		40		3		5		3		5	
Indication error over the entire measuring range (in the forward direction) E_{MPE} (μm)		20		40		3		5		3		5	
Retrace error H_{MPE} (μm)			20				3				3		
Repeatability R_{MPE} (μm)			20				2				2		

Mitutoyo's Response to Digital Indicators JIS B 7563:2021

- We guarantee the accuracy of completed products by inspecting them in the vertical posture. Standard-attached inspection certificate includes inspection data.
- We issue paid-for calibration results for horizontal or opposite posture if required.

Lever-Operated Dial Indicator Standard B7533 : 2015 (Extract from JIS/Japanese Industrial Standards)

No.	Item.	Measuring method	Measuring point	Evaluation method	Diagram
1	Indication error over the entire measuring range (in the forward direction)	Holding the dial test indicator (lever type), define the reference point at near the contact point resting point	Per 10 graduations in the forward and backward direction from the reference point to the end point.	Obtain the difference between the maximum and the minimum values of indication error of all measurement points in the forward direction.	
2	10 graduations indication error	where the indication and error of indication is set zero. Then, move the contact point in the forward direction and read the error of indication at each measuring point. Next, after moving the contact point for more than three graduations from the end of the measuring range, move the contact point in the backward direction and read the error of indication at the same measurement point in the forward direction. (The forward direction is the direction against the measuring force to the contact point of the lever-operated dial indicator; the backward direction is the measuring force applied direction.)		In the forward direction from the reference point to the end point, obtain the maximum difference of the indication error among the adjacent measurement points per 10 graduations.	
3	1 revolution indication error			In the forward direction from the reference point to the end point, obtain the maximum difference of the maximum and the minimum indication errors to be read by the zero-point fixed method over the measuring range per 1 revolution.	
4	Retrace error			Obtain the maximum difference in reference to the indication error at the same measuring point in both forward and backward directions among all the measurement points.	
5	Repeatability	Holding the dial test indicator (lever type) with its stylus parallel with the top face of the measuring stage, move the contact point quickly and slowly five times at a desired position within the measuring range and read the indication at each point.	At arbitrary points within the measuring range	Obtain the maximum difference of the five measured values.	
6	Measuring force	Holding the dial test indicator (lever type), move the contact point in the forward and backward directions continuously and gradually, and read the measuring force in the measuring range.	Reference point and end point within the measuring range	Obtain the maximum and the minimum values in reference to the measuring force.	

● Maximum permissible error and permissible limits

Graduation (mm)		0.001/0.002			0.01		
Revolution		1 revolution	Multi-revolution		1 revolution	Multi-revolution	
Measuring range (mm)		0.3 or less	Over 0.3, up to 0.5	Over 0.5, up to 0.6	0.5 or less	Over 0.5, up to 1.0	Over 1.0, up to 1.6
						$L_1 \leq 35$	$35 < L_1$
Indication error (μm)	Measuring range (μm)	4	6	7	6	9	10
	One revolution	—	5	5	—	—	10
	10 scale divisions (μm)	2	2	2	5	5	5
Retrace error (μm)		3	4	4	4	4	5
Repeatability (μm)		1	1	1	3	3	3
Measuring force (N)	Max.	0.5	0.5	0.5	0.5	0.5	0.5
	Min.	0.01	0.01	0.01	0.01	0.01	0.01

Dial Test Indicators and the Cosine Effect

Always minimize the angle between movement directions during use.

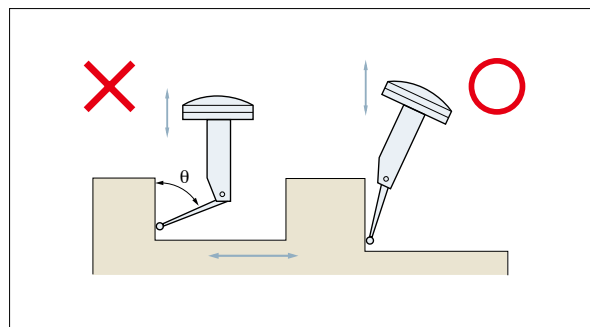
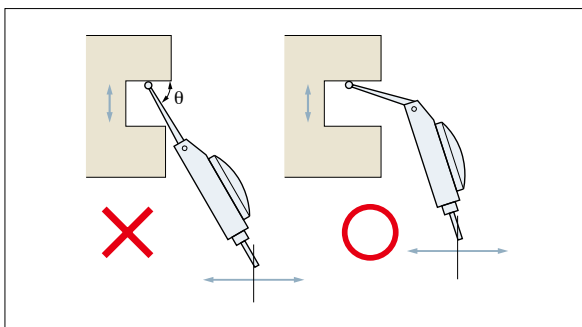
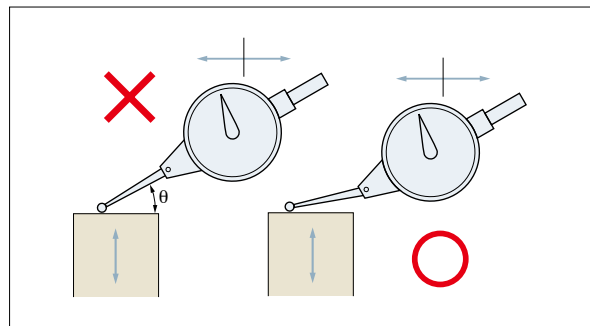
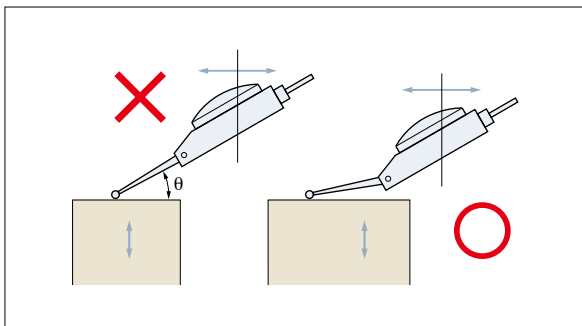
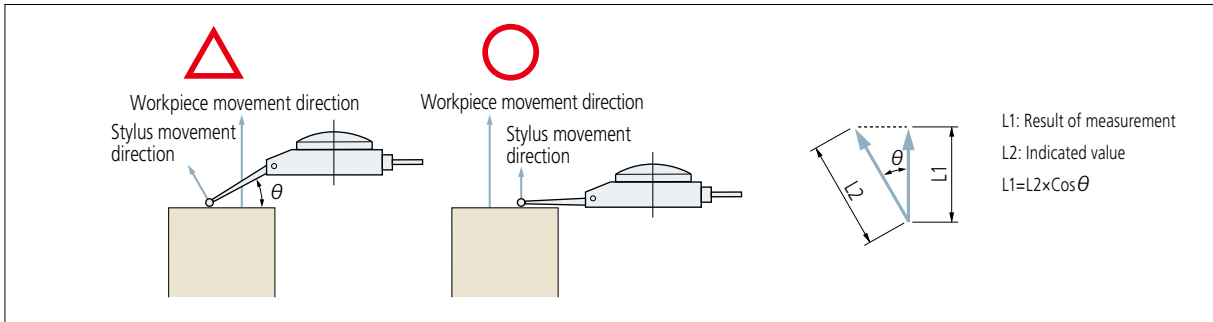

When the test indicator's contact point comes into contact with the measuring face, an error will occur depending on the angle. When bringing the contact point into contact with the measuring face, set the angle θ shown in the figure as small as possible. The measured value will vary depending on the value of θ . Correct the measured value from the θ value according to the table.

Result of measurement = indicated value x compensation value

Compensating for a non-zero angle

Angle	Compensation value
10°	0.98
20°	0.94
30°	0.87
40°	0.77
50°	0.64
60°	0.50

Examples

If a 0.002 mm measurement is indicated on the dial at various values of θ , the result of measurements are:

$\theta = 10^\circ \quad 0.002 \text{ mm} \times 0.98 = 0.00196 \text{ mm}$
 $\theta = 20^\circ \quad 0.002 \text{ mm} \times 0.94 = 0.00188 \text{ mm}$
 $\theta = 30^\circ \quad 0.002 \text{ mm} \times 0.87 = 0.00174 \text{ mm}$

- Mitutoyo's Response to Lever-operated Dial Indicator B 7533 : 2015

We guarantee the accuracy of completed products as follows.

- Vertical, tilted, and perpendicular: We perform inspections with the dial face up.
 - Horizontal: We perform inspections with the dial face in a vertical posture.
- Standard-attached inspection certificate includes inspection data.

- We issue paid-for calibration results for other postures not mentioned above if required.