

02

Micrometers

MeasurLink[®] ENABLED

Data Management Software by Mitutoyo

Measurement Data Network System

MeasurLink[®] is a measurement data management system based on databases (SQL Server). You can build a network to manage the measurement results and measuring instruments simply by combining the required functions.

MeasurLink[®] is a registered trademark of Mitutoyo Corporation in Japan and Mitutoyo America Corporation in the United States.

U-WAVE^{fit}

Measurement Data Wireless

Communication System

Bluetooth[®] communication enables wireless transfer of measurement data from Digimatic micrometers and callipers to PCs, smartphones, tablets and such other devices.

IP65

IP Codes

The code indicates the degree of protection against the ingress of foreign materials and water as defined in the IEC standard (IEC 60529). The number indicates the protection level. (Refer to page 3)



TÜV Rheinland Certification Marks

All products with the marks have passed the IP test carried out by the German accreditation organization, TÜV Rheinland.



Measuring Instruments Shipped with Inspection Certificate

Mitutoyo guarantees product quality as a leading precision measuring instrument manufacturer and ships measuring instruments with an inspection certificate that includes inspection data so that customers can use them with confidence.

ABSOLUTE[™]

ABSOLUTE Linear Encoder

Mitutoyo developed the unique ABSOLUTE method to retain position information after the power is turned off. The origin is set once - thereafter the live position is displayed when the power is turned on.

DIGIMATIC S1

DIGIMATIC S1

Mitutoyo's proprietary bidirectional serial communication protocol enables a connected PC to execute measurement data output, setting and control of a measuring instrument, and capture of information of a specific measuring instrument.



Ultra-high Accuracy Digimatic Micrometer



High-speed and High-accuracy Digimatic Micrometer QuantuMike



Coolant Proof Micrometers

INDEX

Outside Micrometers (Digimatic)

Ultra-high Accuracy Digimatic Micrometer	02-3
High-speed and High-accuracy Digimatic Micrometer QuantuMike	02-5
Coolant Proof Micrometers (IP65 Digimatic Micrometer)	02-7
Digimatic Outside Micrometers	02-9
Quickmike	02-11
ABSOLUTE Digimatic Micrometers	02-12
Outside Micrometers (Non-rotating Spindle Type)	02-13
Outside Micrometers with Interchangeable Anvils	02-14

Outside Micrometers (Analog)

Outside Micrometers	02-16
Ratchet Thimble Micrometer	02-17
Outside Micrometers	02-18
Digit Outside Micrometers	02-21
Outside Micrometers with Interchangeable Anvils	02-23
Outside Micrometers with Anvil Extension Collars	02-25
Indicator Type Micrometers	02-28

Special Purpose Micrometers

Caliper Type Micrometers	02-29
Screw Thread Micrometers	02-31
Screw Thread Micrometers (Interchangeable Anvil/Spindle Tip Type)	02-32
Disc Micrometers	02-34
Gear Tooth Micrometers (Interchangeable Ball Anvil/Spindle Tip Type)	02-37
Disc Micrometers (Non-rotating Spindle Type)	02-39
Paper Thickness Micrometers	02-42
Sheet Metal Micrometers	02-43
Tube Micrometers	02-46
Tube Micrometers (Spherical Anvil and Spindle Type)	02-47
Tube Micrometers (Spherical and Cylindrical Anvil Type)	02-48
Spline Micrometers	02-49
Point Micrometers	02-51
V-Anvil Micrometers	02-53
Blade Micrometers (Non-rotating Spindle Type)	02-55
Can Seam Micrometers	02-58
Hub Micrometers	02-58
Crimp Height Micrometers	02-59
“Uni-Mike”	02-61
Limit Micrometers	02-62
Indicating Micrometers	02-63
Dial Snap Meters	02-65
Snap Meters	02-66
Groove Micrometers	02-67
QUICKmini	02-68

Accessories, Options

Telescoping Gage Set	02-69
Optical Parallels	02-70
Optical Flats	02-70
Setting Standards for Outside Micrometers	02-71
Setting Standards for Screw Thread Micrometers	02-73
Setting Standards for V-anvil Micrometers	02-73
3-Wire Units	02-74
Lubricant for Measuring Tools	02-74
Color-Coded Ratchet and Speeder Covers	02-75
Micrometer Stands	02-76

Micrometer

MeasurLink[®] ENABLED
Data Management Software by Mitutoyo

ABSOLUTE[™]



Ultra-high Accuracy Digimatic Micrometer SERIES 293

- The flagship model, featuring unparalleled high accuracy and resolution.
- Maximum Permissible Error (J_{MPE}) of $\pm 0.5 \mu\text{m}$ is achieved with our innovative $0.1 \mu\text{m}$ resolution ABS (absolute) rotary sensor and screw machining technology.
- A highly rigid frame and high-performance constant-force mechanism allow stable measurements.
- Body heat transferred to the instrument is reduced by a (removable) heat shield, minimizing the error caused by thermal expansion of the frame when performing handheld measurements.



Measurement example



Recommended micrometer stand: 156-101-10

SPECIFICATIONS

	Metric	Inch/Metric
Code No.	293-100-20	293-130-20
Measuring range	0 – 25 mm	0 – 1 in
Resolution	0.0001 mm/0.0005 mm (switchable)	0.000005 in/0.00002 in 0.0001 mm/0.0005 mm (switchable)
Maximum permissible error J_{MPE}	$\pm 0.5 \mu\text{m}$	± 0.00002 in
Flatness	0.3 μm	0.000012 in
Parallelism	0.6 μm	0.000024 in
Measuring surface	$\phi 3.2$ mm	
Measuring force	7 to 9 N	
Position detection method	Electromagnetic induction type ABS rotary sensor	
Mass	405 g (445 g with heat shield attached)	
Power source	Lithium battery (CR2032) $\times 1$	
Battery life	Approx. two years when used under normal conditions	

Functions

Preset (ABS measurement system):

The measurement origin can be preset to any value within the display range for convenience in measuring.

Zero-setting (INC measurement system):

The display can be zeroed at any position of the spindle, making comparison measurement easier. Returning to the absolute-measurement mode is easily accomplished.

Hold:

The function that holds the display of value is useful when it is difficult to see the measured value at the measurement point. When the function is cancelled, the previous zero-set point or a measured value with reference to the origin is displayed.

Resolution switching:

The resolution of the display can be switched. If $0.1 \mu\text{m}$ measurement is not required, the resolution can be switched to $0.5 \mu\text{m}$.

Function lock:

Functions such as preset or zero-set can be locked to avoid inadvertently changing the origin position.

On/off:

The power can be turned off after measurement is complete. Even after the power is turned off, the origin or last zero-set position remains in the memory.

Auto power off:

Even if the power is left on, the power turns off automatically if the micrometer is not used within a 20-minute period.

Measurement data output:

Measurement data can be output, allowing easy incorporation of this instrument into a statistical process control or measurement system.

Error display:

In the unlikely event of a display overflow or calculation error, an error message is displayed and measurement stops. Measurement cannot continue until the error is corrected.

Also, if the battery voltage drops below a certain point, the battery indicator will turn on before measurement becomes impossible, warning the user that the battery needs to be replaced.

Optional Accessories

Code No.	Type	Description
264-020	—	USB Input Tool Series USB Keyboard Signal Conversion Type IT-020U
05CZA662	B	Connection cable (1 m)
05CZA663	B	Connection cable (2 m)
06AFM380B	B	USB Input Tool Direct (2 m)
02AZD730G	IP67	U-WAVE-T
02AZD880G	Buzzer	U-WAVE-T
02AZE200	—	U-WAVE-T mounting bracket
02AZD790B	B	Connection cable for U-WAVE-T (160 mm)
02AZE140B	B	Connection cable for U-WAVE-T For foot switch

DIMENSIONS

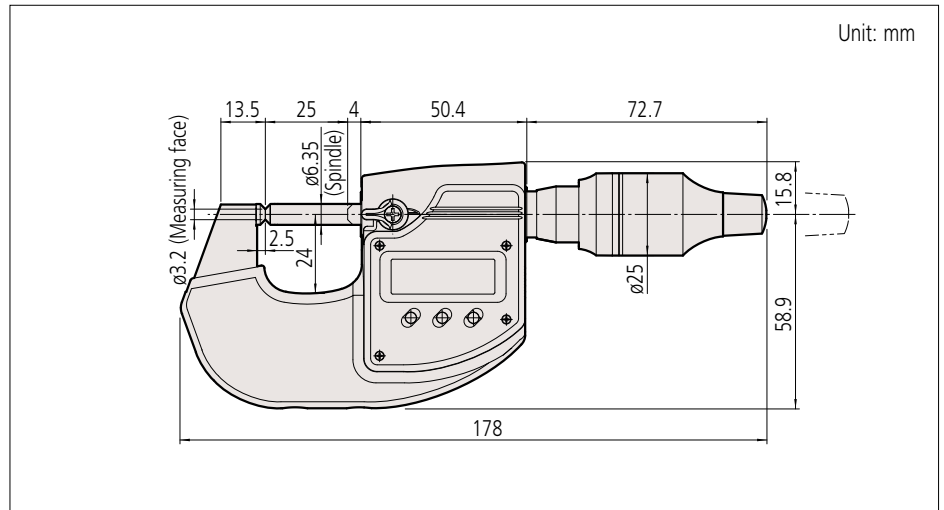

Standard Accessories

- Heat shield (04AAB969A: 293-100-20
04AAB969B: 293-130-20) x1
- Spanner (200877) x1
- Screwdriver (04AAB985) x1
- Cleaning paper for measuring faces 20 sheets
- Inspection certificate



Note: To install the heat shield, use the screws attached to the bottom of the micrometer frame.

Micrometer

MeasurLink[®] ENABLED
Data Management Software by Mitutoyo

U-WAVE fit



Dust- and Water-Protected
www.tuv.com
ID 1111264795



DIGIMATIC S1

High-speed and High-accuracy Digimatic Micrometer QuantuMike SERIES 293 — IP65 Micrometer with 2 mm/rev Spindle Feed

- The spindle moves four times faster than that of the standard micrometer, enabling faster, easier measurement even when it is repeated many times over.
- The approach speed warning function can detect collision with a workpiece at excessive speed, helping inexperienced users obtain reliable and accurate measurement results.
- The calculation function can calculate offsets added to measurement results before they are passed to a machine. This eliminates errors and the effort needed for calculation, helping reduce the number of rejected machined items.
- The Calibration alert function helps with effective measuring instrument management.
- Bidirectional serial communication supported.



293-140-40

SPECIFICATIONS

Metric							
Code No.	Range (mm)	Resolution (mm)	Measuring force*1 (N)	Maximum permissible error J_{MPE} (μm)	Flatness (μm)	Parallelism (μm)	Mass (g)
With SPC data output							
293-140-40	0 - 25	0.001	7 to 12	±1	0.3	1	265
293-141-40	25 - 50						325
293-142-40	50 - 75						465
293-143-40	75 - 100						620
Inch / Metric							
Code No.	Range (in)	Resolution	Measuring force*1 (N)	Maximum permissible error J_{MPE} (in)	Flatness (in)	Parallelism (in)	Mass (g)
With SPC data output							
293-180-40	0 - 1	0.00005 in/ 0.001 mm	7 to 12	±0.00005	0.000012	0.00004	265
293-181-40	1 - 2						325
293-182-40	2 - 3						465
293-183-40	3 - 4						620

- Dust/Water protection level: IP65 (IEC60529)*2
- Power source: CR2032 battery (1 pc.), included as standard (for operational checks)
- Battery life: Approx. 2 years under normal use
- Position detection method: Electromagnetic rotary sensor
- Standard accessories: Setting standard, 1 pc. (except for 0 to 25 mm (0 to 1 in) models), Spanner (301336), 1 pc.
- *1 Measuring force when using the speeder ratchet (Apply a measuring force in the same condition as for measurement and then set the origin.)
- *2 Rustproofing shall be applied after use.

Measurement example



Comparison of time needed to measure a 6-stepped workpiece (with one hand)

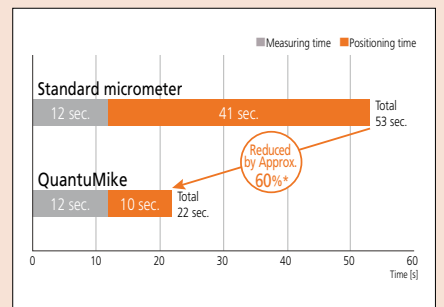

* According to Mitutoyo's comparison test data for measuring time on typical workpieces.

Ratchet thimble mechanism

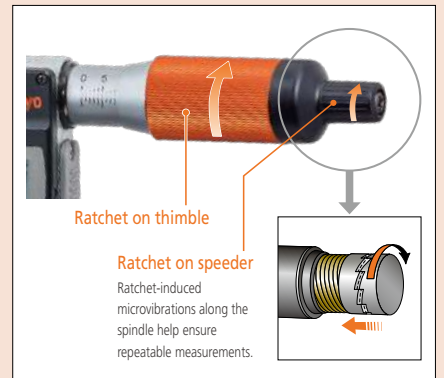

Functions

Preset (ABS measurement system):

The measurement origin can be preset to any value within the display range for convenience in measuring.

Zero-setting (INC measurement system):

The display can be zeroed at any position of the spindle, making comparison measurement easier.

Returning to the absolute-measurement mode is easily accomplished.

Hold:

The function that holds the display of value is useful when it is difficult to see the measured value at the measurement point.

When the function is cancelled, the previous zero-set point or a measured value with reference to the origin is displayed.

Calibration alert:

This function gives an alert when the instrument is approaching its calibration date and again on the actual calibration due date, helping to ensure better measuring instrument management by preventing missed calibrations.

Approach speed warning:

Reduces variation in measurement values and improves reliability of measurements.

Tolerance judgment:

The function determines whether a measured value is within the range between the upper and lower tolerance limits and displays the result with a tolerance judgment mark.

Function lock:

Functions such as preset or zero-set can be locked to avoid inadvertently changing the origin position.

Auto power ON/OFF:

The reading on the LCD disappears after this instrument is idle for approx. 20 minutes, but the origin point is retained. Turning the spindle causes the reading on the LCD to reappear.

Key customization:

Frequently used functions can be assigned to buttons and called back easily, improving work efficiency.

Measurement data output:

Measurement data can be output, allowing easy incorporation of this instrument into a statistical process control or measurement system.

Error display:

In the unlikely event of a display overflow or calculation error, an error message is displayed and measurement stops. Measurement cannot continue until the error is corrected.

Also, if the battery voltage drops below a certain point, the battery indicator will turn on before measurement becomes impossible, warning the user that the battery needs to be replaced.

DIMENSIONS

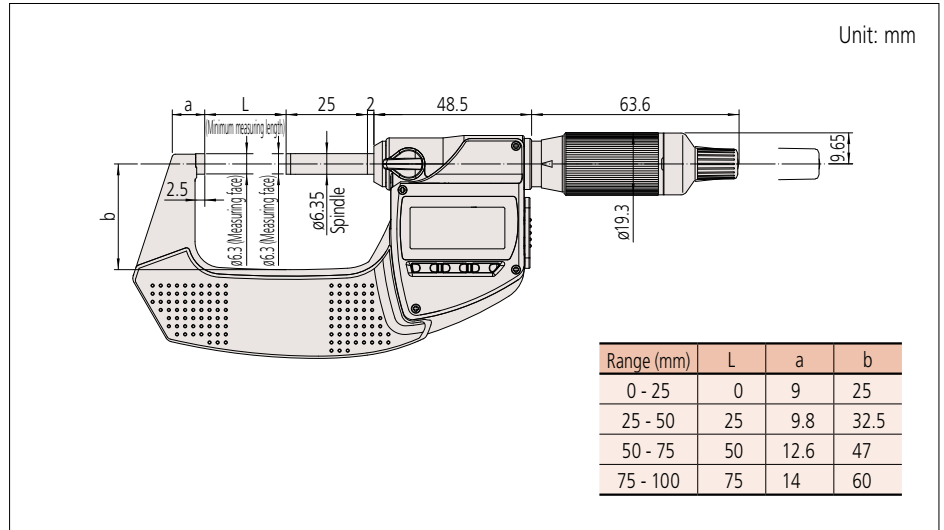

Optional Accessories

Code No.	Type	Description
264-020	—	USB Input Tool Series USB Keyboard Signal Conversion Type IT-020U
06AGL111	SA	Connection cable (1 m)
06AGL121	SA	Connection cable (2 m)
06AGQ001A	SA	USB Input Tool Direct (2 m)
264-622	IP67	U-WAVE-TM
264-623	Buzzer	U-WAVE-TM
264-626	IP67	U-WAVE-TMB
264-627	Buzzer	U-WAVE-TMB
02AZF960	IP67	Connecting unit for U-WAVE-TM/TMB

Micrometer

MeasurLink[®] ENABLED
Data Management Software by Mitutoyo

U-WAVE^{fit}



Coolant Proof Micrometers SERIES 293 — IP65 Digimatic Micrometer

- Accurate and highly environmentally resistant, assisting with many types of measurements.
- Ratchet thimble provides better operability for one-handed operation.
- Oil-resistant material used for all plastic parts.
- Models equipped with a Digimatic output port can form part of a statistical process control or networked measurement system.



293-230-30

SPECIFICATIONS

Metric								
Code No.	Range (mm)	Resolution (mm)	Measuring force*1 (N)	Maximum permissible error J_{MPE} (μm)	Parallelism (μm)	Flatness (μm)	Constant measuring force	Mass (g)
With SPC data output								
293-230-30	0 - 25	0.001	5 - 10	±1	1	0.3	With ratchet stop	270
293-231-30	25 - 50							330
293-232-30	50 - 75							470
293-233-30	75 - 100		625					
293-234-30	0 - 25		7 - 12	±1	1		With ratchet thimble	280
293-235-30	25 - 50							340
293-236-30	50 - 75	480						
293-237-30	75 - 100	±2	2	635				
Without SPC data output								
293-240-30	0 - 25	0.001	5 - 10	±1	1	0.3	With ratchet stop	270
293-241-30	25 - 50							330
293-242-30	50 - 75							470
293-243-30	75 - 100		625					
293-244-30	0 - 25		7 - 12	±1	1		With ratchet thimble	280
293-245-30	25 - 50							340
293-246-30	50 - 75	480						
293-247-30	75 - 100	±2	2	635				

Inch / Metric								
Code No.	Range (in)	Resolution	Measuring force*1 (N)	Maximum permissible error J_{MPE} (in)	Parallelism (in)	Flatness (in)	Constant measuring force	Mass (g)
With SPC data output								
293-330-30	0 - 1	0.00005 in / 0.001 mm	5 - 10	±0.00005	0.00004	0.000012	With ratchet stop	270
293-331-30	1 - 2							330
293-332-30	2 - 3							470
293-333-30	3 - 4		625					
293-334-30	0 - 1		7 - 12	±0.00005	0.00004		With ratchet thimble	280
293-335-30	1 - 2							275
293-336-30	1 - 2	335						
Without SPC data output								
293-340-30	0 - 1	0.00005 in / 0.001 mm	5 - 10	±0.00005	0.00004	0.000012	With ratchet stop	270
293-341-30	1 - 2							330
293-342-30	2 - 3							470
293-343-30	3 - 4		625					
293-344-30	0 - 1		7 - 12	±0.00005	0.00004		With ratchet thimble	280
293-345-30	1 - 2							340
293-346-30	2 - 3	480						
293-347-30	3 - 4	±0.0001	0.00008	635				
293-348-30	0 - 1	0.0001 in / 0.001 mm	5 - 10	±0.00005	0.00004	With friction thimble	275	
293-349-30	1 - 2		7 - 12	±0.0001			280	

- Dust/water protection level: IP65 (IEC60529)*2
 - Power source: SR44 battery (1 pc.), **938882** included as standard (for operational checks)
 - Battery life: Approx. 2.4 years under normal use
 - Position detection method: Electromagnetic rotary sensor
 - Standard accessories: Setting standard, 1 pc. (except for 0 to 25 mm (0 to 1 in) models), Spanner (**301336**), 1 pc.
 - *1 Measuring force when using the speeder ratchet (Apply a measuring force in the same condition as for measurement and then set the origin.)
 - *2 Rustproofing shall be applied after use.
- Note: All digits of models over 125 mm (5 in) measuring range are presettable.

DIMENSIONS

Measuring range: 100 mm or less

Range (mm)	Code No.	L	a	b	c
0 - 25	293-230-30 / 293-240-30	0	6.5	25	2.5
25 - 50	293-231-30 / 293-241-30	25	7.3	32.5	
50 - 75	293-232-30 / 293-242-30	50	10.1	47	2.5
75 - 100	293-233-30 / 293-243-30	75	11.5	60	
0 - 25	293-234-30 / 293-244-30	0	6.5	25	2.5
25 - 50	293-235-30 / 293-245-30	25	7.3	32.5	

Functions

Origin point setting (ABS measurement system): Resets the ABS origin at the current spindle position to the minimum value of the measuring range and switches to ABS mode.

Zero-setting:

A brief press on the ZERO/ABS button sets display to zero at the current spindle position and switches to the incremental (INC) measuring mode. A longer press resets to the ABS measuring mode.

Hold:

The function that holds the display of value is useful when it is difficult to see the measured value at the measurement point. When the function is cancelled, the previous zero-set point or a measured value with reference to the origin is displayed.

Data output*:

Models equipped with this function have an output port for transferring measurement data to a Statistical Process Control (SPC) system.

* Only models with the data output function

Auto power ON / OFF:

The reading on the LCD disappears after this instrument is idle for about 20 minutes, but the reading and measurement mode are retained. Turning the spindle causes the reading to reappear.

Error display:

In case of an overflow on the LCD or a computing error, an error message appears on the LCD, and the measuring function stops. This prevents an instrument from giving an erroneous reading. Also, when the battery voltage drops to a certain level, the low-battery-voltage alarm indicator appears well before the micrometer becomes unusable.

Function lock:

This function allows the ORIGIN (origin point setting) function and the ZERO (zero-setting) function to be locked to prevent these points being reset accidentally.

Optional Accessories

Refer to page 02-8.

Micrometer sets

293-962-30 (Metric)

- Range: 0 - 75 mm (3 pcs./set)
- Models included: **293-230-30, 293-231-30, 293-232-30**

293-963-30 (Metric)

- Range: 0 - 100 mm (4 pcs./set)
- Models included: **293-230-30, 293-231-30, 293-232-30, 293-233-30**

293-966-30 (Metric)

- Range: 0 - 50 mm (2 pcs./set)
- Models included: **293-230-30, 293-231-30**

293-960-30 (Inch/Metric)

- Range: 0 - 2 in (3 pcs./set)
- Models included: **293-330-30, 293-331-30, 293-332-30**

293-961-30 (Inch/Metric)

- Range: 0 - 3 in (4 pcs./set)
- Models included: **293-330-30, 293-331-30, 293-332-30, 293-333-30**



Dust- and Water- Protected
www.tuv.com
ID: 000004091



Coolant Proof Micrometers SERIES 293 — IP65 Digimatic Micrometer

Functions

Refer to page 02-7.

Optional Accessories

Only for models with data output function

Code No.	Type	Description
264-020	—	USB Input Tool Series USB Keyboard Signal Conversion Type IT-020U
05CZA662	B	Connection cable (1 m)
05CZA663	B	Connection cable (2 m)
06AFM380B	B	USB Input Tool Direct (2 m)
02AZD730G	IP67	U-WAVE-T
02AZD880G	Buzzer	U-WAVE-T
02AZE200	—	U-WAVE-T mounting bracket
02AZD790B	B	Connection cable for U-WAVE-T (160 mm)
02AZE140B	B	Connection cable for U-WAVE-T For foot switch
264-622	IP67	U-WAVE-TM
264-623	Buzzer	U-WAVE-TM
264-626	IP67	U-WAVE-TMB
264-627	Buzzer	U-WAVE-TMB
02AZF310	IP67	Connecting unit for U-WAVE-TM/TMB

- Accurate and highly environmentally resistant, assisting with many types of measurements.
- Models equipped with a Digimatic output port can form part of a statistical process control or networked measurement system.
- Oil-resistant material used for all plastic parts.



SPECIFICATIONS

Metric								
Code No.	Range (mm)	Resolution (mm)	Measuring force*1 (N)	Maximum permissible error J_{MPE} (μm)	Parallelism (μm)	Flatness (μm)	Constant measuring force	Mass (g)
With SPC data output								
293-250-30	100 - 125	0.001	5 - 10	±2	3	0.3	With ratchet stop	600
293-251-30	125 - 150							740
293-252-30	150 - 175			±3	4			800
293-253-30	175 - 200							970
293-254-30	200 - 225			±4	5			1100
293-255-30	225 - 250							1270
293-256-30	250 - 275							1370
293-257-30	275 - 300							1590

Inch / Metric								
Code No.	Range (in)	Resolution	Measuring force*1 (N)	Maximum permissible error J_{MPE} (in)	Parallelism (in)	Flatness (in)	Constant measuring force	Mass (g)
With SPC data output								
293-350-30	4 - 5	0.0001 in / 0.001 mm	5 - 10	±0.0001	0.00012	0.000012	With ratchet stop	600
293-351-30	5 - 6							740
293-352-30	6 - 7			±0.00015	0.00016			800
293-353-30	7 - 8							970
293-354-30	8 - 9			±0.0002	0.0002			1100
293-355-30	9 - 10							1270
293-356-30	10 - 11							1370
293-357-30	11 - 12							1590

- Dust/water protection level: IP65 (IEC60529)*2
 - Power source: SR44 battery (1 pc.), **938882** included as standard (for operational checks)
 - Battery life: Approx. 2.4 years under normal use
 - Position detection method: Electromagnetic rotary sensor
 - Standard accessories: Setting standard, 1 pc. (except for 0 to 25 mm (0 to 1 in) models), Spanner (**301336**), 1 pc.
- *1 Measuring force when using the speeder ratchet (Apply a measuring force in the same condition as for measurement and then set the origin.)
- *2 Rustproofing shall be applied after use.
- Note: All digits of models over 125 mm (5 in) measuring range are presettable.

DIMENSIONS

Unit: mm

Range (mm)	Code No.	L	a	b	c
100 - 125	293-250-30	100	16.7	76	5.3
125 - 150	293-251-30	125	18.8	90	5.7
150 - 175	293-252-30	150	19.1	103	6.1
175 - 200	293-253-30	175	18.2	115	6.3
200 - 225	293-254-30	200	16.8	126	6.7
225 - 250	293-255-30	225	18	139	5.5
250 - 275	293-256-30	250		152	6.5
275 - 300	293-257-30	275	166		

Micrometer

MeasurLink ENABLED
Data Management Software by Mitutoyo

Digimatic Outside Micrometers SERIES 293

- This large Digimatic micrometer series is available in various sizes up to 500 mm. It features a ratchet stop for constant measuring force.
- Measuring faces: Carbide tipped
- All models have a measurement data output function that is useful for measuring large workpieces. This function allows you to easily send data via an optional communication cable or wireless system and import it to spreadsheet software or use it in various applications.



293-582

SPECIFICATIONS

Metric						
Code No.	Range (mm)	Resolution (mm)	Measuring force (N)	Maximum permissible error J_{MPE} (μm)	Flatness (μm)	Parallelism (μm)
With SPC data output						
293-582	300 - 325	0.001	10 - 15	±6	0.6	5
293-583	325 - 350					
293-584	350 - 375					
293-585	375 - 400			±7		6
293-586	400 - 425					
293-587	425 - 450			±8		7
293-588	450 - 475					
293-589	475 - 500					

Inch / Metric						
Code No.	Range (in)	Resolution	Measuring force (N)	Maximum permissible error J_{MPE} (in)	Flatness (in)	Parallelism (in)
With SPC data output						
293-782	12 - 13	0.0001 in / 0.001 mm	10 - 15	±0.0003	0.000024	0.0002
293-783	13 - 14					
293-784	14 - 15			±0.00035		0.00024
293-785	15 - 16					
293-786	16 - 17					
293-787	17 - 18			±0.0004		0.00028
293-788	18 - 19					
293-789	19 - 20					

- Power source: SR44 battery (2 pcs.), **938882** included as standard (for operational checks)
- Battery life: Approx. 1.8 years under normal use
- Position detection method: Electromagnetic rotary sensor
- Standard accessories: Setting standard, 1 pc., Spanner (**200154**), 1 pc.

DIMENSIONS

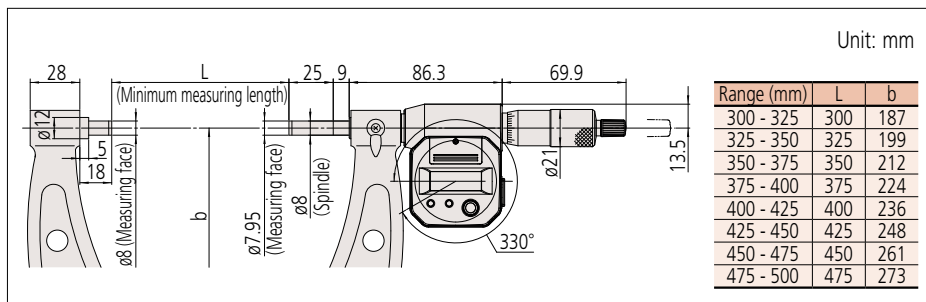

Functions

Origin point setting (ABS measurement system): Resets the ABS origin at the current spindle position to the minimum value of the measuring range and switches to ABS mode.

Zero-setting (INC measurement system): A brief press on the ZERO/ABS button sets display to zero at the current spindle position and switches to the incremental (INC) measuring mode. A longer press resets to the ABS measuring mode.

Hold: The function that holds the display of value is useful when it is difficult to see the measured value at the measurement point. When the function is cancelled, the previous zero-set point or a measured value with reference to the origin is displayed.

Function lock: This function allows the PRESET (origin point setting) function and the ZERO (zero-setting) function to be locked to prevent these points being reset accidentally.

Auto power ON / OFF: The reading on the LCD disappears after this instrument is idle for about 20 minutes, but the reading and measurement mode are retained. Turning the spindle causes the reading to reappear.

Data output: Models equipped with this function have an output port for transferring measurement data to a Statistical Process Control (SPC) system.

Error display: In case of an overflow on the LCD or a computing error, an error message appears on the LCD, and the measuring function stops. This prevents an instrument from giving an erroneous reading. Also, when the battery voltage drops to a certain level, the low-battery-voltage alarm indicator appears well before the micrometer becomes unusable.

Optional Accessories

Code No.	Type	Description
264-020	—	USB Input Tool Series USB Keyboard Signal Conversion Type IT-020U
04AZB512	CR	Connection cable (1 m)
04AZB513	CR	Connection cable (2 m)
959149	C	Connection cable (1 m)
959150	C	Connection cable (2 m)
06AFM380C	C	USB Input Tool Direct (2 m)
02AZD730G	IP67	U-WAVE-T
02AZD880G	Buzzer	U-WAVE-T
02AZE200	—	U-WAVE-T mounting bracket
02AZD790C	C	Connection cable for U-WAVE-T (160 mm)
02AZE140C	C	Connection cable for U-WAVE-T For foot switch



Functions

Zero-setting:

A brief press on the ORIGIN button sets display to zero at the current spindle position (zero-setting), which allows easy comparison measurement.

Auto power ON/OFF:

The reading on the LCD disappears after this instrument is idle for about 20 minutes, but the reading is retained. Turning the spindle causes the reading on the LCD to reappear.

Error display:

In case of an overflow on the LCD or a computing error, an error message appears on the LCD, and the measuring function stops. This prevents an instrument from giving an erroneous reading. Also, when the battery voltage drops to a certain level, the low-battery-voltage alarm indicator appears well before the micrometer becomes unusable.

**Digimatic Outside Micrometers
SERIES 293**

- Simple design with no data output for accuracy at a lower cost.
- Provided only with an origin-set button for easy origin setting.
- Extended battery life of approximately 2.4 years, which helps reduce the number of battery replacements required.
- Equipped with Ratchet Stop for constant measuring force.
- Measuring faces: Carbide tipped



293-821-30

SPECIFICATIONS

Metric		With ratchet stop					
Code No.	Range (mm)	Resolution (mm)	Measuring force (N)	Maximum permissible error J_{MPE} (μ m)	Flatness (μ m)	Parallelism (μ m)	Mass (g)
Without SPC data output							
293-821-30	0 - 25	0.001	5 - 10	± 2	0.3	2	270

Inch / Metric		With ratchet stop					
Code No.	Range (in)	Resolution	Measuring force (N)	Maximum permissible error J_{MPE} (in)	Flatness (in)	Parallelism (in)	Mass (g)
Without SPC data output							
293-831-30	0 - 1	0.00005 in/0.001 mm	5 - 10	± 0.0001	0.000012	0.00008	270

Inch / Metric		With friction thimble					
Code No.	Range (in)	Resolution	Measuring force (N)	Maximum permissible error J_{MPE} (in)	Flatness (in)	Parallelism (in)	Mass (g)
Without SPC data output							
293-832-30	0 - 1	0.00005 in/0.001 mm	5 - 10	± 0.0001	0.000012	0.00008	270

- Power source: SR44 battery (1 pc.), **938882** included as standard (for operational checks)
- Battery life: Approx. 2.4 years under normal use
- Position detection method: Electromagnetic rotary sensor
- Spanner (**301336**), 1 pc.

DIMENSIONS

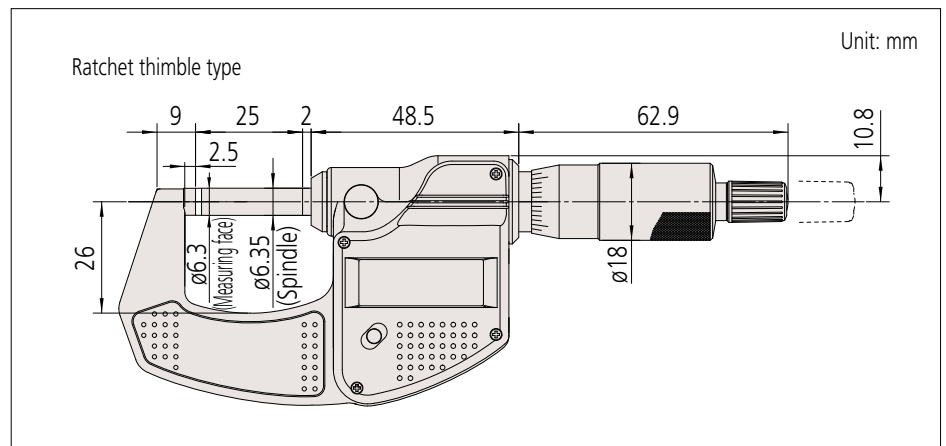

Micrometer

MeasurLink[®] ENABLED
Data Management Software by Mitutoyo

ABSOLUTE[™]



Dust- and
Water-
Protected
www.tuv.com
ID 000063013

Quickmike SERIES 293 — IP65 ABSOLUTE Digimatic Micrometers

- The Quickmike provides a speedy spindle feed of 10 mm per thimble rotation which enables quick measurements of many different-sized features.
- Measuring faces: Carbide tipped
- Equipped with Ratchet Stop for constant measuring force.



293-666-20

SPECIFICATIONS

Metric								
Code No.	Range (mm)	Resolution (mm)	Measuring force (N)	Maximum permissible error J_{MPE} (μm)	Flatness (μm)	Parallelism (μm)	Constant measuring force	Mass (g)
With SPC data output								
293-666-20	0 - 30	0.001	5 - 12	±2	0.3	2	Yes	275
293-667-20	25 - 55							340
293-668-20	50 - 80			480				
293-669-20	75 - 105			585				
Inch / Metric								
Code No.	Range (in)	Resolution	Measuring force (N)	Maximum permissible error J_{MPE} (in)	Flatness (in)	Parallelism (in)	Constant measuring force	Mass (g)
With SPC data output								
293-676-20	0 - 1.2	0.00005 in/ 0.001 mm	5 - 12	±0.0001	0.000012	0.00008	Yes	275
293-677-20	1 - 2.2							340
293-678-20	2 - 3.2			480				
293-679-20	3 - 4.2			585				

- Power source: SR44 battery (1 pc.), 938882 included as standard (for operational checks)
- Battery life: Approx. 5 years under normal use
- Position detection method: Electrostatic capacity absolute sensor
- Standard accessories: Setting standard, 1 pc. (except for measuring range 0 to 30 mm (0 to 1.2 in) models)
- Maximum response speed: without limit
- The non-rotating spindle enables even inexperienced operators to perform measurements repeatably and accurately.

DIMENSIONS

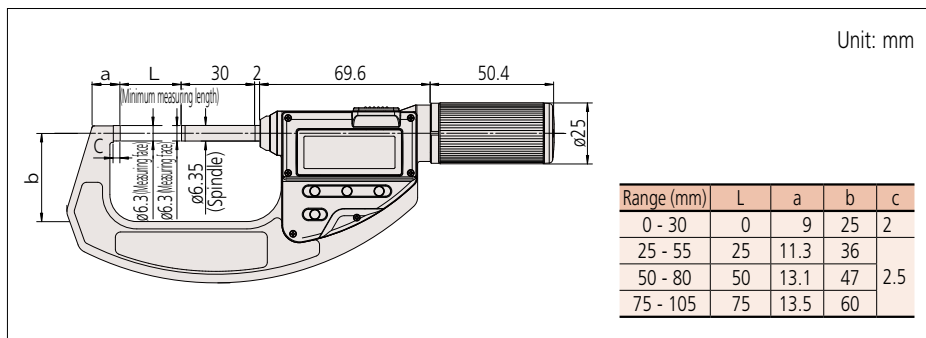

Measurement example



Optional Accessories

Code No.	Type	Description
264-020	—	USB Input Tool Series USB Keyboard Signal Conversion Type IT-020U
05CZA662	B	Connection cable (1 m)
05CZA663	B	Connection cable (2 m)
06AFM380B	B	USB Input Tool Direct (2 m)
02AZD730G	IP67	U-WAVE-T
02AZD880G	Buzzer	U-WAVE-T
02AZE200	—	U-WAVE-T mounting bracket
02AZD790B	B	Connection cable for U-WAVE-T (160 mm)
02AZE140B	B	Connection cable for U-WAVE-T For foot switch

Mechanism

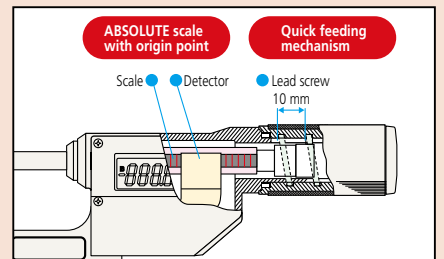

ABSOLUTE Digimatic Micrometers SERIES 227 — with Adjustable Measuring Force

Measurement example



Functions

Adjustable measuring force mechanism, Origin point setting, Zero setting, Hold, Function Lock, Auto power off, Measurement data output, Error display

Optional Accessories

Code No.	Type	Description
264-020	—	USB Input Tool Series USB Keyboard Signal Conversion Type IT-020U
05CZA662	B	Connection cable (1 m)
05CZA663	B	Connection cable (2 m)
06AFM380B	B	USB Input Tool Direct (2 m)
02AZD730G	IP67	U-WAVE-T
02AZD880G	Buzzer	U-WAVE-T
02AZE200	—	U-WAVE-T mounting bracket
02AZD790B	B	Connection cable for U-WAVE-T (160 mm)
02AZE140B	B	Connection cable for U-WAVE-T For foot switch

Adjustable Measuring Force



To preset the measuring force, adjust the measuring force setting scale on the thimble with the screwdriver supplied.

Constant-Measuring-Force Mechanism

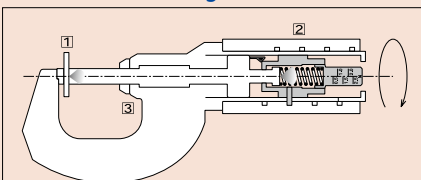

- Measuring force is generated by the action of trapping a workpiece between the spindle and the anvil.
- The constant-force unit applies the specified measuring force.
- When the preset measuring force is reached, the count on the LCD is automatically held and the hold symbol appears.
(To cancel the hold, reverse the thimble more than 1/10 revolution and press the hold button.)

- Digimatic micrometer equipped with a constant/low measuring force mechanism. The measurement-value hold function automatically retains the data at a specified measuring force. (Pressing with a larger force than the specified measuring force does not affect the measurement result.)
- It is suitable for measuring flexible workpieces such as electric wire, paper, and rubber.
- Non-rotating spindle reduces workpiece deformation.
- Measuring faces: Carbide tipped



227-201-20

SPECIFICATIONS

Metric												
Code No.	Range (mm)	Resolution (mm)	Measuring force (N)	Maximum permissible error J_{MPE} (μm)	Flatness (μm)	Parallelism (μm)	Measuring force (N)	Accuracy of the selected measuring force* (N)	Repeatability of measuring force* (N)	Mass (g)		
With SPC data output												
227-201-20	0 - 15	0.001	0.5 - 2.5 (adjustable)	± 2	0.3	2	0.5, 1.0, 1.5, 2.0, 2.5	$\pm (0.1 + \text{the selected measuring force}/10)$	within 0.1	300		
227-203-20	15 - 30									380		
227-205-20	0 - 10		2 - 10 (adjustable)							$\pm (0.4 + \text{the selected measuring force}/10)$	within 0.4	345
227-206-20	10 - 20											425
227-207-20	20 - 30											415

Inch / Metric												
Code No.	Range (in)	Resolution	Measuring force (N)	Maximum permissible error J_{MPE} (in)	Flatness (in)	Parallelism (in)	Measuring force (N)	Accuracy of the selected measuring force* (N)	Repeatability of measuring force* (N)	Mass (g)		
With SPC data output												
227-211-20	0 - 0.6	0.00005 in/ 0.001 mm	0.5 - 2.5 (adjustable)	± 0.0001	0.00012	0.00008	0.5, 1.0, 1.5, 2.0, 2.5	$\pm (0.1 + \text{the selected measuring force}/10)$	within 0.1	300		
227-213-20	0.6 - 1.2									380		
227-215-20	0 - 0.4		2 - 10 (adjustable)							$\pm (0.4 + \text{the selected measuring force}/10)$	within 0.4	345
227-216-20	0.4 - 0.8											425
227-217-20	0.8 - 1.2											415

- Measurement posture: horizontal orientation only (Recommended spindle inclination: within $\pm 3^\circ$)
- Power source: SR44 battery (1 pc.), **938882** included as standard (for operational checks)
- Battery life: Approx. 5 years under normal use
- Position detection method: Electrostatic capacity absolute sensor
- Standard accessories: Setting standard, 1 pc. (except for measuring range 0 to 15 mm (0 to 0.6 in)/0 to 10 mm (0 to 0.4 in) models), Screwdriver (**210183**), 1 pc.

* These values are guaranteed when micrometer is used in a horizontal orientation (within ± 3 degrees)

DIMENSIONS

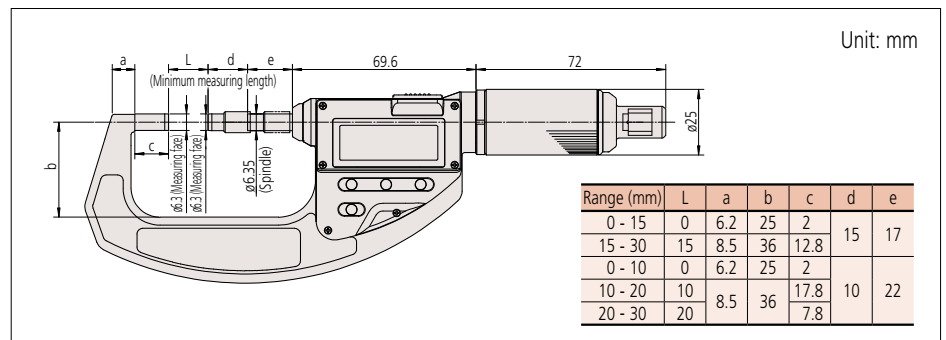

Micrometer

Outside Micrometers SERIES 406 — Non-rotating Spindle Type

- Non-rotating spindle eliminates torque on workpiece. Therefore, it is suitable for measuring flexible workpieces such as rubber and paper or thin workpieces such as film.
- Measuring faces: Carbide tipped
- Spindle $\phi 6.35$ mm
- Equipped with Ratchet Stop for constant measuring force.



406-250-30

SPECIFICATIONS

Metric					
Code No.	Range (mm)	Resolution (mm)	Maximum permissible error J_{MPE} (μ m)	Flatness (μ m)	Parallelism (μ m)
With SPC data output					
406-250-30	0 - 25	0.001	± 3	0.3	3
406-251-30	25 - 50				
406-252-30	50 - 75		± 4	4	
406-253-30	75 - 100				
Inch / Metric					
Code No.	Range (in)	Resolution	Maximum permissible error J_{MPE} (in)	Flatness (in)	Parallelism (in)
With SPC data output					
406-350-30	0 - 1	0.00005 in/ 0.001 mm	± 0.00015	0.000012	0.00012
406-351-30	1 - 2				
406-352-30	2 - 3		± 0.0002	0.00016	
406-353-30	3 - 4				

- Power source: SR44 battery (1 pc.). **938882** included as standard (for operational checks)
- Battery life: Approx. 2.4 years under normal use
- Position detection method: Electromagnetic rotary sensor
- Standard accessories: Setting standard, 1 pc. (except for measuring range 0 to 25 mm (0 to 1 in) models) Spanner (**301336**), 1 pc.

Note: For functional details of **series 406**, refer to page 02-7. Please note that these models are not water-proof.

DIMENSIONS

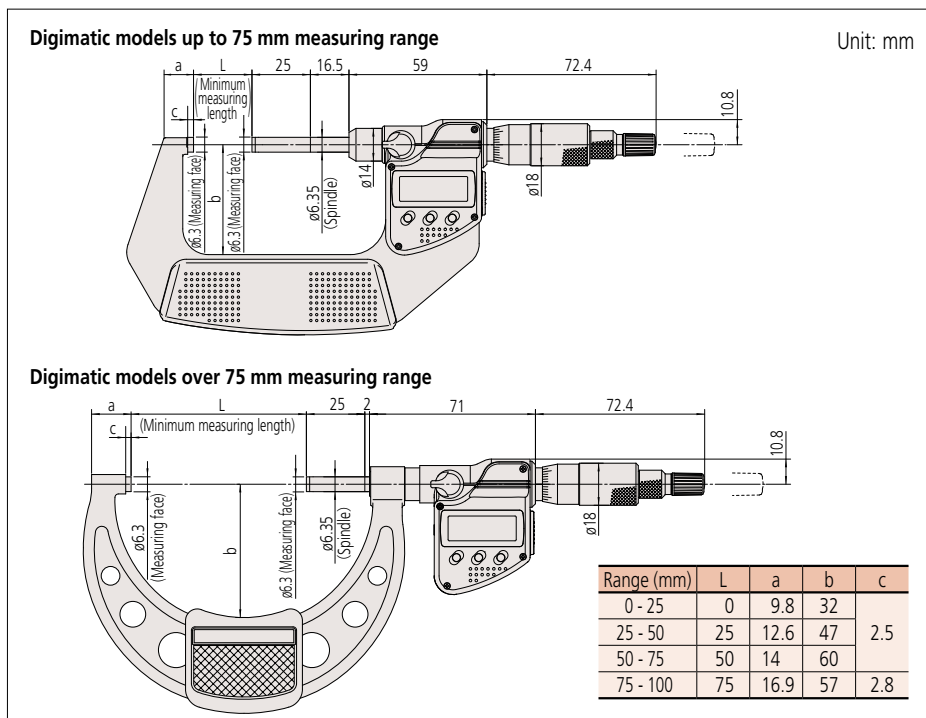

Measurement example



Optional Accessories

Code No.	Type	Description
264-020	—	USB Input Tool Series USB Keyboard Signal Conversion Type IT-020U
05CZA662	B	Connection cable (1 m)
05CZA663	B	Connection cable (2 m)
06AFM380B	B	USB Input Tool Direct (2 m)
02AZD730G	IP67	U-WAVE-T
02AZD880G	Buzzer	U-WAVE-T
02AZE200	—	U-WAVE-T mounting bracket
02AZD790B	B	Connection cable for U-WAVE-T (160 mm)
02AZE140B	B	Connection cable for U-WAVE-T For foot switch
264-622	IP67	U-WAVE-TM
264-623	Buzzer	U-WAVE-TM
264-626	IP67	U-WAVE-TMB
264-627	Buzzer	U-WAVE-TMB
02AZF310	IP67	Connecting unit for U-WAVE-TM/TMB



Applicable models:
340-251-30, 340-252-30, 340-351-30, 340-352-30

Measurement example



Optional Accessories

Code No.	Type	Description
264-020	—	USB Input Tool Series USB Keyboard Signal Conversion Type IT-020U
05CZA662	B	Connection cable for 340-251-30, 340-252-30, 340-351-30 and 340-352-30 (1 m)
05CZA663	B	Connection cable for 340-251-30, 340-252-30, 340-351-30 and 340-352-30 (2 m)
04AZB512	CR	Connection cable (1 m) for 340-5XX, 340-7XX
04AZB513	CR	Connection cable (2 m) for 340-5XX, 340-7XX
959149	C	Connection cable (1 m) for 340-5XX, 340-7XX
959150	C	Connection cable (2 m) for 340-5XX, 340-7XX
06AFM380B	B	USB Input Tool Direct (2 m)
06AFM380C	C	USB Input Tool Direct (2 m)
02AZD730G	IP67	U-WAVE-T
02AZD880G	Buzzer	U-WAVE-T
02AZD790B	B	Connection cable for U-WAVE-T (160 mm)
02AZE140B	B	Connection cable for U-WAVE-T For foot switch
02AZD790C	C	Connection cable for U-WAVE-T (160 mm)
02AZE140C	C	Connection cable for U-WAVE-T For foot switch
264-622	IP67	U-WAVE-TM*
264-623	Buzzer	U-WAVE-TM*
264-626	IP67	U-WAVE-TMB*
264-627	Buzzer	U-WAVE-TMB*
02AZF310	IP67	Connecting unit for U-WAVE-TM/TMB*

* Only 340-251-30, 340-252-30, 340-351-30 and 340-352-30 can be attached.

Outside Micrometers
SERIES 340 — with Interchangeable Anvils

- Wide measuring range with interchangeable anvils.
- Measuring face of the spindle is carbide tipped (standard model).
- IP65 water/dust protection.
- Equipped with Ratchet Stop for constant measuring force.



340-251-30



340-520

SPECIFICATIONS

Metric									
Code No.	Range (mm)	Resolution (mm)	Spindle feed error (μm)	Flatness (μm)	Parallelism (μm)	Interchangeable anvils	Setting Qty	Standard Size (mm)	Micrometer head stroke (mm)
With SPC data output									
340-251-30*	0 - 75	0.001	3	0.6	2	6 pcs.	5	25 - 125	25
	75 - 150								
340-252-30*	150 - 300				3		6	150 - 275	
340-520	300 - 400			1.0	6	4 pcs.	4	300 - 375	
340-521	400 - 500				7			400 - 475	
340-522	500 - 600			8	500 - 575				
340-523	600 - 700			9	600 - 675				
340-524	700 - 800			10	700 - 775				
340-525	800 - 900			11	800 - 875				
340-526	900 - 1000			12	900 - 975				

Inch / Metric									
Code No.	Range (in)	Resolution	Spindle feed error (in)	Flatness (in)	Parallelism (in)	Interchangeable anvils	Setting Qty	Standard Size (in)	Micrometer head stroke (in)
With SPC data output									
340-351-30*	0 - 6	0.00005 in/ 0.001 mm	0.00015	0.000024	0.00012	6 pcs.	5	1 - 5	1
340-352-30*	6 - 12	0.0001 in/ 0.001 mm						0.00004	
340-720	12 - 18				0.00036	12 - 17			
340-721	18 - 24			0.0004	18 - 23				
340-722	24 - 30			0.00044	24 - 29				
340-723	30 - 36				30 - 35				

- * IP65 model.
 - Power source for 340-251-30, 340-252-30, 340-351-30, 340-352-30: SR44 battery (1 pc.), 938882 included as standard (for operational checks)
 - Power source for 340-520 to 340-526, 340-720 to 340-723: SR44 battery (2 pcs.), 938882 included as standard (for operational checks)
 - Battery life: Approx. 2.4 years under normal use (for 340-2XX, 340-3XX)
Approx. 1.8 years under normal use (for 340-5XX, 340-7XX)
 - Position detection method: Electromagnetic rotary sensor (for series 340)
 - Standard accessories: Spanner (301336), 1 pc.
(for maximum measuring range up to 300 mm (12 in)), Spanner (200154), 1 pc.
(for maximum measuring range 400 mm (16 in) or over)
- Note 1: For functional details of 340-251-30, 340-252-30, 340-351-30, 340-352-30, refer to page 02-7.
Please note that origin setting of these models is by presetting.
Optional connection cable is available only for water-proof type (Digimatic model).
- Note 2: For functional details of 340-520 to 340-723, refer to page 02-9.

Micrometer

Outside Micrometers SERIES 340 — with Interchangeable Anvils

DIMENSIONS

Over 400 mm up to 1000 mm

Unit: mm

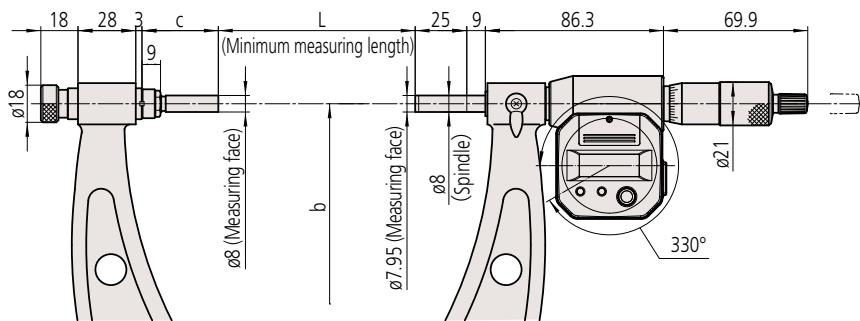

		L: Range (mm)				b
Range	300 - 400 mm models	300 - 325	325 - 350	350 - 375	375 - 400	224
Range	400 - 500 mm models	400 - 425	425 - 450	450 - 475	475 - 500	273
Range	500 - 600 mm models	500 - 525	525 - 550	550 - 575	575 - 600	332
Range	600 - 700 mm models	600 - 625	625 - 650	650 - 675	675 - 700	382
Range	700 - 800 mm models	700 - 725	725 - 750	750 - 775	775 - 800	430
Range	800 - 900 mm models	800 - 825	825 - 850	850 - 875	875 - 900	480
Range	900 - 1000 mm models	900 - 925	925 - 950	950 - 975	975 - 1000	530
Code No.	304001	304002	304003	304004		
c: Overall (mm)	87	62	37	12		
Interchangeable anvil	M3	M4	M5	M6		



Measurement example



Mechanism

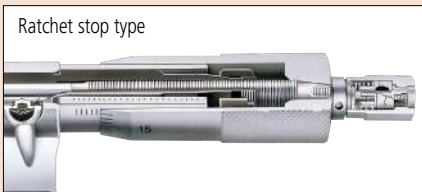

Micrometer with Vernier scale (graduation: 0.001 mm)

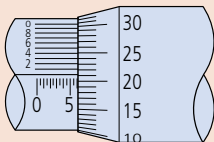

Outside Micrometers
SERIES 102

- Standard analog micrometer. Thanks to a heat-insulated frame, it is resistant to heat and therefore delivers accurate measurement results.

- Cut-away frame (behind anvil) for measuring in hard-to-reach places.
- Equipped with Ratchet Stop for constant measuring force.
- Measuring faces: Carbide tipped



Ratchet stop
102-301

SPECIFICATIONS

Metric							
Code No.	Range (mm)	Graduation (mm)	Measuring force (N)	Maximum permissible error J_{MPE} (μ m)	Flatness (μ m)	Parallelism (μ m)	Constant measuring force
102-301	0 - 25	0.01	5 - 10	± 2	0.6	2	Ratchet stop
102-302	25 - 50						
102-303	50 - 75						
102-304	75 - 100						

Metric With vernier scale							
Code No.	Range (mm)	Graduation (mm)	Measuring force (N)	Maximum permissible error J_{MPE} (μ m)	Flatness (μ m)	Parallelism (μ m)	Constant measuring force
102-311	0 - 25	0.001	5 - 10	± 1	0.3	1	Ratchet stop
102-313							Friction thimble
102-312	25 - 50			± 2			Ratchet stop

Inch							
Code No.	Range (in)	Graduation (in)	Measuring force (N)	Maximum permissible error J_{MPE} (in)	Flatness (in)	Parallelism (in)	Constant measuring force
102-327-10	0 - 1	0.0001	5 - 10	± 0.0001	0.000024	0.00008	Ratchet stop
102-329-10							Friction thimble
102-328-10	1 - 2						Ratchet stop
102-330-10							Friction thimble
102-331-10	2 - 3						Ratchet stop
102-332-10	3 - 4			± 0.00015		0.00012	Ratchet stop

Metric Micrometer set		
Code No.	Range (mm)	Models included
102-911-40	0 - 100 (Four micrometers per set)	<ul style="list-style-type: none"> • 102-301 • 102-302 • 102-303 • 102-304 • 3 micrometer standards

- Standard accessories: Setting standard, 1 pc. (except for measuring range 0 to 25 mm models)
- Spanner (301336), 1 pc. (for measuring range 0 to 25 mm/25 to 50 mm models)
- Spanner (200877), 1 pc. (for measuring range 50 to 75 mm/75 to 100 mm models)

DIMENSIONS

Range (mm)	L	a	b	c
0 - 25	0	5	26	2.5
25 - 50	25	7.8	32	
50 - 75	50	10.6	45	
75 - 100	75	11	58	

Micrometer



Ratchet Thimble Micrometer SERIES 102 — Outside Micrometers

- The ratchet thimble mechanism enables easy one-handed operation, useful for inspecting samples during the manufacturing process.
- Ratchet function works both from the thimble and the speeder.
- Clearly audible ratchet operation for reassurance that measurement is being performed at constant, preset force.
- Heat-insulated frame.
- Measuring faces: Carbide tipped



102-701

SPECIFICATIONS

Metric							
Code No.	Range (mm)	Graduation (mm)	Measuring force (N)	Maximum permissible error J_{MPE} (μ m)	Flatness (μ m)	Parallelism (μ m)	Mass (g)
102-701	0 - 25	0.01	5 - 10	± 2	0.6	2	180
102-707		0.001					
102-702	25 - 50	0.01					
102-708		0.001					270

Inch							
Code No.	Range (in)	Graduation (in)	Measuring force (N)	Maximum permissible error J_{MPE} (in)	Flatness (in)	Parallelism (in)	Mass (g)
102-717	0 - 1	0.0001	5 - 10	± 0.0001	0.000024	0.00008	180
102-718	1 - 2						270

• Standard accessories: Setting standard, 1 pc. (except for measuring range 0 to 25 mm (0 to 1 in) models), Spanner (301336), 1 pc.

Measurement example



Internal structure

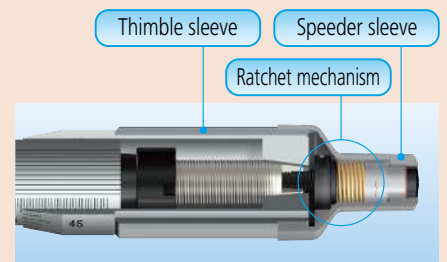

DIMENSIONS

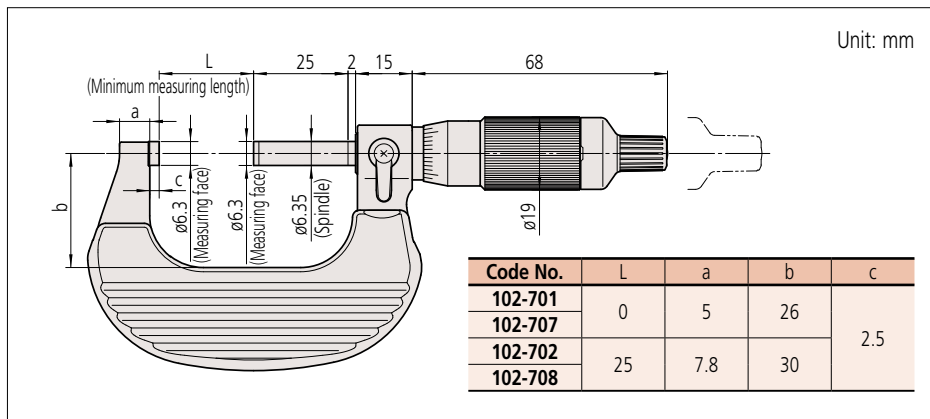



Measurement example



103-913-40

- Range: 0 - 150 mm (6 pcs./set)
- Models included: 103-137, 103-138, 103-139, 103-140, 103-141, 103-142, 5 micrometer standards



103-914-40

- Range: 0 - 300 mm (12 pcs./set)
- Models included: 103-137, 103-138, 103-139, 103-140, 103-141, 103-142, 103-143, 103-144, 103-145, 103-146, 103-147, 103-148, 11 micrometer standards



103-915

- Range: 150 - 300 mm (6 pcs./set)
- Models included: 103-143, 103-144, 103-145, 103-146, 103-147, 103-148, 6 micrometer standards

103-927-10

- Range: 0 - 75 mm (3 pcs./set)
- Models included: 103-137, 103-138, 103-139-10

103-913-50

- Range: 50 - 150 mm (6 pcs./set)
- Models included: 103-137, 103-138, 103-139-10, 103-140-10, 103-141-10, 103-142-10

103-914-50

- Range: 50 - 300 mm (12 pcs./set)
- Models included: 103-137, 103-138, 103-139-10, 103-140-10, 103-141-10, 103-142-10, 103-143-10, 103-144-10, 103-145-10, 103-146-10, 103-147-10, 103-148-10

103-915-10

- Range: 150 - 300 mm (6 pcs./set)
- Models included: 103-143-10, 103-144-10, 103-145-10, 103-146-10, 103-147-10, 103-148-10

Outside Micrometers
SERIES 103

- This is a simple, classic analog micrometer that represents the roots of our company's foundation.
- Measuring faces: Carbide tipped
- Equipped with Ratchet Stop for constant measuring force.



Metric		With ratchet stop				
Code No.	Range (mm)	Measuring force (N)	Graduation (mm)	MPE*1 (µm)	Flatness (µm)	Parallelism (µm)
103-129	0 - 25	5 - 10	0.001	±2	0.6	2
103-130	25 - 50					
103-139-10	50 - 75					
103-140-10	75 - 100			±3		
103-141-10	100 - 125					
103-142-10	125 - 150					
103-143-10	150 - 175			±4		
103-144-10	175 - 200					
103-145-10	200 - 225					
103-146-10	225 - 250			±5		
103-147-10	250 - 275					
103-148-10	275 - 300					
103-149	300 - 325	10 - 15	0.01	±6	1	5
103-150	325 - 350					
103-151	350 - 375					
103-152	375 - 400					
103-153	400 - 425					
103-154	425 - 450					
103-155	450 - 475					
103-156	475 - 500					
103-157	500 - 525					
103-158	525 - 550					
103-159	550 - 575					
103-160	575 - 600					
103-161	600 - 625					
103-162	625 - 650					
103-163	650 - 675					
103-164	675 - 700					
103-165	700 - 725					
103-166	725 - 750					
103-167	750 - 775					
103-168	775 - 800					
103-169	800 - 825					
103-170	825 - 850					
103-171	850 - 875					
103-172	875 - 900					
103-173	900 - 925					
103-174	925 - 950					
103-175	950 - 975					
103-176	975 - 1000					

Metric		With ratchet stop				
Code No.	Range (mm)	Measuring force (N)	Graduation (mm)	MPE*1 *2 (µm)	Flatness (µm)	Parallelism (µm)
103-137	0 - 25	5 - 10	0.01	±2	0.6	2
103-138	25 - 50					
103-255	50 - 75					
103-256	75 - 100		0.001	±3		
103-257	100 - 125					
103-258	125 - 150					

• Standard accessories: Setting standard, 1 pc. (except for measuring range 0 to 25 mm (0 to 1 in) models), Spanner (301336), 1 pc. (for maximum measuring range up to 300 mm (12 in)), Spanner (200154), 1 pc. (for maximum measuring range 325 mm (13 in) or over)
 *1 MPE: Maximum permissible error J_{MPE}
 *2 Maximum permissible error of the indication measured by contacting the full measuring face with the object to be measured. J_{MPE} is a term specified by JIS B 7502: 2016 which has been prepared based on ISO 3611: 2010 with some modifications of the technical contents. The measurement method has not been changed from JIS B 7502: 1994. For details refer to page 13-10.

Micrometer

Inch With ratchet stop										
Code No.	Range (in)	Measuring force (N)	Graduation (in)	MPE*1 (in)	Flatness (in)	Parallelism (in)				
103-177	0 - 1	5 - 10	0.001	±0.0001	0.000024	0.00008				
103-131			0.0001							
103-178	1 - 2		0.001							
103-132			0.0001							
103-179	2 - 3		±0.00015	0.000024		0.00012				
103-180	3 - 4									
103-181	4 - 5									
103-182	5 - 6									
103-183	6 - 7									
103-184	7 - 8									
103-185	8 - 9									
103-186	9 - 10									
103-187	10 - 11									
103-188	11 - 12									
103-189	12 - 13						0.001	0.00004	0.00004	0.0002
103-190	13 - 14									
103-191	14 - 15									
103-192	15 - 16									
103-193	16 - 17									
103-194	17 - 18									
103-195	18 - 19									
103-196	19 - 20									
103-197	20 - 21									
103-198	21 - 22									
103-199	22 - 23									
103-200	23 - 24									
103-201	24 - 25									
103-202	25 - 26									
103-203	26 - 27									
103-204	27 - 28									
103-205	28 - 29									
103-206	29 - 30									
103-207	30 - 31									
103-208	31 - 32									
103-209	32 - 33									
103-210	33 - 34									
103-211	34 - 35									
103-212	35 - 36									
103-213	36 - 37									
103-214	37 - 38									
103-215	38 - 39									
103-216	39 - 40	±0.00075	0.00004	0.00036	0.0004					
103-259	0 - 1									
103-217	2 - 3									
103-218	3 - 4									
103-219	4 - 5									
103-220	5 - 6									
103-221	6 - 7									
103-222	7 - 8									
103-223	8 - 9									
103-224	9 - 10									
103-225	10 - 11									
103-226	11 - 12									

Inch With friction thimble						
Code No.	Range (in)	Measuring force (N)	Graduation (in)	MPE*1 *2(in)	Flatness (in)	Parallelism (in)
103-135	0 - 1	5 - 10	0.0001	±0.0001	0.000024	0.00008
103-136	1 - 2					

• Standard accessories: Setting standard, 1 pc. (except for measuring range 0 to 25 mm (0 to 1 in) models)- (301336), 1 pc. (for maximum measuring range up to 300 mm (12 in)), Spanner (200154), 1 pc. (for maximum measuring range 325 mm (13 in) or over)

*1 MPE: Maximum permissible error J_{MPE}

*2 Maximum permissible error of the indication measured by contacting the full measuring face with the object to be measured. J_{MPE} is a term specified by JIS B 7502: 2016 which has been prepared based on ISO 3611: 2010 with some modifications of the technical contents. The measurement method has not been changed from JIS B 7502: 1994. For details refer to page 13-10.



103-904-10

- Range: 0 - 6 in (6 pcs./set)
- Models included: 103-177, 103-178, 103-179, 103-180, 103-181, 103-182, 5 micrometer standards



103-905-10

- Range: 0 - 12 in (12 pcs./set)
- Models included: All micrometers of 103-904-10 and 103-906 in one set, 11 micrometer standards



103-906

- Range: 6 - 12 in (6 pcs./set)
- Models included: 103-183, 103-184, 103-185, 103-186, 103-187, 103-188, 6 micrometer standards

103-907-40

- Range: 0 - 6 in (6 pcs./set)
- Models included: 103-135, 103-136, 103-217, 103-218, 103-219, 103-220

103-908-40

- Range: 0 - 12 in (12 pcs./set)
- Models included: 103-135, 103-136, 103-217, 103-218, 103-219, 103-220, 103-221, 103-222, 103-223, 103-224, 103-225, 103-226

103-909

- Range: 6 - 12 in (6 pcs./set)
- Models included: 103-221, 103-222, 103-223, 103-224, 103-225, 103-226

103-929

- Range: 0 - 3 in (3 pcs./set)
- Models included: 103-177, 103-178, 103-179

103-930

- Range: 0 - 4 in (4 pcs./set)
- Models included: 103-177, 103-178, 103-179, 103-180

Outside Micrometers SERIES 103

DIMENSIONS

103-137 and 103-138, Models 75 mm to 300 mm

Unit: mm

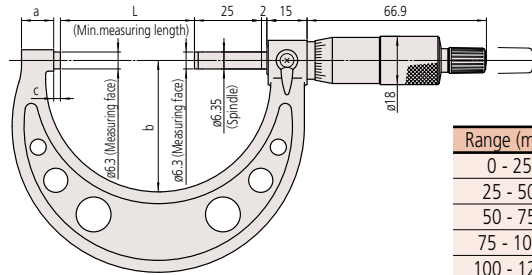

Range (mm)	L	a	b	c
0 - 25	0	9	28	2.5
25 - 50	25	10	38	
50 - 75	50	12	49	
75 - 100	75	14	60	
100 - 125	100	16.7	79	5.3
125 - 150	125	18.8	94	5.7
150 - 175	150	19.1	106	6.1
175 - 200	175	18.2	118	6.3
200 - 225	200	16.8	130	6.7
225 - 250	225	18	143	5.5
250 - 275	250		156	6.5
275 - 300	275		169	

DIMENSIONS

Models 325 mm to 1000 mm

Unit: mm

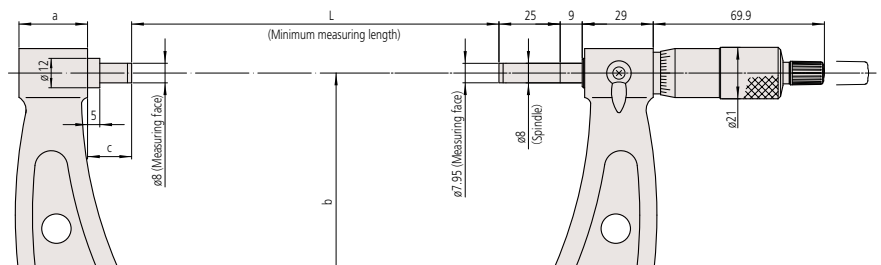

Range (mm)	L	a	b	c	
300 - 325	300	28	187	18	
325 - 350	325		199		
350 - 375	350		212		
375 - 400	375		224		
400 - 425	400		236		
425 - 450	425		248		
450 - 475	450		261		
475 - 500	475		273		
500 - 525	500		307		40
525 - 550	525				15
550 - 575	550		332		40
575 - 600	575				15
600 - 625	600		355		40
625 - 650	625				15

Range (mm)	L	a	b	c
650 - 675	650	28	382	40
675 - 700	675			15
700 - 725	700		405	40
725 - 750	725			15
750 - 775	750		430	40
775 - 800	775			15
800 - 825	800		455	40
825 - 850	825			15
850 - 875	850		480	40
875 - 900	875			15
900 - 925	900		505	40
925 - 950	925			15
950 - 975	950		530	40
975 - 1000	975			15

Micrometer

Digit Outside Micrometers SERIES 193

- Mechanical digit counter with 0.01 mm or 0.001 in resolution for quick and error-free reading.
- Counter resolution 0.01 mm
- Measuring faces: Carbide tipped
- Equipped with Ratchet Stop for constant measuring force.



193-101

SPECIFICATIONS

Metric With ratchet stop					
Code No.	Range (mm)	Maximum permissible error J_{MPE} (μm)	Flatness (μm)	Parallelism (μm)	Graduation (mm)
193-111	0 - 25	±2	0.6	2	0.001 (reading is obtained with vernier)
193-112	25 - 50				
193-113	50 - 75				
193-114	75 - 100	±3		3	0.01
193-101	0 - 25	±2		2	
193-102	25 - 50				
193-103	50 - 75				
193-104	75 - 100	±3	3		

Inch With friction thimble					
Code No.	Range (in)	Maximum permissible error J_{MPE} (in)	Flatness (in)	Parallelism (in)	Graduation (in)
193-211	0 - 1	±0.0001	0.000024	0.00008	0.0001
193-212	1 - 2				

Inch With ratchet stop					
Code No.	Range (in)	Maximum permissible error J_{MPE} (in)	Flatness (in)	Parallelism (in)	Graduation (in)
193-213	2 - 3	±0.0001	0.000024	0.00008	0.0001
193-214	3 - 4	±0.00015		0.00012	

Metric Micrometer set				
Code No.	Range (mm)	Models included	Flatness (μm)	Parallelism (μm)
193-901	0 - 75 (3 pcs./set)	• 193-101, 193-102, 193-103 • 2 micrometer standards	0.6	2
193-902	0 - 100 (4 pcs./set)	• 193-101, 193-102, 193-103, 193-104 • 3 micrometer standards		3

Inch Micrometer set				
Code No.	Range (in)	Models included	Flatness (in)	Parallelism (in)
193-923	0 - 3 (3 pcs./set)	• 193-211, 193-212, 193-213 • 2 micrometer standards	0.000024	0.00008

• Standard accessories: Setting standard, 1 pc. (except for measuring range 0 to 25 mm (0 to 1 in) models), Spanner (301336), 1 pc.

Measurement example



- 193-901**
- Range: 0 - 75 mm
 - Graduation: 0.01 mm
 - Models included: 193-101, 193-102, 193-103
2 micrometer standards



- 193-902**
- Range: 0 - 100 mm
 - Graduation: 0.01 mm
 - Models included: 193-101, 193-102, 193-103, 193-104
3 micrometer standards

Digit Outside Micrometers SERIES 193

DIMENSIONS

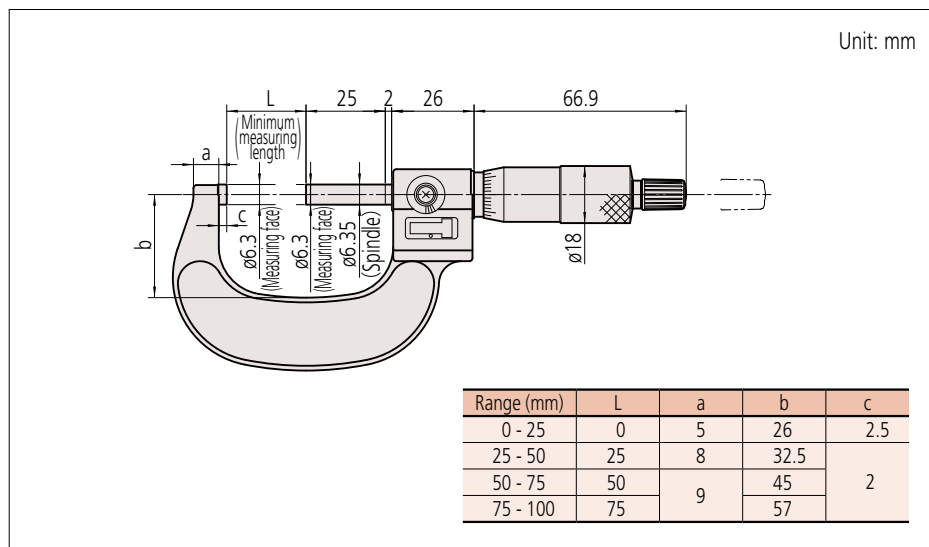

DIMENSIONS

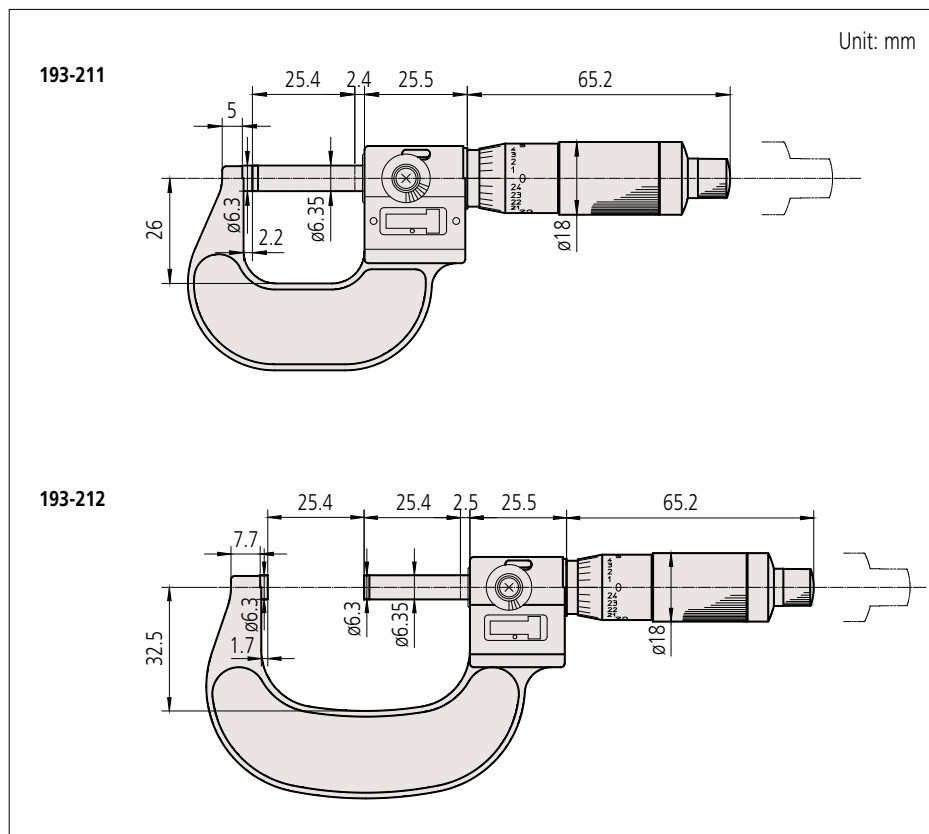

Micrometer

Outside Micrometers SERIES 104 — with Interchangeable Anvils

- Wide measuring range with interchangeable anvils.
- Measuring face of the spindle is carbide tipped (standard model).
- Equipped with Ratchet Stop for constant measuring force.



SPECIFICATIONS

Metric										
Code No.	Range (mm)	Graduation (mm)	Spindle feed error (μm)	Flatness (μm)	Parallelism (μm)	Interchangeable anvils	Setting Qty	Standard Size (mm)	Micrometer head stroke (mm)	
Analog										
104-171*	0 - 50	0.01	3	0.6	2	1 pc.	1	25	25	
104-139A	0 - 100				3	4 pcs.	3	25 - 75		
104-135A	0 - 150					6 pcs.	5	25 - 125		
104-161A	50 - 150				4	4 pcs.	4	50 - 125		
104-140A	100 - 200					6 pcs.	6	100 - 175		
104-136A	150 - 300				1.0	5	4 pcs.	4		6
104-141A	200 - 300			6		200 - 275				
104-142A	300 - 400			7		300 - 375				
104-143A	400 - 500			8		400 - 475				
104-144A	500 - 600			9		500 - 575				
104-145A	600 - 700			10		600 - 675				
104-146A	700 - 800			11	700 - 775					
104-147A	800 - 900	12	800 - 875							
104-148A	900 - 1000						900 - 975			
Inch										
Code No.	Range (in)	Graduation (in)	Spindle feed error (in)	Flatness (in)	Parallelism (in)	Interchangeable anvils	Setting Qty	Standard Size (in)	Micrometer head stroke (in)	
Analog										
104-165	0 - 2	0.0001	0.00015	0.000024	0.00008	1 pc.	1	1	1	
104-149	0 - 4				0.00012	4 pcs.	3	1 - 3		
104-137	0 - 6					6 pcs.	5	1 - 5		
104-162	2 - 6				0.00016	4 pcs.	4	2 - 5		
104-150	4 - 8					6 pcs.	6	4 - 7		
104-138	6 - 12				0.0002	4 pcs.	4	6 - 11		
104-151	8 - 12			6 pcs.		6	8 - 11			
104-152	12 - 16			0.00024	4 pcs.	4	12 - 15			
104-201	12 - 18				6 pcs.	6	12 - 17			
104-153	16 - 20				4 pcs.	4	16 - 19			
104-202	18 - 24				6 pcs.	6	18 - 23			
104-154	20 - 24				0.00032	4 pcs.	4	20 - 23		
104-155	24 - 28	6 pcs.	6			24 - 27				
104-203	24 - 30	0.00036	6 pcs.	6	24 - 29					
104-156	28 - 32		4 pcs.	4	28 - 31					
104-204	30 - 36	0.00044	6 pcs.	6	30 - 35					
104-157	32 - 36		4 pcs.	4	32 - 35					
104-158	36 - 40	0.00048	6 pcs.	6	36 - 39					
104-205	36 - 42		4 pcs.	4	36 - 41					

* The frame is fitted with a heat shield.

Outside Micrometers SERIES 104 — with Interchangeable Anvils

DIMENSIONS

Unit: mm

104-135A

Interchangeable Anvil

		L: Range (mm)					
Range	0 - 150 mm models	0 - 25	25 - 50	50 - 75	75 - 100	100 - 125	125 - 150
Range	150 - 300 mm models	150 - 175	175 - 200	200 - 225	225 - 250	250 - 275	275 - 300
	Code No.	303950	303951	303952	303953	303954	303955
	c: Overall length (mm)	135	110	85	60	35	10
	Interchangeable anvil	M1	M2	M3	M4	M5	M6

		L: Range (mm)			
Range	300 - 400 mm models	300 - 325	325 - 350	350 - 375	375 - 400
Range	400 - 500 mm models	400 - 425	425 - 450	450 - 475	475 - 500
Range	500 - 600 mm models	500 - 525	525 - 550	550 - 575	575 - 600
Range	600 - 700 mm models	600 - 625	625 - 650	650 - 675	675 - 700
Range	700 - 800 mm models	700 - 725	725 - 750	750 - 775	775 - 800
Range	800 - 900 mm models	800 - 825	825 - 850	850 - 875	875 - 900
Range	900 - 1000 mm models	900 - 925	925 - 950	950 - 975	975 - 1000
	Code No.	304001	304002	304003	304004
	c: Overall length (mm)	87	62	37	12
	Interchangeable anvil	M3	M4	M5	M6

Micrometer

Outside Micrometers SERIES 105 — with Anvil Extension Collars

- Adjustable measuring range with extension collars.
- 50 mm/2 in spindle stroke.
- Measuring faces: Carbide tipped
- Equipped with Ratchet Stop for constant measuring force.



Extension collar



Measuring range 700 to 750 mm with **105-105**



Measuring range 750 to 800 mm with **105-105**

SPECIFICATIONS

Metric							
Code No.	Range (mm)	Graduation (mm)	Extension Collars	Setting Standard	Spindle feed error (μm)	Flatness (μm)	Parallelism (μm)
105-103	500 - 600	0.01	1 pc. (50 mm)	2 pcs.	6	1.3	8
105-104	600 - 700						9
105-105	700 - 800						10
105-106	800 - 900						11
105-107	900 - 1000						12

- Standard Accessories: Spanner (**200154**), 1 pc.

Outside Micrometers SERIES 105 — with Anvil Extension Collars

Measurement example



- Square and round pipes are combined to create a lightweight, rigid frame.
- Wide measuring range with anvil extension collars.
- 50 mm/2 in spindle stroke.
- Includes workpiece stopper.
- Measuring faces: Carbide tipped
- Equipped with Ratchet Stop for constant measuring force.

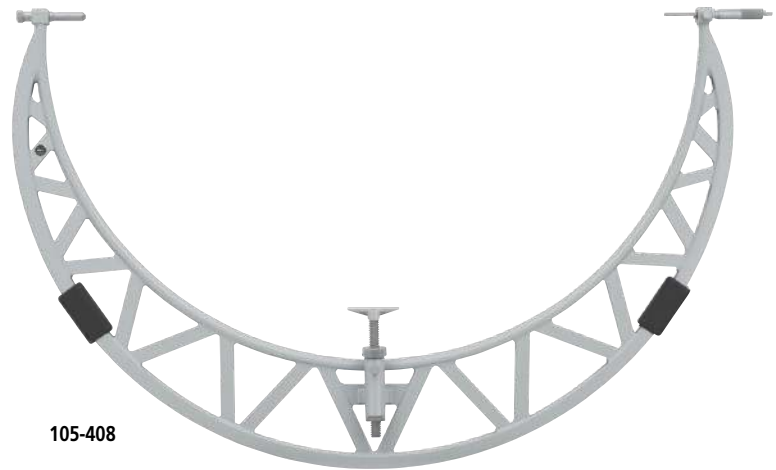

105-408

SPECIFICATIONS

Metric							
Code No.	Range (mm)	Graduation (mm)	Extension Collars	Setting Standard (pcs.)	Spindle feed error (μm)	Flatness (μm)	Parallelism (μm)
(every 100 mm)							
105-408	1000 - 1100	0.01	1 pc. (50 mm)	2	6	1.3	13
105-409	1100 - 1200						14
105-410	1200 - 1300						15
105-411	1300 - 1400						16
105-412	1400 - 1500						17
105-413	1500 - 1600						18
105-414	1600 - 1700						19
105-415	1700 - 1800						20
105-416	1800 - 1900						21
105-417	1900 - 2000						22
(every 200 mm)							
105-418	1000 - 1200	0.01	2 pcs. (50 mm, 100 mm)	4 (every 50 mm)	6	1.3	14
105-419	1200 - 1400						16
105-420	1400 - 1600						18
105-421	1600 - 1800						20
105-422	1800 - 2000						22
Inch							
Code No.	Range (in)	Graduation (in)	Extension Collars	Setting Standard (pcs.)	Spindle feed error (in)	Flatness (in)	Parallelism (in)
105-428	40 - 44	0.001	1 pc. (2 in)	2	0.0003	0.000052	0.00052
105-429	44 - 48						0.00056
105-430	48 - 52						0.00060
105-431	52 - 56						0.00064
105-432	56 - 60						0.00068
105-433	60 - 64						0.00072
105-434	64 - 68						0.00076
105-435	68 - 72						0.00080
105-436	72 - 76						0.00084
105-437	76 - 80						0.00088

• Standard Accessories: Spanner (200154), 1 pc.

Micrometer

DIMENSIONS

Over 1200 mm up to 2000 mm

Unit: mm

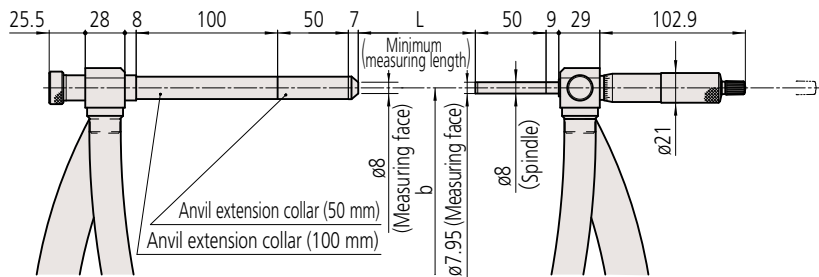

b: distance to workpiece stop

Range (mm)	L	b
1000 - 1200	1000	500 - 600
1200 - 1400	1200	600 - 700
1400 - 1600	1400	700 - 800
1600 - 1800	1600	800 - 900
1800 - 2000	1800	900 - 1000

Indicator Type Micrometers SERIES 107

Measurement example



Typical indicator choice

- Dial indicator (0.01 mm): **2046AB**
- Dial indicator (0.001 mm): **2109AB-10**
- ABS Digimatic Indicator (0.01 mm): **543-710B**
- ABS Digimatic Indicator (0.0005 mm): **543-700B**

- Designed to mount a dial indicator for direct GO/±NG judgment for mass-produced parts.
- Anvil retracting trigger for quick measurement.

- Various kinds of indicators* are available depending on the measurement type (accuracy required, measuring range, etc.).
- Measuring faces: Carbide tipped
- Anvil stroke: 3 mm

* Only stems of ø8 diameter are supported, but even these may not be supported by some models. Please contact our Customer Support Center or your nearest Mitutoyo sales office for detailed specifications.



SPECIFICATIONS

Metric				
Code No.	Range (mm)	Spindle feed error (μm)	Flatness (μm)	Parallelism (μm)
107-201	0 - 25	3	0.6	2
107-202	25 - 50			
107-203	50 - 75			
107-204	75 - 100			
107-205	100 - 125			3
107-206	125 - 150			
107-207	150 - 175			
107-208	175 - 200			

- Setting standard, 1 pc. (except for measuring range 0 to 25 mm models), Spanner (**301336**), 1 pc.

DIMENSIONS

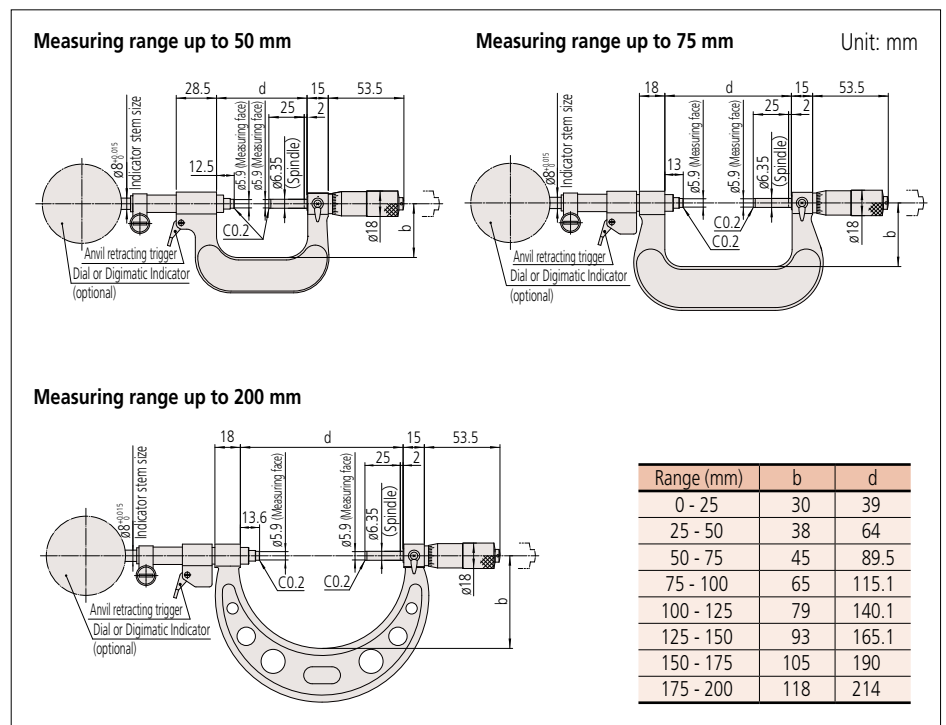

Micrometer

Caliper Type Micrometers SERIES 343

- Effective for measuring workpiece features where access is difficult with a standard micrometer.
- Measuring faces: Carbide tipped
- Equipped with Ratchet Stop for constant measuring force.



343-250-30

SPECIFICATIONS

Metric					
Code No.	Range (mm)	Resolution (mm)	Maximum permissible error J_{MPE} (μ m)	Flatness (μ m)	Parallelism (μ m)
With SPC data output					
343-250-30	0 - 25	0.001	± 5	0.3	3
343-251-30	25 - 50		± 6		
343-252-30	50 - 75		± 7		
343-253-30	75 - 100		± 8		4

Inch / Metric					
Code No.	Range (in)	Graduation (in)	Maximum permissible error J_{MPE} (in)	Flatness (in)	Parallelism (in)
With SPC data output					
343-350-30	0 - 1	0.0005 in/ 0.001 mm	± 0.00025	0.00012	0.00012
343-351-30	1 - 2		± 0.0003		
343-352-30	2 - 3		± 0.00035		0.00016
343-353-30	3 - 4		± 0.0004		

- Power source: SR44 battery (1 pc.), **938882** included as standard (for operational checks)
 - Battery life: Approx. 2.4 years under normal use
 - Position detection method: Electromagnetic rotary sensor
 - Standard accessories: Setting standard, 1 pc. (except for measuring range 0 to 25 mm (0 to 1 in) models), Spanner (**301336**), 1 pc.
- Note: For functional details of **series 343**, refer to page 02-7.
Please note that these models are not water-proof.

DIMENSIONS

Digimatic
Measuring range up to 100 mm

Unit: mm

Range (mm)	L	a	b	C
Digimatic (LCD)				
0 - 25	0	16	11.1	32.9
25 - 50	25			
50 - 75	50			
75 - 100	75			

Measurement example

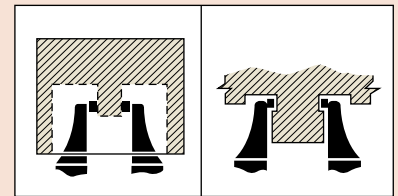

Optional Accessories (for series 343)

Code No.	Type	Description
264-020	—	USB Input Tool Series USB Keyboard Signal Conversion Type IT-020U
05CZA662	B	Connection cable (1 m)
05CZA663	B	Connection cable (2 m)
06AFM380B	B	USB Input Tool Direct (2 m)
02AZD730G	IP67	U-WAVE-T
02AZD880G	Buzzer	U-WAVE-T
02AZE200	—	U-WAVE-T mounting bracket
02AZD790B	B	Connection cable for U-WAVE-T (160 mm)
02AZE140B	B	Connection cable for U-WAVE-T For foot switch
264-622	IP67	U-WAVE-TM
264-623	Buzzer	U-WAVE-TM
264-626	IP67	U-WAVE-TMB
264-627	Buzzer	U-WAVE-TMB
02AZF310	IP67	Connecting unit for U-WAVE-TM/TMB

Micrometer

Screw Thread Micrometers SERIES 125

- Directly indicates screw pitch diameter (no need for calculation).
- Fixed anvil type. Select the right model to meet the specifications of your screw thread.
- Equipped with Ratchet Stop for constant measuring force.
- Supplied with a setting standard for adjusting zero point for metric (unified) 60° threads.



125-103

Measurement example



SPECIFICATIONS

Metric				
Code No.	Thread to be measured (Metric/Unified)	Range (mm)	Spindle feed error (μm)	Graduation (mm)
125-101	0.4 - 0.5 mm/64 - 48 TPI	0 - 25	3	0.01
125-102	0.6 - 0.9 mm/44 - 28 TPI			
125-103	1 - 1.75 mm/24 - 14 TPI			
125-104	2 - 3 mm/13 - 9 TPI			
125-105	3.5 - 5 mm/8 - 5 TPI			
125-106	0.4 - 0.5 mm/64 - 48 TPI	25 - 50		
125-107	0.6 - 0.9 mm/44 - 28 TPI			
125-108	1 - 1.75 mm/24 - 14 TPI			
125-109	2 - 3 mm/13 - 9 TPI			
125-110	3.5 - 5 mm/8 - 5 TPI	50 - 75		
125-111	0.6 - 0.9 mm/44 - 28 TPI			
125-112	1 - 1.75 mm/24 - 14 TPI			
125-113	2 - 3 mm/13 - 9 TPI			
125-114	3.5 - 5 mm/8 - 5 TPI			
125-115	5.5 - 7 mm/4.5 - 3.5 TPI	75 - 100		
125-116	0.6 - 0.9 mm/44 - 28 TPI			
125-117	1 - 1.75 mm/24 - 14 TPI			
125-118	2 - 3 mm/13 - 9 TPI			
125-119	3.5 - 5 mm/8 - 5 TPI			
125-120	5.5 - 7 mm/4.5 - 3.5 TPI			

• Standard Accessories: Spanner (301336), 1 pc.
 Note: A matching setting standard is supplied with each model (except for 0 to 25 mm measuring range). (Refer to page 02-73 for details.) The setting standard is for metric threads (unified) 60°.

DIMENSIONS

125-101, 125-106

Range (mm)	L	a	b
0 - 25	0	13.8	25
25 - 50	25		32

125-111, 125-116

Range (mm)	L	a	b
50 - 75	50	12	49
75 - 100	75	14	63

Unit: mm



Applicable models: series 326

Measurement example



Optional Accessories (for series 326)

Code No.	Type	Description
264-020	—	USB Input Tool Series USB Keyboard Signal Conversion Type IT-020U
05CZA662	B	Connection cable (1 m)
05CZA663	B	Connection cable (2 m)
06AFM380B	B	USB Input Tool Direct (2 m)
02AZD790B	B	Connection cable for U-WAVE-T (160 mm)
02AZE140B	B	Connection cable for U-WAVE-T For foot switch
264-622	IP67	U-WAVE-TM
264-623	Buzzer	U-WAVE-TM
264-626	IP67	U-WAVE-TMB
264-627	Buzzer	U-WAVE-TMB
02AZF310	IP67	Connecting unit for U-WAVE-TM/TMB

• For Metric/Unified threads (pair)

Code No.	Matching anvils/spindle tips included (mm)
126-801	0.4 - 0.5/64 - 48 TPI
126-802	0.6 - 0.9/44 - 28 TPI
126-803	1 - 1.75/24 - 14 TPI
126-804	2 - 3/13 - 9 TPI
126-805	3.5 - 5/8 - 5 TPI
126-806	5.5 - 7/4.5 - 3.5 TPI
126-800	Set with one each of 126-801 to 126-806

• For Whitworth threads (pair)

Code No.	Matching anvils/spindle tips included (mm)	Code No.	Matching anvils/spindle tips included (mm)
126-811	64 - 48 TPI	126-817	14 - 10 TPI
126-812	48 - 40 TPI	126-818	10 - 7 TPI
126-813	40 - 32 TPI	126-819	7 - 4.5 TPI
126-814	32 - 24 TPI	126-820	4.5 - 3.5 TPI
126-815	24 - 18 TPI	126-810	Set with one each of 126-811 to 126-820
126-816	18 - 14 TPI		

Screw Thread Micrometers
SERIES 326, 126 — Interchangeable Anvil/Spindle Tip Type

- This is a screw thread micrometer with changeable anvil and spindle tips. It enables direct reading of screw pitch diameter. Both analog and digital types are available.
- Interchangeable anvil and spindle tips are optional. Select the right model to meet the specifications of your screw thread.
- Equipped with Ratchet Stop for constant measuring force.
- Supplied with a setting standard for adjusting zero point for metric (unified) 60° threads.

Interchangeable anvils/
spindle tips (optional)



326-251-30



SPECIFICATIONS

Metric			
Code No.	Range (mm)	Resolution (mm)	Spindle feed error (μm)
With SPC data output			
326-251-30	0 - 25	0.001	3
326-252-30	25 - 50		
326-253-30	50 - 75		
326-254-30	75 - 100		

Inch / Metric			
Code No.	Range (in)	Resolution	Spindle feed error (in)
With SPC data output			
326-351-30	0 - 1	0.00005 in/ 0.001 mm	0.00015
326-352-30	1 - 2		
326-353-30	2 - 3		
326-354-30	3 - 4		

- Power source: SR44 battery (1 pc.), **938882** included as standard (for operational checks)
- Battery life: Approx. 2.4 years under normal use
- Position detection method: Electromagnetic rotary sensor
- Standard Accessories: Spanner (**301336**), 1 pc.

Note 1: A matching setting standard is supplied with each model (except for 0 to 25 mm measuring range). (Refer to page 02-73 for details.) The setting standard is for metric threads (unified) 60°.

Note 2: For functional details, refer to page 02-7. Please note that origin setting of these models is by presetting. Optional connection cable is available only for water-proof type (Digimatic model).



126-125

SPECIFICATIONS

Metric			
Code No.	Range (mm)	Graduation (mm)	Spindle feed error (μm)
126-125	0 - 25	0.01	3
126-126	25 - 50		
126-127	50 - 75		
126-128	75 - 100		
126-129	100 - 125		
126-130	125 - 150		
126-131	150 - 175		
126-132	175 - 200		
126-133	200 - 225		
126-134	225 - 250		
126-135	250 - 275		
126-136	275 - 300		

Inch			
Code No.	Range (in)	Graduation (in)	Spindle feed error (in)
126-137	0 - 1	0.001	0.00015
126-138	1 - 2		
126-139	2 - 3		
126-140	3 - 4		
126-141	4 - 5		
126-142	5 - 6		
126-143	6 - 7		
126-901	0 - 1		
126-902	1 - 2		
126-903	2 - 3		
126-904	3 - 4		
126-905	4 - 5		
126-906	5 - 6		

• Standard Accessories: Spanner (**301336**), 1 pc.

Note: A matching setting standard is supplied with each model (except for 0 to 25 mm measuring range). (Refer to page 02-73 for details.) The setting standard is for metric threads (unified) 60°.

Micrometer

Screw Thread Micrometers

SERIES 326, 126 — Interchangeable Anvil/Spindle Tip Type

DIMENSIONS

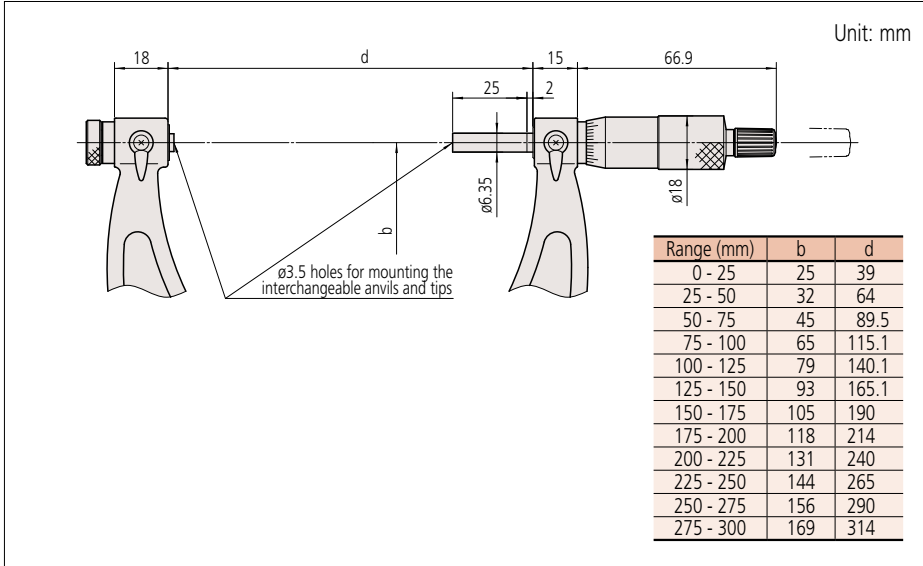

Technical description

- Anvils/spindle tips

- Allowable error of the angle of anvils and spindle tips

Type	Metric (Unified)	Whitworth (Unified)	Half angle error α
Pitch (mm), Nominal designation of threads per inch		W1	$\pm 30'$
	M1 (U1)	W2	$\pm 30'$
		W3	$\pm 20'$
	M2 (U2)	W4	$\pm 20'$
		W5	$\pm 15'$
	M3 (U3)	W6	$\pm 15'$
	M4 (U4)	W7	$\pm 10'$
		W8	$\pm 10'$
	M5 (U5)	W9	$\pm 10'$
	M6 (U6)	W10	$\pm 10'$

Note: This chart indicates the difference between the angle made by anvil's contact faces and spindle's axes and the half angle with error α .
Metric/Unified $\theta=60^\circ$
Whitworth $\theta=55^\circ$

Measurement example



Disc Micrometers
SERIES 323

- Measures "root tangent length" of spur gears and helical gears.
- Determination of the root tangent length: refer to "Quick Guide to Precision Measuring Instruments" on page 13-8.
- Equipped with Ratchet Stop for constant measuring force.



323-250-30

Optional Accessories

Code No.	Type	Description
264-020	—	USB Input Tool Series USB Keyboard Signal Conversion Type IT-020U
05CZA662	B	Connection cable (1 m)
05CZA663	B	Connection cable (2 m)
06AFM380B	B	USB Input Tool Direct (2 m)
02AZD730G	IP67	U-WAVE-T
02AZD880G	Buzzer	U-WAVE-T
02AZE200	—	U-WAVE-T mounting bracket
02AZD790B	B	Connection cable for U-WAVE-T (160 mm)
02AZE140B	B	Connection cable for U-WAVE-T For foot switch
264-622	IP67	U-WAVE-TM
264-623	Buzzer	U-WAVE-TM
264-626	IP67	U-WAVE-TMB
264-627	Buzzer	U-WAVE-TMB
02AZF310	IP67	Connecting unit for U-WAVE-TM/TMB

SPECIFICATIONS

Metric							
Code No.	Range (mm)	Resolution (mm)	Maximum permissible error J_{MPE} (μ m)	Flatness (μ m)	Parallelism (μ m)	Anvil dia. (mm)	Measurable module
With SPC data output							
323-250-30	0 - 25	0.001	±4	1	4	ø20	0.5 - 6
323-251-30	25 - 50						
323-252-30	50 - 75		±6				
323-253-30	75 - 100						

Inch / Metric							
Code No.	Range (in)	Resolution	Maximum permissible error J_{MPE} (in)	Flatness (in)	Parallelism (in)	Anvil dia. (in)	Measurable module
With SPC data output							
323-350-30	0 - 1	0.00005 in/ 0.001 mm	±0.0002	0.00004	0.0002	ø0.787	0.5 - 6
323-351-30	1 - 2						
323-352-30	2 - 3		±0.0003				
323-353-30	3 - 4						

- Power source: SR44 battery (1 pc.), **938882** included as standard (for operational checks)
 - Battery life: Approx. 2.4 years under normal use
 - Position detection method: Electromagnetic rotary sensor
 - Standard accessories: Setting standard, 1 pc. (except for measuring range 0 to 25 mm (0 to 1 in) models), Spanner (**301336**), 1 pc.
- Note 1: Root tangent length measurement is not available for some types of gears.
Note 2: For functional details, refer to page 02-7.
Optional connection cable is available only for water-proof type (Digimatic model).

DIMENSIONS

Digimatic models up to 75 mm measuring range

Unit: mm

Digimatic models up to 100 mm measuring range

Range (mm)	L	a	b	c	e	f	t
Digimatic (LCD)							
0 - 25	0	9.2	25	4.5	20	8	0.7
25 - 50	25	11	31	5.4			
50 - 75	50	12.2	50	5.5			
75 - 100	75	14	60				

Micrometer

Disc Micrometers SERIES 223, 123

- Can be used for making root tangent measurements on spur gears and helical gears.
- Determination of the root tangent length: refer to "Quick Guide to Precision Measuring Instruments" on page 13-8.
- Equipped with Ratchet Stop for constant measuring force.



123-101

SPECIFICATIONS

Metric							
Code No.	Range (mm)	Graduation (mm)	Maximum permissible error J_{MPE} (μm)	Flatness (μm)	Parallelism (μm)	Anvil dia. (mm)	Measurable module
Mechanical counter model							
223-101	0 - 25	0.01	± 4	1	4	$\varnothing 20$	0.5 - 6
223-102	25 - 50						
Analog							
123-101	0 - 25	0.01	± 4	1	4	$\varnothing 20$	0.5 - 6
123-113*							
123-102							
123-114*							
123-103	50 - 75						
123-115*							
123-104	75 - 100		± 6	1.6	7	$\varnothing 30$	0.7 - 11
123-116*							
123-105	100 - 125						
123-106	125 - 150						
123-107	150 - 175						
123-108	175 - 200						
123-109	200 - 225	± 8	1.6	8	$\varnothing 30$	0.7 - 11	
123-110	225 - 250						
123-111	250 - 275						
123-112	275 - 300	± 9		9			
Inch							
Code No.	Range (in)	Graduation (in)	Maximum permissible error J_{MPE} (in)	Flatness (in)	Parallelism (in)	Anvil dia. (in)	Measurable module
Mechanical counter model							
223-125	0 - 1	0.001	± 0.0002	0.00004	0.0002	$\varnothing 0.787$	0.5 - 6
Analog							
123-125	0 - 1	0.001	± 0.0002	0.00004	0.0002	$\varnothing 0.787$	0.5 - 6
123-126	1 - 2				0.0002		
123-127	2 - 3		± 0.0003		0.0003		
123-128	3 - 4				0.0003		

* The measuring discs have carbide tips.

• Standard accessories: Setting standard, 1 pc. (except for measuring range 0 to 25 mm (0 to 1 in) models), Spanner (301336), 1 pc.
Note: Root tangent length measurement is not available for some types of gears.

Disc Micrometers
SERIES 223, 123

DIMENSIONS

Analog models up to 50 mm measuring range

Unit: mm

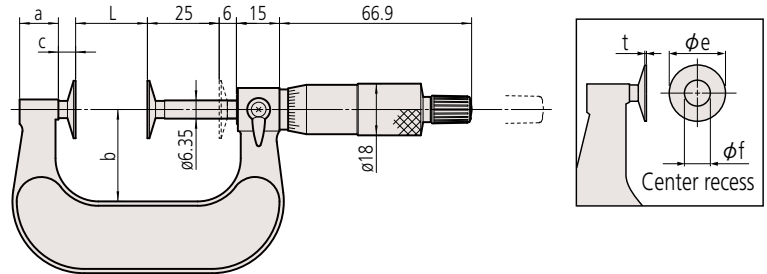

Analog models over 50 mm measuring range

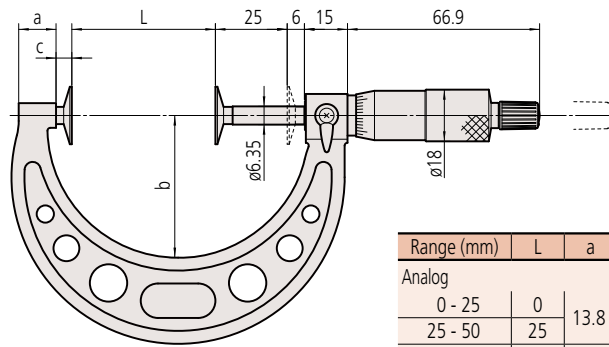

Range (mm)	L	a	b	c	e	f	t
Analog							
0 - 25	0	13.8	25	5.7	20	8 (9.8)	0.7 (0.7)
25 - 50	25		32				
50 - 75	50	12	49	5.5			
75 - 100	75	14	63				
100 - 125	100	12	79				
125 - 150	125	14.5	94				
150 - 175	150	15.2	106				
175 - 200	175	14.5	118				
200 - 225	200	13.5	130	6	30	12	1
225 - 250	225		143				
250 - 275	250	14.5	156				
275 - 300	275		169				

Note: Data in () applies to those with carbide-faced disks.

Micrometer

MeasurLink[®] ENABLED
Data Management Software by Mitutoyo

U-WAVE^{fit}



Dist- and
Water-
Protected
www.tuv.com
ID 0000640191

Gear Tooth Micrometers SERIES 324 — Interchangeable Ball Anvil/Spindle Tip Type

- This specialized micrometer series measures gear over-pin diameters. Attach optional ball probes to each measuring face before use.
- Determination of the over-pin diameter: refer to "Quick Guide to Precision Measuring Instruments" on page 13-8.
- Interchangeable ball anvils/spindle tips for various gear modules (0.5 to 5.25) are optional.



SPECIFICATIONS

Metric				Inch / Metric			
Code No.	Range (mm)	Resolution (mm)	Spindle feed error (μm)	Code No.	Range (in)	Resolution	Spindle feed error (in)
With SPC data output				With SPC data output			
324-251-30	0 - 25	0.001	3	324-351-30	0 - 1	0.00005 in/ 0.001 mm	0.00015
324-252-30	25 - 50			324-352-30	1 - 2		
324-253-30	50 - 75			324-353-30	2 - 3		
324-254-30	75 - 100			324-354-30	3 - 4		

- Power source: SR44 battery (1 pc.), **938882** included as standard (for operational checks)
 - Battery life: Approx. 2.4 years under normal use
 - Position detection method: Electromagnetic rotary sensor
 - Standard accessories: Setting standard, 1 pc. (except for measuring range 0 to 25 mm (0 to 1 in) models), Spanner (**301336**), 1 pc.
- Note: For functional details, refer to page 02-7.
Please note that origin setting of these models is by presetting. Optional connection cable is available only for water-proof type (Digimatic model).

DIMENSIONS

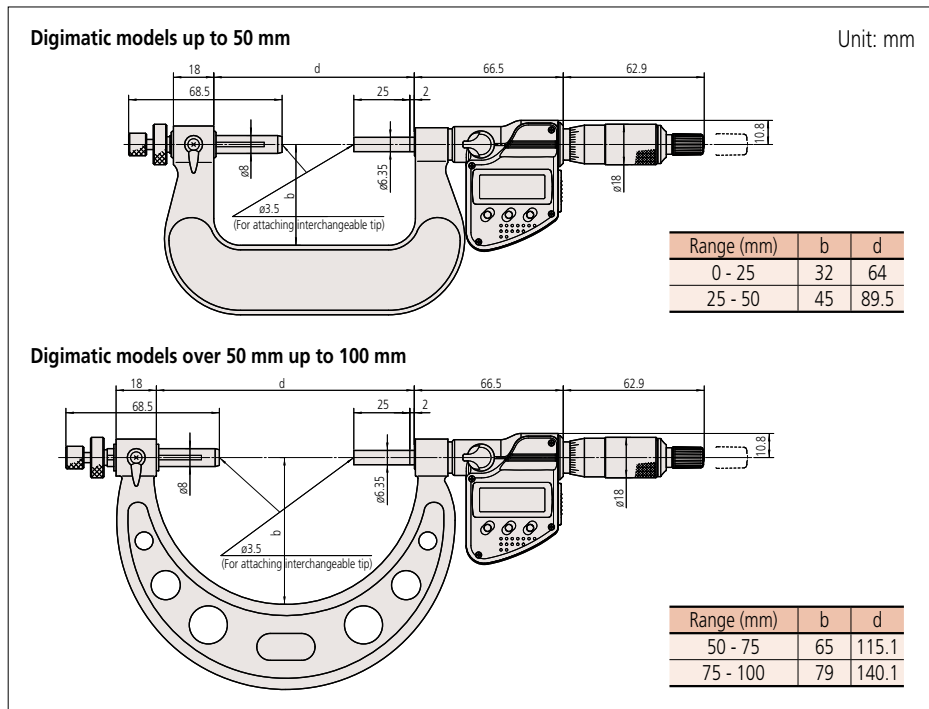

Measurement example

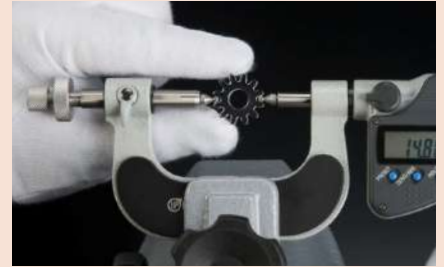

Optional Accessories

Code No.	Type	Description
264-020	—	USB Input Tool Series USB Keyboard Signal Conversion Type IT-020U
05CZA662	B	Connection cable (1 m)
05CZA663	B	Connection cable (2 m)
06AFM380B	B	USB Input Tool Direct (2 m)
02AZD730G	IP67	U-WAVE-T
02AZD880G	Buzzer	U-WAVE-T
02AZE200	—	U-WAVE-T mounting bracket
02AZD790B	B	Connection cable for U-WAVE-T (160 mm)
02AZE140B	B	Connection cable for U-WAVE-T For foot switch
264-622	IP67	U-WAVE-TM
264-623	Buzzer	U-WAVE-TM
264-626	IP67	U-WAVE-TMB
264-627	Buzzer	U-WAVE-TMB
02AZF310	IP67	Connecting unit for U-WAVE-TM/TMB

Micrometer

Disc Micrometers SERIES 369 — Non-rotating Spindle Type

- Can be used for making root tangent measurements on spur gears and helical gears.
- Determination of the root tangent length: refer to "Quick Guide to Precision Measuring Instruments" on page 13-8.
- Non-rotating spindle eliminates torque on workpiece.
- Measurable range of gear pitch: 0.5 to 6 module.
- Equipped with Ratchet Stop for constant measuring force.



Digimatic
369-250-30

SPECIFICATIONS

Metric							
Code No.	Range (mm)	Resolution (mm)	Anvil dia. (mm)	Maximum permissible error J_{MPE} (μm)	Flatness (μm)	Parallelism (μm)	Measuring force (N)
With SPC data output							
369-250-30	0 - 25	0.001	ø20	±4	1	4	3 - 8
369-251-30	25 - 50			±6		6	
369-252-30	50 - 75						
369-253-30	75 - 100						
Inch / Metric							
Code No.	Range (in)	Resolution	Anvil dia. (in)	Maximum permissible error J_{MPE} (in)	Flatness (in)	Parallelism (in)	Measuring force (N)
With SPC data output							
369-350-30	0 - 1	0.00005 in/ 0.001 mm	ø0.787	±0.0002	0.00004	0.0002	3 - 8
369-351-30	1 - 2			±0.0003		0.0003	
369-352-30	2 - 3						
369-353-30	3 - 4						

- Power source: SR44 battery (1 pc.), **938882** included as standard (for operational checks)
- Battery life: Approx. 2.4 years under normal use
- Position detection method: Electromagnetic rotary sensor
- Standard accessories: Setting standard, 1 pc. (except for measuring range 0 to 25 mm (0 to 1 in) models) Spanner (**301336**), 1 pc.

Note 1: For functional details, refer to page 02-7. Please note that these models are not water-proof.
Note 2: Root tangent length measurement is not available for some types of gears.

DIMENSIONS

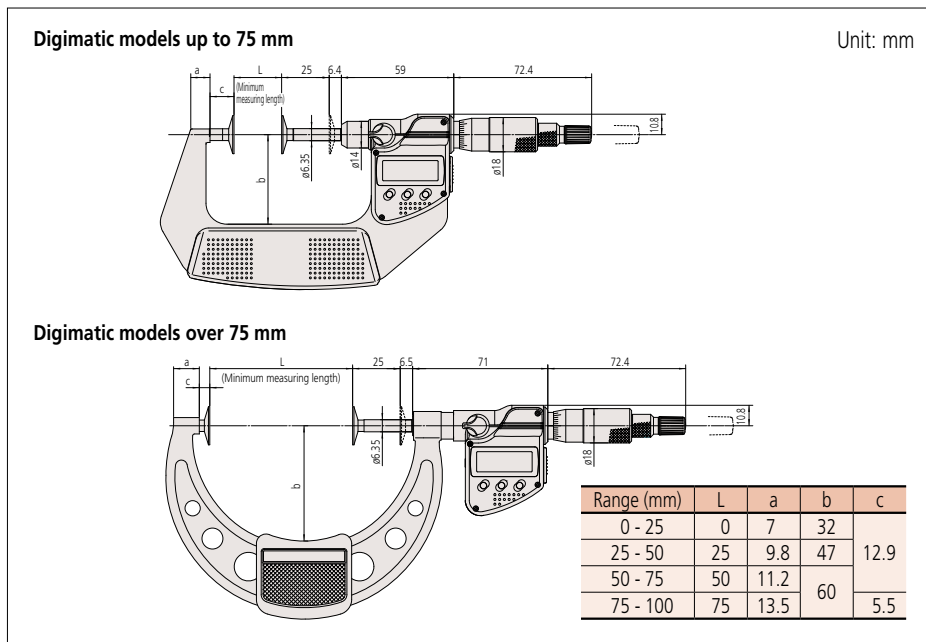

Measurement example



Optional Accessories

Code No.	Type	Description
264-020	—	USB Input Tool Series USB Keyboard Signal Conversion Type IT-020U
05CZA662	B	Connection cable (1 m)
05CZA663	B	Connection cable (2 m)
06AFM380B	B	USB Input Tool Direct (2 m)
02AZD730G	IP67	U-WAVE-T
02AZD880G	Buzzer	U-WAVE-T
02AZE200	—	U-WAVE-T mounting bracket
02AZD790B	B	Connection cable for U-WAVE-T (160 mm)
02AZE140B	B	Connection cable for U-WAVE-T For foot switch
264-622	IP67	U-WAVE-TM
264-623	Buzzer	U-WAVE-TM
264-626	IP67	U-WAVE-TMB
264-627	Buzzer	U-WAVE-TMB
02AZF310	IP67	Connecting unit for U-WAVE-TM/TMB

Disc Micrometers SERIES 369, 227 — Non-rotating Spindle Type

- Can be used for making root tangent measurements on spur gears and helical gears.
- Determination of the root tangent length: refer to "Quick Guide to Precision Measuring Instruments" on page 13-8.
- Non-rotating spindle eliminates torque on workpiece.
- Measurable range of gear pitch: 0.5 to 6 module (**series 227**: 0.4 to 3 module).
- Equipped with Ratchet Stop for constant measuring force.



Quickmike type
369-411-20

SPECIFICATIONS

Metric								
	Code No.	Range (mm)	Resolution (mm)	Anvil dia. (mm)	Maximum permissible error J_{MPE} (μm)	Flatness (μm)	Parallelism (μm)	Measuring force (N)
Quickmike type	369-411-20	0 - 30	0.001	$\varnothing 20$	± 4	1	4	3 - 8
	369-412-20	25 - 55						
Quickmike type adjustable measuring force	227-221-20	0 - 15		$\varnothing 14.3$			3	0.5 - 2.5
	227-223-20	0 - 10		2 - 10				

Inch / Metric								
	Code No.	Range (in)	Resolution	Anvil dia. (in)	Maximum permissible error J_{MPE} (in)	Flatness (in)	Parallelism (in)	Measuring force (N)
Quickmike type	369-421-20	0 - 1.2	0.00005 in/ 0.001 mm	$\varnothing 0.787$	± 0.0002	0.00004	0.0002	3 - 8
	369-422-20	1 - 2.2						

- Power source: SR44 battery (1 pc.), **938882** included as standard (for operational checks)
- Battery life: Approx. 5 years under normal use
- Position detection method: Electrostatic capacity absolute sensor
- Standard accessories: Setting standard, 1 pc. (except for measuring range 0 to 10 mm/0 to 15 mm/0 to 30 mm (0 to 1/0 to 1.2 in) models), Screwdriver (**210183**), 1 pc.

Note: Root tangent length measurement is not available for some types of gears.

DIMENSIONS

Quickmike type

Unit: mm

Range (mm)	L	a	b	c
0 - 30	0	8.5	36	13.5
25 - 55	25	10.3	47	

Quickmike adjustable measuring force type

Range (mm)	L	a	b	c
0 - 15	0	6.2	25	5.2
0 - 10				

Micrometer

Disc Micrometers

SERIES 169 — Non-rotating Spindle Type

- Can be used for making root tangent measurements on spur gears and helical gears.
- Determination of the root tangent length: refer to "Quick Guide to Precision Measuring Instruments" on page 13-8.
- Non-rotating spindle eliminates torque on workpiece.
- Measurable range of gear pitch: 0.5 to 6 module.
- Equipped with Ratchet Stop for constant measuring force.



169-201-10

SPECIFICATIONS

Metric								
	Code No.	Range (mm)	Graduation (mm)	Anvil dia. (mm)	Maximum permissible error J_{MPE} (μ m)	Flatness (μ m)	Parallelism (μ m)	Measuring force (N)
Analog	169-201-10	0 - 25	0.01	\varnothing 20	\pm 4	1	4	3 - 8
	169-202-10	25 - 50						
	169-205-10	50 - 75			\pm 6		6	
	169-207-10	75 - 100						

Inch								
	Code No.	Range (in)	Graduation (in)	Anvil dia. (in)	Maximum permissible error J_{MPE} (in)	Flatness (in)	Parallelism (in)	Measuring force (N)
Analog	169-203-10	0 - 1	0.001	\varnothing 0.787	\pm 0.0002	0.00004	0.0002	3 - 8
	169-204-10	1 - 2						
	169-206-10	2 - 3			\pm 0.0003		0.0003	
	169-208-10	3 - 4						

• Standard accessories: Setting standard, 1 pc. (except for measuring range 0 to 25 mm (0 to 1 in) models)
Spanner (301336), 1 pc.

Note: Root tangent length measurement is not available for some types of gears.

DIMENSIONS

Unit: mm

Analog models up to 50 mm

Analog models over 50 mm

Range (mm)	L	a	b	c	e	f	t
0 - 25	0	13.8	25	5.7	20	8	0.7
25 - 50	25		32				
50 - 75	50	12	49				
75 - 100	75	14	63				

Paper Thickness Micrometers SERIES 169 — Non-rotating Spindle Type

Measurement example



- For paper thickness measurement.
- Non-rotating spindle eliminates torque on workpiece.
- Anvil diameter: $\varnothing 14.3$ mm (without recess)
- Equipped with Ratchet Stop for constant measuring force. (8.02 \pm 0.8 N)



169-101-10

SPECIFICATIONS

Metric					
Code No.	Range (mm)	Graduation (mm)	Maximum permissible error J_{MPE} (μ m)	Flatness (μ m)	Parallelism (μ m)
169-101-10	0 - 25	0.01	± 4	1	3
Inch					
Code No.	Range (in)	Graduation (in)	Maximum permissible error J_{MPE} (in)	Flatness (in)	Parallelism (in)
169-103-10	0 - 1	0.001	± 0.0002	0.00004	0.00015

- Standard Accessories: Spanner (301336), 1 pc.

DIMENSIONS

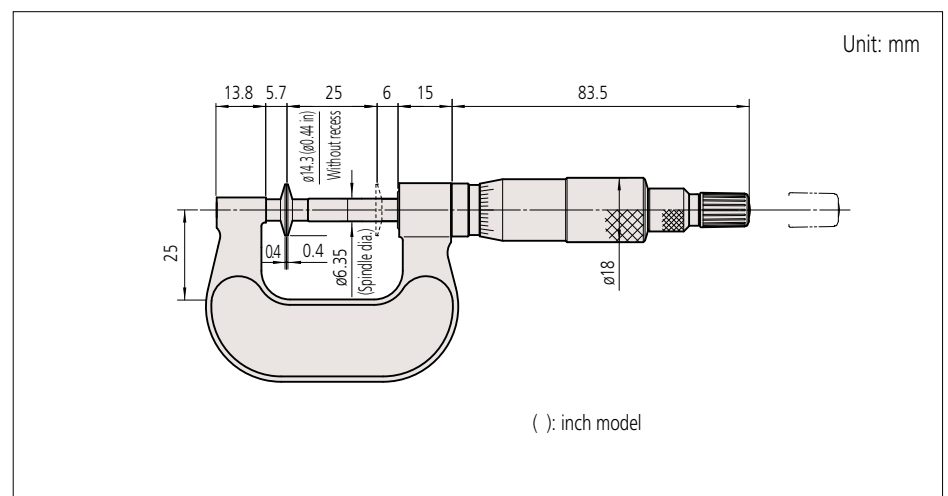

Sheet Metal Micrometers SERIES 118

- The U-shaped micrometer is ideal for measuring the thickness of sheet metal at a considerable distance from the edge.
- Measuring faces: Carbide tipped
- Profile of measuring faces: Flat-Flat, Spherical-Flat and Spherical-Spherical.
- Equipped with Ratchet Stop for constant measuring force.



SPECIFICATIONS

Metric							
Code No.	Range (mm)	Graduation (mm)	Maximum permissible error J_{MPE} (μm)	Flatness (μm)	Parallelism (μm)	Throat depth (mm)	Measuring surfaces
Analog							
118-101	0 - 25	0.01	±4	0.6	3	100	F-F
118-102						150	S-F
118-114						150	S-S
118-103						300*	F-F
118-110						150	S-S
118-126	25 - 50		±4	0.6			

Inch							
Code No.	Range (in)	Graduation (in)	Maximum permissible error J_{MPE} (in)	Flatness (in)	Parallelism (in)	Throat depth (in)	Measuring surfaces
Analog							
118-129	0 - 1	0.0001	±0.0002	0.000024	0.00012	6	F-F
118-116							S-F
118-120							S-S
118-107						12*	F-F
118-112	1 - 2	0.001	±0.00025	0.00004		6	F-F
			±0.0002	0.000024			

- Standard accessories: Setting standard, 1 pc. (except for measuring range 0 to 25 mm (0 to 1 in) models)
 - Spanner (200877), 1 pc. (for 118-1XX)
 - Spanner (200154), 1 pc. (for 118-103/107)
 - * Models with a 300 mm (12 in) throat are equipped with a stand for convenience of measurement in the horizontal orientation as standard.
- Note: In spherical-flat anvil type micrometers, the measuring face on the anvil side is spherical.

DIMENSIONS

Analog models

Unit: mm

Code No.	L	a	b	c
118-101	0	34	110	2.5
118-102		43	160	
118-114		43	160	
118-118		43	160	
118-110	25	41	165	

Micrometer

Sheet Metal Micrometer SERIES 119

- Large diameter dial model enables easy and quick measurement of sheet metal thickness.
- Adjustable anvil.
- Measuring faces: Carbide tipped
- Equipped with Ratchet Stop for constant measuring force.



119-202

SPECIFICATIONS

Metric

Code No.	Range (mm)	Graduation (mm)	Maximum permissible error J_{MPE} (μm)	Throat depth (mm)
119-202	0 - 25	0.01	± 4	50

• Standard Accessories: Spanner (200168), 1 pc.

DIMENSIONS

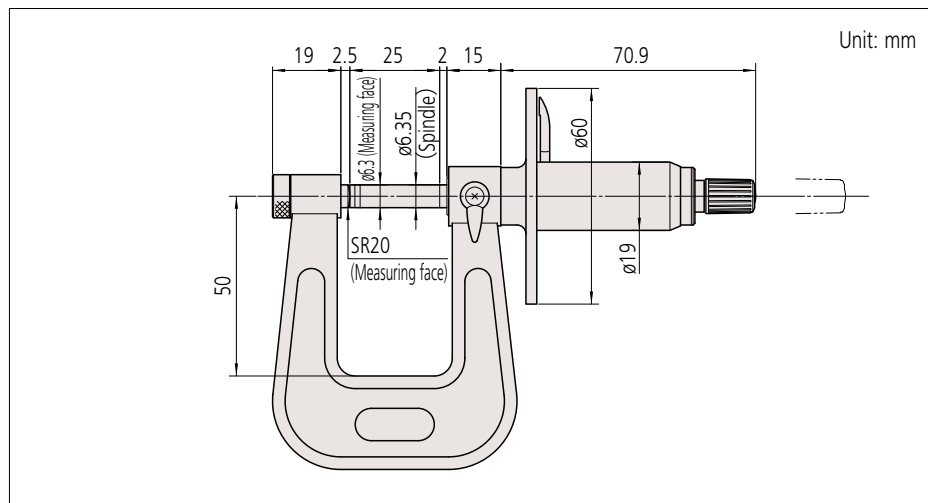

Measurement example





Dust- and Water-Protected
www.tuv.com
ID: 000004091

Applicable models: series 395

Measurement example

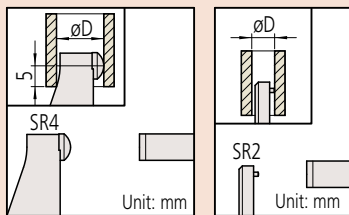

Other than 115-101

115-101

Optional Accessories

Code No.	Type	Description
264-020	—	USB Input Tool Series USB Keyboard Signal Conversion Type IT-020U
05CZA662	B	Connection cable for series 395 (1 m)
05CZA663	B	Connection cable for series 395 (2 m)
06AFM380B	B	USB Input Tool Direct (2 m)
02AZD730G	IP67	U-WAVE-T
02AZD880G	Buzzer	U-WAVE-T
02AZE200	—	U-WAVE-T mounting bracket
02AZD790B	B	Connection cable for U-WAVE-T (160 mm)
02AZE140B	B	Connection cable for U-WAVE-T For foot switch
264-622	IP67	U-WAVE-TM
264-623	Buzzer	U-WAVE-TM
264-626	IP67	U-WAVE-TMB
264-627	Buzzer	U-WAVE-TMB
02AZF310	IP67	Connecting unit for U-WAVE-TM/TMB

Tube Micrometers SERIES 395, 115, 295

- The spherical anvil-type micrometer is convenient for measuring cylindrical workpieces. The spherical anvil comes into contact with a workpiece at a point instead of a surface area, thus increasing measurement accuracy.

- IP65 water/dust protection (series 395).
- Equipped with Ratchet Stop for constant measuring force.



395-251-30

SPECIFICATIONS

Metric					
Code No.	Range (mm)	Resolution (mm)	Maximum permissible error J_{MPE} (μ m)	ϕD (mm)	Flatness (μ m)
Digimatic					
395-251-30	0 - 25	0.001	± 2	$\phi 15$	0.3
395-252-30	25 - 50			$\phi 19$	
395-253-30	50 - 75			$\phi 20$	
395-254-30	75 - 100			± 3	

Inch/Metric					
Code No.	Range (in)	Resolution	Maximum permissible error J_{MPE} (in)	ϕD (in)	Flatness (in)
Digimatic					
395-351-30	0 - 1	0.00005 in/ 0.001 mm	± 0.0001	$\phi 0.59$	0.000012
395-352-30	1 - 2			$\phi 0.75$	
395-353-30	2 - 3			$\phi 0.75$	
395-354-30	3 - 4			± 0.00015	

- Power source: SR44 battery (1 pc.), 938882 included as standard (for operational checks)
- Battery life: Approx. 2.4 years under normal use
- Position detection method: Electromagnetic rotary sensor
- Standard accessories: Setting standard, 1 pc. (except for measuring range 0 to 25 mm (0 to 1 in) models), Spanner (301336), 1 pc.

Note: For functional details, refer to page 02-7.
Optional connection cable is available only for water-proof type (Digimatic model).



115-115

SPECIFICATIONS

Metric					
Code No.	Range (mm)	Graduation (mm)	Maximum permissible error J_{MPE} (μ m)	ϕD (mm)	Flatness (μ m)
Analog					
115-101	0 - 15	0.01	± 3	$\phi 5.5$	0.6
115-115	0 - 25			$\phi 10$	
115-116	25 - 50			$\phi 11$	
115-117	50 - 75			$\phi 17$	
115-118	75 - 100			± 4	
Mechanical counter model					
295-115	0 - 25	0.01	± 3	$\phi 10$	0.6

Inch					
Code No.	Range (in)	Graduation (in)	Maximum permissible error J_{MPE} (in)	ϕD (in)	Flatness (in)
Analog					
115-153	0 - 1	0.0001	± 0.00015	$\phi 0.40$	0.000024
Mechanical counter model					
295-153	0 - 1	0.0001	± 0.00015	$\phi 0.40$	0.000024

- Standard accessories: Setting standard, 1 pc. (except for measuring range 0 to 15 mm / 0 to 25 mm (0 to 1 in) models)
Spanner (200168), 1 pc. (for 115-101), Spanner (301336), 1 pc. (for models other than 115-101)

DIMENSIONS

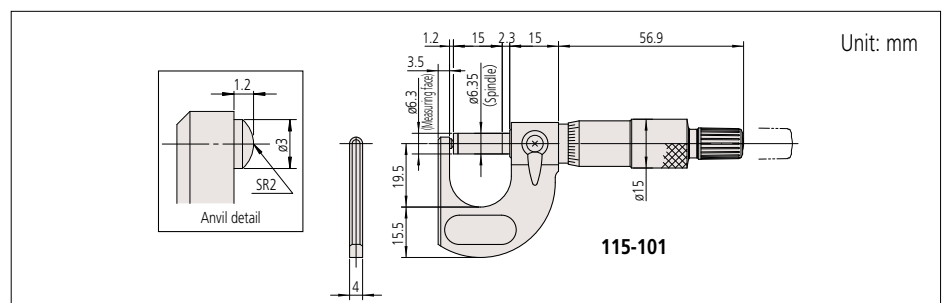

115-101

Micrometer



Applicable models: **series 395**

Tube Micrometers SERIES 395, 115, 295 — Spherical Anvil and Spindle Type

- Designed to measure workpieces with concave-concave surfaces. The spherical anvil and spindle respectively come into contact with the workpiece at a point, thus increasing measurement accuracy.
- IP65 water/dust protection (**series 395**).
- Equipped with Ratchet Stop for constant measuring force.



395-271-30

SPECIFICATIONS

Metric					Inch/Metric				
Code No.	Range (mm)	Resolution (mm)	Maximum permissible error J_{MPE} (μ m)	ϕ D (mm)	Code No.	Range (in)	Resolution	Maximum permissible error J_{MPE} (in)	ϕ D (in)
Digimatic					Digimatic				
395-271-30	0 - 25	0.001	± 2	$\phi 15$	395-371-30	0 - 1	0.00005 in/ 0.001 mm	± 0.0001	$\phi 0.59$
395-272-30	25 - 50				395-372-30	1 - 2			
395-273-30	50 - 75			395-373-30	2 - 3	$\phi 0.75$			
395-274-30	75 - 100			± 3	$\phi 20$	395-374-30			3 - 4

- Power source: SR44 battery (1 pc.), **938882** included as standard (for operational checks)
 - Battery life: Approx. 2.4 years under normal use
 - Position detection method: Electromagnetic rotary sensor
 - Standard accessories: Setting standard, 1 pc. (except for measuring range 0 to 25 mm (0 to 1 in) models), Spanner (**301336**), 1 pc.
- Note: For functional details, refer to page 02-7.
Optional connection cable is available only for water-proof type (Digimatic model).



115-215

SPECIFICATIONS

Metric					Inch				
Code No.	Range (mm)	Graduation (mm)	Maximum permissible error J_{MPE} (μ m)	ϕ D (mm)	Code No.	Range (in)	Graduation (in)	Maximum permissible error J_{MPE} (in)	ϕ D (in)
Analog					Analog				
115-201	0 - 15	0.01	± 3	$\phi 5.5$	115-253	0 - 1	0.0001	± 0.00015	$\phi 0.40$
115-215	0 - 25			$\phi 10$	115-242	1 - 2	0.001		$\phi 0.44$
115-216	25 - 50			$\phi 11$	115-243	2 - 3			$\phi 0.67$
115-217	50 - 75			$\phi 17$	Mechanical counter model				
115-218	75 - 100			$\phi 18$	295-253	0 - 1	0.0001	± 0.00015	$\phi 0.40$
Mechanical counter model									
295-215	0 - 25	0.01	± 3	$\phi 10$					

- Standard accessories: Setting standard, 1 pc. (except for measuring range 0 to 15 mm/0 to 25 mm (0 to 1 in) models)
- Spanner (**200168**), 1 pc. (for **115-201**), Spanner (**301336**), 1 pc. (for models other than **115-201**)

DIMENSIONS

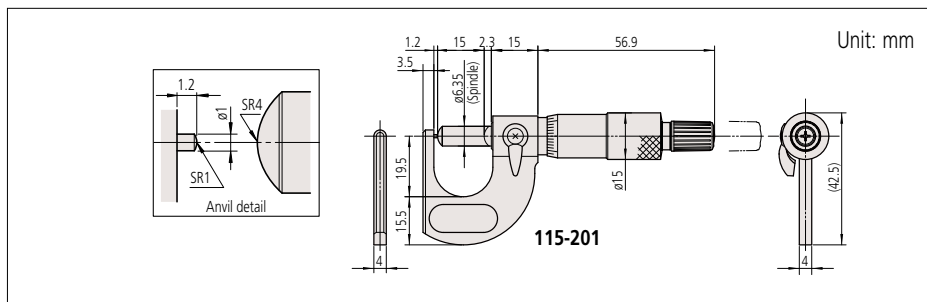

Measurement example

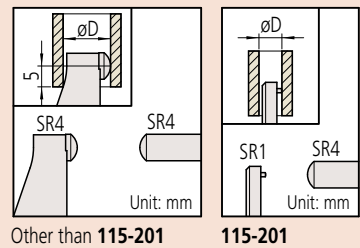

Other than **115-201** **115-201**

Optional Accessories

Code No.	Type	Description
264-020	—	USB Input Tool Series USB Keyboard Signal Conversion Type IT-020U
05CZA662	B	Connection cable for series 395 (1 m)
05CZA663	B	Connection cable for series 395 (2 m)
06AFM380B	B	USB Input Tool Direct (2 m)
02AZD730G	IP67	U-WAVE-T
02AZD880G	Buzzer	U-WAVE-T
02AZE200	—	U-WAVE-T mounting bracket
02AZD790B	B	Connection cable for U-WAVE-T (160 mm)
02AZE140B	B	Connection cable for U-WAVE-T For foot switch
264-622	IP67	U-WAVE-TM
264-623	Buzzer	U-WAVE-TM
264-626	IP67	U-WAVE-TMB
264-627	Buzzer	U-WAVE-TMB
02AZF310	IP67	Connecting unit for U-WAVE-TM/TMB



Dust- and Water- Protected
www.tuv.com
ID 000004091

Applicable models: series 395

Measurement example



Type A (pin)

Type B (spherical)



Type C (cylindrical)

Type D (cylindrical)

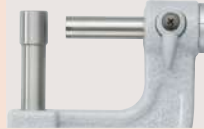

Optional Accessories

Code No.	Type	Description
264-020	—	USB Input Tool Series USB Keyboard Signal Conversion Type IT-020U
05CZA662	B	Connection cable for series 395 (1 m)
05CZA663	B	Connection cable for series 395 (2 m)
06AFM380B	B	USB Input Tool Direct (2 m)
02AZD730G	IP67	U-WAVE-T
02AZD880G	Buzzer	U-WAVE-T
02AZE200	—	U-WAVE-T mounting bracket
02AZD790B	B	Connection cable for U-WAVE-T (160 mm)
02AZE140B	B	Connection cable for U-WAVE-T For foot switch
264-622	IP67	U-WAVE-TM
264-623	Buzzer	U-WAVE-TM
264-626	IP67	U-WAVE-TMB
264-627	Buzzer	U-WAVE-TMB
02AZF310	IP67	Connecting unit for U-WAVE-TM/TMB

Anvil shape

Anvil	øD	L
Type A	ø2.0	4
Type B	ø3.6	4
Type C	ø4.8	12
Type D	ø8.2	22

Tube Micrometers
SERIES 395, 115, 295 — Spherical and Cylindrical Anvil Type

- Designed to measure the wall thickness of various tubing.
- Spindle face: Carbide tipped
- IP65 water/dust protection (series 395).
- Equipped with Ratchet Stop for constant measuring force.



395-261-30

SPECIFICATIONS

Metric				
Code No.	Range (mm)	Resolution (mm)	Maximum permissible error J_{MPE} (µm)	Remarks
Digimatic				
395-261-30	0 - 25	0.001	±3	Type A
395-262-30				Type B
395-263-30				Type C
395-264-30				Type D

Inch / Metric				
Code No.	Range (in)	Resolution	Maximum permissible error J_{MPE} (in)	Remarks
Digimatic				
395-362-30	0 - 1	0.00005 in/ 0.001 mm	±0.00015	Type B
395-363-30				Type C
395-364-30				Type D

- Power source: SR44 battery (1 pc.), 938882 included as standard (for operational checks)
 - Battery life: Approx. 2.4 years under normal use
 - Position detection method: Electromagnetic rotary sensor
 - Standard accessories: Spanner (301336), 1 pc.
- Note: For functional details, refer to page 02-7.
Optional connection cable is available only for water-proof type (Digimatic model).

DIMENSIONS

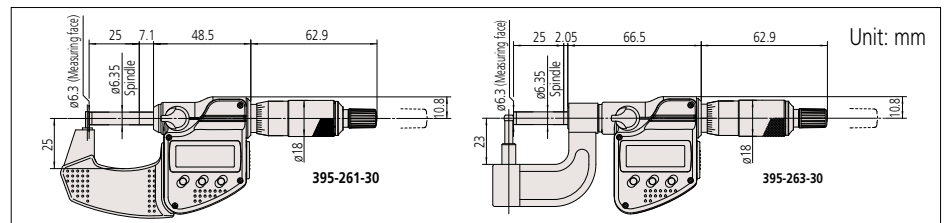

SPECIFICATIONS

Metric				
Code No.	Range (mm)	Graduation (mm)	Maximum permissible error J_{MPE} (µm)	Remarks
Analog				
115-302	0 - 25	0.01	±3	Type A
115-308				Type B
115-303				Type A
115-315	25 - 50	0.01	±3	Type B
115-316				Type C
115-311	0 - 25	0.01	±3	Type C
115-312				Type D

Inch				
Code No.	Range (in)	Graduation (in)	Maximum permissible error J_{MPE} (in)	Remarks
Analog				
115-305	0 - 1	0.001	±0.00015	Type A
115-313				Type C
115-314				Type D

- Standard accessories: Setting standard, 1 pc. (except for measuring range 0 to 25 mm (0 to 1 in) models)
- Spanner (301336), 1 pc.

DIMENSIONS

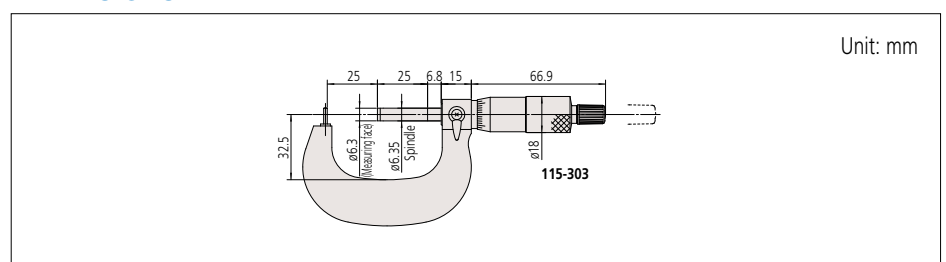

Micrometer

MeasurLink[®] ENABLED
Data Management Software by Mitutoyo

U-WAVE^{fit}

IP65

TUV Rheinland
CERTIFIED
Dust- and
Water-
Protected
www.tuv.com
ID 0000640191

Spline Micrometers SERIES 331

- The anvil and spindle have a small diameter for measuring splined shafts, slots and keyways.
- Measuring faces: Carbide tipped
- Equipped with Ratchet Stop for constant measuring force.
- IP65 water/dust protection.



SPECIFICATIONS

Metric						
Code No.	Range (mm)	Resolution (mm)	Maximum permissible error J_{MPE} (μ m)	Flatness (μ m)	Parallelism (μ m)	Measuring face
Digimatic						
331-251-30	0 - 25	0.001	± 2	0.3	2	Type A
331-252-30	25 - 50					
331-253-30	50 - 75					
331-254-30*	75 - 100		± 3		3	
331-261-30	0 - 25		± 2			2
331-262-30	25 - 50					
331-263-30	50 - 75	± 3	3			
331-264-30*	75 - 100					

Inch / Metric						
Code No.	Range (in)	Resolution	Maximum permissible error J_{MPE} (in)	Flatness (in)	Parallelism (in)	Measuring face
Digimatic						
331-351-30	0 - 1	0.00005 in/ 0.001 mm	± 0.0001	0.000012	0.00008	Type A
331-352-30	1 - 2					
331-353-30	2 - 3					
331-354-30	3 - 4		± 0.00015		0.00008	
331-361-30	0 - 1		± 0.0001			2
331-362-30	1 - 2					
331-363-30	2 - 3	± 0.00015	3			
331-364-30	3 - 4					

- Power source: SR44 battery (1 pc.), **938882** included as standard (for operational checks)
 - Battery life: Approx. 2.4 years under normal use
 - Position detection method: Electromagnetic rotary sensor
 - Standard accessories: Setting standard, 1 pc. (except for measuring range 0 to 25 mm (0 to 1 in) models), Spanner (**301336**), 1 pc.
 - * Made to order.
- Note: For functional details, refer to page 02-7.
Optional connection cable is available only for water-proof type (Digimatic model).

DIMENSIONS

Digimatic models
Models up to 75 mm measuring range

Digimatic models
Models over 75 mm measuring range

Unit: mm

Code No.	L	a	b	c
331-251-30	0	7.3	32.5	17.5
331-261-30	25	10.1	47	
331-252-30	50	11.5	60	20.3
331-253-30	75	16.7	76	

Measurement example

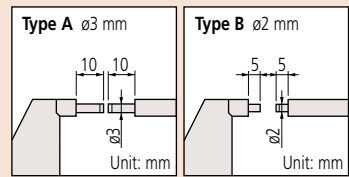

Optional Accessories

Code No.	Type	Description
264-020	—	USB Input Tool Series USB Keyboard Signal Conversion Type IT-020U
05CZA662	B	Connection cable (1 m)
05CZA663	B	Connection cable (2 m)
06AFM380B	B	USB Input Tool Direct (2 m)
02AZD730G	IP67	U-WAVE-T
02AZD880G	Buzzer	U-WAVE-T
02AZE200	—	U-WAVE-T mounting bracket
02AZD790B	B	Connection cable for U-WAVE-T (160 mm)
02AZE140B	B	Connection cable for U-WAVE-T For foot switch
264-622	IP67	U-WAVE-TM
264-623	Buzzer	U-WAVE-TM
264-626	IP67	U-WAVE-TMB
264-627	Buzzer	U-WAVE-TMB
02AZF310	IP67	Connecting unit for U-WAVE-TM/TMB

Spline Micrometers SERIES 111, 131

- The anvil and spindle have a small diameter for measuring splined shafts, slots and keyways.
- Measuring faces: Carbide tipped
- Equipped with Ratchet Stop for constant measuring force.



111-115

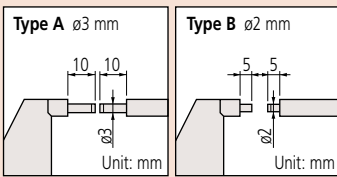

SPECIFICATIONS

Metric						
Code No.	Range (mm)	Graduation (mm)	Maximum permissible error J_{MPE} (μ m)	Flatness (μ m)	Parallelism (μ m)	Measuring face
Analog						
111-215	0 - 25	0.01	± 3	0.3	2	Type B
111-115	0 - 25					
111-116	25 - 50					
111-117	50 - 75					
111-118	75 - 100		± 4		3	Type A
111-119	100 - 125					
111-120	125 - 150					
111-121	150 - 175					
111-122	175 - 200		± 5		4	
111-123	200 - 225					
111-124	225 - 250					
111-125	250 - 275					
111-126	270 - 300	± 6	5			
Mechanical counter model						
131-115	0 - 25	0.01	± 3	0.3	2	Type A

Inch						
Code No.	Range (in)	Graduation (in)	Maximum permissible error J_{MPE} (in)	Flatness (in)	Parallelism (in)	Measuring face
Analog						
111-166	0 - 1	0.0001	± 0.00015	0.000012	0.00008	Type A
131-166			± 0.00015			

• Standard accessories: Setting standard, 1 pc. (except for measuring range 0 to 25 mm (0 to 1 in) models), Spanner (301336), 1 pc.

DIMENSIONS

Analog models

Models up to 300 mm measuring range

Unit: mm

Code No.	L	a	b	c
111-215	0	10	38	17.5
111-115				
111-116	25	12	49	
111-117	50	14	60	20.3
111-118	75	16.7	79	
111-119	100	18.8	94	20.7
111-120	125	19.1	106	21.1
111-121	150	18.2	118	21.3
111-122	175	16.8	130	21.7
111-123	200		143	20.5
111-124	225	18	156	21.5
111-125	250		169	
111-126	275		181	

Micrometer

MeasurLink[®] ENABLED
Data Management Software by Mitutoyo

U-WAVE^{fit}



Dust- and Water- Protected
www.tuv.com
ID 000040191

Point Micrometers SERIES 342

- Pointed spindle and anvil for measuring the web thickness of drills, small grooves, keyways, and other hard-to-reach dimensions.
- The measuring points (carbide tipped) have approximately 0.3 mm radius.
- Measuring faces: Carbide tipped
- IP65 water/dust protection
- Equipped with Ratchet Stop for constant measuring force.



342-251-30

SPECIFICATIONS

Metric					Inch / Metric				
Code No.	Range (mm)	Resolution (mm)	Maximum permissible error J_{MPE} (μ m)	Point	Code No.	Range (in)	Resolution	Maximum permissible error J_{MPE} (in)	Point
Digimatic (With carbide tip)					Digimatic (With carbide tip)				
342-251-30	0 - 25	0.001	±2	15°	342-351-30	0 - 1	0.00005 in/ 0.001 mm	±0.0001	15°
342-252-30	25 - 50				342-352-30	1 - 2			
342-253-30	50 - 75				342-353-30	2 - 3			
342-254-30	75 - 100		±3	342-354-30	3 - 4				
342-261-30	0 - 25		±2	30°	342-361-30	0 - 1		±0.0001	30°
342-262-30	25 - 50				342-362-30	1 - 2			
342-263-30	50 - 75	342-363-30			2 - 3				
342-264-30	75 - 100	±3	342-364-30	3 - 4	±0.00015				

- Power source: SR44 battery (1 pc., **938882** included as standard (for operational checks)
 - Battery life: Approx. 2.4 years under normal use
 - Position detection method: Electromagnetic rotary sensor
 - Standard accessories: Setting standard, 1 pc. (except for measuring range 0 to 25 mm (0 to 1 in) models), Spanner (**301336**), 1 pc.
- Note: For functional details, refer to page 02-7.
Optional connection cable is available only for water-proof type (Digimatic model).

DIMENSIONS

Unit: mm

Digimatic models up to 75 mm measuring range

Digimatic models over 75 mm measuring range

Code No.	L	a	b	c	Frame thickness*
342-251-30	0	7.3	32.5		(11.2)
342-261-30					
342-252-30	25	10.1	47	12.5	(12.8)
342-262-30					
342-253-30	50	11.5	60		
342-263-30					
342-254-30	75	16.7	76	15.3	(20.8)
342-264-30					

* Digimatic type: thickness over heat shield

Measurement example

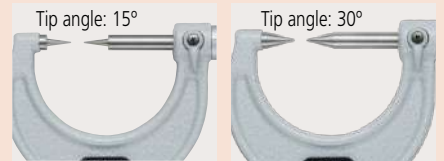

Optional Accessories

Code No.	Type	Description
264-020	—	USB Input Tool Series USB Keyboard Signal Conversion Type IT-020U
05CZA662	B	Connection cable (1 m)
05CZA663	B	Connection cable (2 m)
06AFM380B	B	USB Input Tool Direct (2 m)
02AZD730G	IP67	U-WAVE-T
02AZD880G	Buzzer	U-WAVE-T
02AZE200	—	U-WAVE-T mounting bracket
02AZD790B	B	Connection cable for U-WAVE-T (160 mm)
02AZE140B	B	Connection cable for U-WAVE-T For foot switch
264-622	IP67	U-WAVE-TM
264-623	Buzzer	U-WAVE-TM
264-626	IP67	U-WAVE-TMB
264-627	Buzzer	U-WAVE-TMB
02AZF310	IP67	Connecting unit for U-WAVE-TM/TMB

Point Micrometers SERIES 112, 142

- Pointed spindle and anvil for measuring the web thickness of drills, small grooves, keyways, and other hard-to-reach dimensions.
- The measuring points have approximately 0.3 mm radius.
- Carbide measuring tips are also available.
- Equipped with Ratchet Stop for constant measuring force.



112-201

SPECIFICATIONS

Metric					
Code No.	Range (mm)	Graduation (mm)	Maximum permissible error J_{MPE} (μ m)	Point	
Analog					
112-153	0 - 25	0.01	± 3	15°	
112-154	25 - 50				
112-155	50 - 75		± 4	30°	
112-156	75 - 100				
112-201	0 - 25		0.01	± 3	30°
112-202	25 - 50				
112-203	50 - 75	± 4		15°	
112-204	75 - 100				
Analog (With carbide tip)					
112-165	0 - 25	0.01	± 3	15°	
112-166	25 - 50				
112-167	50 - 75		± 4	30°	
112-168	75 - 100				
112-213	0 - 25		0.01	± 3	30°
112-214	25 - 50				
112-215	50 - 75	± 4		15°	
112-216	75 - 100				
Mechanical counter model					
142-153	0 - 25	0.01	± 3	15°	
142-201				30°	

Inch				
Code No.	Range (in)	Graduation (in)	Maximum permissible error J_{MPE} (in)	Point
Analog				
112-177	0 - 1	0.001	± 0.00015	15°
112-178	1 - 2			30°
112-225	0 - 1		± 0.00015	
112-226	1 - 2			
Analog (With carbide tip)				
112-189	0 - 1	0.001	± 0.00015	15°
112-190	1 - 2			30°
112-191	2 - 3		± 0.00015	
112-237	0 - 1			
112-238	1 - 2	0.001	± 0.00015	30°
112-238	1 - 2			
Mechanical counter model				
142-177	0 - 1	0.001	± 0.00015	15°
142-225				30°

• Standard accessories: Setting standard, 1 pc. (except for measuring range 0 to 25 mm (0 to 1 in) models), Spanner (301336), 1 pc.

DIMENSIONS

Analog models measuring range

Unit: mm

Code No.	L	a	b	c	Frame thickness
112-153	0	10	38		(9)
112-154	25	12	49	12.5	(10)
112-155	50	14	60		(11)
112-156	75	16.7	79	15.3	(13)

V-Anvil Micrometers SERIES 314 — 3 Flutes

- Measures the outside diameter of cutting tools (such as taps, reamers, end mills) with an odd number of flutes.
- Measures pitch diameter: refer to "Quick Guide to Precision Measuring Instruments" on page 13-8.
- Measuring faces: Carbide tipped
- Equipped with Ratchet Stop for constant measuring force.



314-251-30

SPECIFICATIONS

Metric For 3-flute cutting tools						Inch / Metric For 3-flute cutting tools					
Code No.	Range (mm)	Resolution (mm)	Maximum permissible error J_{MPE} (μ m)	Anvil	Remarks	Code No.	Range (in)	Resolution	Maximum permissible error J_{MPE} (in)	Anvil	Remarks
Digimatic						Digimatic					
314-251-30	1 - 15	0.001	± 4	60°	w/groove	314-351-30	0.05 - 0.6	0.00005 in/ 0.001 mm	± 0.0002	60°	w/groove
314-252-30	10 - 25				314-352-30	0.4 - 1					
314-253-30	25 - 40				314-353-30	1 - 1.6					
314-261-30	1 - 15				314-361-30	0.05 - 0.6					
314-262-30	10 - 25				314-362-30	0.4 - 1					

- Flatness: 0.3 μ m/0.000012 in (Spindle), 1.0 μ m/0.00004 in (Anvil)
- Power source: SR44 battery (1 pc.), **938882** included as standard (for operational checks)
- Battery life: Approx. 2.4 years under normal use
- Position detection method: Electromagnetic rotary sensor
- Standard accessories: Spanner (**301336**), 1 pc. (for maximum measuring range up to 40 mm (1.6 in)), Setting Standards for V-Anvil Micrometer

Note: For functional details, refer to page 02-7.

The models above use the same connection cables and connection units as our IP rated micrometers but these digital V-Anvil Micrometers are not IP rated.

Measurement example



Pitch diameter measurement of tap by single-wire method

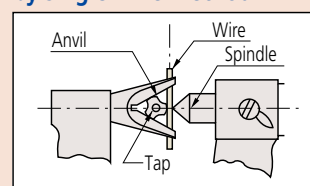

Optional Accessories

Code No.	Type	Description
264-020	—	USB Input Tool Series USB Keyboard Signal Conversion Type IT-020U
05CZA662	B	Connection cable (1 m)
05CZA663	B	Connection cable (2 m)
06AFM380B	B	USB Input Tool Direct (2 m)
02AZD730G	IP67	U-WAVE-T
02AZD880G	Buzzer	U-WAVE-T
02AZE200	—	U-WAVE-T mounting bracket
02AZD790B	B	Connection cable for U-WAVE-T (160 mm)
02AZE140B	B	Connection cable for U-WAVE-T For foot switch
264-622	IP67	U-WAVE-TM
264-623	Buzzer	U-WAVE-TM
264-626	IP67	U-WAVE-TMB
264-627	Buzzer	U-WAVE-TMB
02AZF310	IP67	Connecting unit for U-WAVE-TM/TMB

V-Anvil Micrometers SERIES 114 — 3 Flutes and 5 Flutes

- Measures the outside diameter of cutting tools (such as taps, reamers, end mills) with an odd number of flutes.
- Measures pitch diameter: refer to "Quick Guide to Precision Measuring Instruments" on page 13-8.
- Measuring faces: Carbide tipped
- Equipped with Ratchet Stop for constant measuring force.



114-121

SPECIFICATIONS

Metric For 3-flute cutting tools					
Code No.	Range (mm)	Graduation (mm)	Maximum permissible error J_{MPE} (μm)	Anvil	Remarks
Analog Anvil, Spindle (With carbide tip)					
114-204	2.3 - 25	0.01	± 4	60°	—
Analog Spindle (With carbide tip)					
114-101	1 - 15	0.01	± 4	60°	w/groove
114-102	10 - 25				—
114-103	25 - 40				—
114-104	40 - 55				—
114-105	55 - 70				—
114-106	70 - 85				—
114-107	85 - 100				—
114-108	100 - 115				—
114-109	115 - 130				—
114-110	130 - 145				—
114-161	1 - 15				± 4
114-162	10 - 25	± 4	—	—	

Inch For 3-flute cutting tools					
Code No.	Range (in)	Graduation (in)	Maximum permissible error J_{MPE} (in)	Anvil	Remarks
Analog Anvil, Spindle (With carbide tip)					
114-202	0.09 - 1	0.0001	± 0.0002	60°	—
Analog Spindle (With carbide tip)					
114-163	0.05 - 0.6	0.001	± 0.0002	60°	—
114-113	1 - 1.6		± 0.00025		—
114-114	1.6 - 2.2		± 0.0003		—

Metric For 5-flute cutting tools					
Code No.	Range (mm)	Graduation (mm)	Maximum permissible error J_{MPE} (μm)	Anvil	Remarks
Analog Anvil, Spindle (With carbide tip)					
114-137	2.3 - 25	0.01	± 4	108°	—
Analog Spindle (With carbide tip)					
114-121	5 - 25	0.01	± 4	108°	w/groove
114-122	25 - 45				—
114-123	45 - 65				—
114-124	65 - 85				—
114-165	5 - 25				± 4

Inch For 5-flute cutting tools					
Code No.	Range (in)	Graduation (in)	Maximum permissible error J_{MPE} (in)	Anvil	Remarks
Analog Anvil, Spindle (With carbide tip)					
114-135	0.09 - 1	0.0001	± 0.0002	108°	—

- Flatness: 0.6 μm /0.000024 in (Spindle), 1.3 μm /0.000052 in (Anvil)
- Standard accessories: Spanner (301336), 1 pc. (for 114-204, 202, 101, 102, 103, 104, 161, 162, 163, 113, 114, 137, 135, 121, 122, 165)
Spanner (200877), 1 pc. (for 114-105, 106, 107, 108, 109, 110, 123, 124)
Setting Standards for V-Anvil Micrometer

DIMENSIONS

Unit: mm

For 3-flute cutting tools	
Range (mm)	(g)
10 - 25	6.2
25 - 40	19.14
40 - 55	32.13
55 - 70	45.12
70 - 85	58.11

Micrometer

MeasurLink[®] ENABLED
Data Management Software by Mitutoyo

U-WAVE^{fit}

ABSOLUTE[™]

IP65

TÜV Rheinland
CERTIFIED
Dust- and
Water-
Protected
www.tuv.com
ID: 0000000313

Applicable models:
series 422 Quickmike type

Measurement example



Blade Micrometers

SERIES 422 — Non-rotating Spindle Type

- The anvil and the spindle have a blade for measuring the groove diameter of shafts, keyways and other hard-to-reach areas.
- Carbide-tipped measuring faces are available.
- Non-rotating spindle type.
- Equipped with Ratchet Stop for constant measuring force.



SPECIFICATIONS

Metric						
Code No.	Range (mm)	Resolution (mm)	Maximum permissible error J_{MPE} (μm)	Parallelism (μm)	Remark	
Digimatic						
422-230-30	0 - 25	0.001	±3	3	Type A	
422-231-30	25 - 50					
422-232-30	50 - 75					
422-233-30	75 - 100					
422-260-30	0 - 25		±3	3	Type B	
422-261-30	25 - 50					
422-270-30	0 - 25					Type C
422-271-30						

Inch / Metric						
Code No.	Range (in)	Resolution	Maximum permissible error J_{MPE} (in)	Parallelism (in)	Remark	
Digimatic						
422-330-30	0 - 1	0.00005 in/ 0.001 mm	±0.00015	0.00015	Type A	
422-331-30	1 - 2					
422-332-30	2 - 3					
422-333-30	3 - 4					
422-360-30	0 - 1		±0.00015	0.00015	Type B	
422-361-30	1 - 2					
422-370-30	0 - 1					Type C
422-371-30						

Metric Quickmike type					
Code No.	Range (mm)	Resolution (mm)	Maximum permissible error J_{MPE} (μm)	Parallelism (μm)	Remark
Digimatic					
422-411-20	0 - 30	0.001	±3	3	Type A
422-412-20	25 - 55				

Inch / Metric Quickmike type					
Code No.	Range (in)	Resolution	Maximum permissible error J_{MPE} (in)	Parallelism (in)	Remark
Digimatic					
422-421-20	0 - 1.2	0.00005 in/ 0.001 mm	±0.00015	0.00015	Type A
422-422-20	1 - 2.2				

- Power source: SR44 battery (1 pc.), **938882** included as standard (for operational checks)
- Battery life: Approx. 2.4 years under normal use (for **422-2XX, 3XX**)
Approx. 5 years under normal use (for **422-4XX**)
- Position detection method: Electromagnetic rotary sensor (for **422-2XX, 3XX**)
Electrostatic capacity absolute sensor (for **422-4XX**)
- Standard accessories: Setting standard, 1 pc. (except for measuring range 0 to 25 mm/0 to 30 mm (0 to 1 in/0 to 1.2 in) models), Spanner (**301336**), 1 pc. (for **422-2XX, 3XX**)

Note 1: For functional details, refer to page 02-7. Please note that these models are not water-proof.
Note 2: A heat shield is provided with Digimatic models as standard.

Type and dimensions

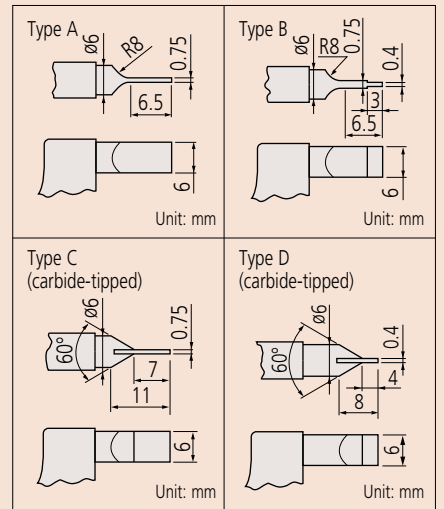

Optional Accessories

Code No.	Type	Description
05CZA662	B	Connection cable (1 m)
05CZA663	B	Connection cable (2 m)
06AFM380B	B	USB Input Tool Direct (2 m)
02AZD790B	B	Connection cable for U-WAVE-T (160 mm)
02AZE140B	B	Connection cable for U-WAVE-T For foot switch
264-622	IP67	U-WAVE-TM*
264-623	Buzzer	U-WAVE-TM*
264-626	IP67	U-WAVE-TMB*
264-627	Buzzer	U-WAVE-TMB*
02AZF310	IP67	Connecting unit for U-WAVE-TM/TMB*

* Only series 422 (except for Quickmike type) can be attached.

Deviation between the anvil and spindle in the vertical direction

within 0.15 mm
Deviation between the anvil and spindle in the vertical direction

Deviation of 0.15 mm or less* is guaranteed between the anvil and spindle in the vertical direction.
* When the measuring range is 0 to 25 mm

DIMENSIONS

Digimatic models up to 50 mm measuring range **Digimatic models over 50 mm to 100 mm measuring range** Unit: mm

Quickmike type

Code No.	L	a	b	C
422-230-30	0	11	31	12.5
422-231-30	25	12.2	50	12.6
422-232-30	50	14.6	57	13
422-233-30	75	16.7	76	16
422-260-30	0	11	31	12.5
422-261-30	25	12.2	50	12.6
422-270-30	0	11	31	12.5
422-271-30		8.5	36	13.5
422-411-20	25	8.5	36	
422-412-20		10.3	47	

Micrometer

Blade Micrometers SERIES 122 — Non-rotating Spindle Type

- The anvil and the spindle have a blade for measuring the groove diameter of shafts, keyways and other hard-to-reach areas.
- Non-rotating spindle type.
- Carbide-tipped measuring faces are available.
- Equipped with Ratchet Stop for constant measuring force.



122-101-10

SPECIFICATIONS

Metric					
Code No.	Range (mm)	Graduation (mm)	Maximum permissible error J_{MPE} (μ m)	Parallelism (μ m)	Remark
Analog					
122-101-10	0 - 25	0.01	± 3	3	Type A
122-102-10	25 - 50				
122-103-10	50 - 75				
122-104-10	75 - 100				
122-105-10	100 - 125				
122-106-10	125 - 150				
122-107-10	150 - 175		± 4	4	
122-108-10	175 - 200				
122-109-10	200 - 225				
122-110-10	225 - 250		± 5	5	
122-115-10	250 - 275				
122-116-10	275 - 300		± 6	6	
122-111-10	0 - 25				
122-112-10	25 - 50	± 3	3	Type B	
Analog (With carbide tip)					
122-161-10	0 - 25	0.01	± 3	3	Type C
122-162-10	25 - 50				
122-141-10	0 - 25			Type D	
122-142-10	25 - 50				

Inch					
Code No.	Range (in)	Graduation (in)	Maximum permissible error J_{MPE} (in)	Parallelism (in)	Remark
Analog					
122-125-10	0 - 1	0.0001	± 0.00015	0.00015	Type A
122-126-10	1 - 2				
122-127-10	2 - 3		± 0.0002	0.0002	
122-128-10	3 - 4				
122-135-10	0 - 1		± 0.00015	0.00015	Type B
122-151-10				Type D	

• Standard accessories: Setting standard, 1 pc. (except for measuring range 0 to 25 mm (0 to 1 in) models)
Spanner (301336), 1 pc.

Note: A heat shield is provided with 122-125-10, 122-135-10, 122-151-10 as standard.

DIMENSIONS

Analog models up to 25 mm measuring range

Unit: mm

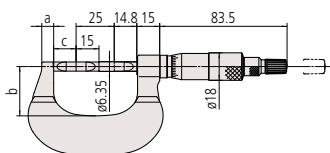

Analog models over 25 mm to 300 mm measuring range

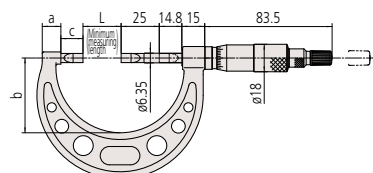

Code No.	L	a	b	C
122-101-10	0	7.8	32	15
122-102-10	25	12.2	49	14.5
122-103-10	50	14.6	60	
122-104-10	75	16.7	79	17.5
122-105-10	100	18.8	94	17.9
122-106-10	125	19.1	106	18.3
122-107-10	150	18.2	118	18.5
122-108-10	175	16.8	130	18.9
122-109-10	200	18	143	17.7
122-110-10	225		156	18.7
122-115-10	250		169	
122-116-10	275		181	

Can Seam Micrometers SERIES 147

- Measures the width, height, and depth of can seams.



147-103

Measurement example



SPECIFICATIONS

Metric				
Code No.	Range (mm)	Graduation (mm)	Maximum permissible error J_{MPE} (μ m)	Remarks
147-103*	0 - 13	0.01	± 3	—
147-105				for aluminum cans
147-202				for spray cans

Inch				
Code No.	Range (in)	Graduation (in)	Maximum permissible error J_{MPE} (in)	Remarks
147-104*	0 - 0.5	0.001	± 0.00015	—
147-106				for aluminum cans
147-201				for spray cans

- Standard Accessories: Spanner (200168), 1 pc. Spanner (202863), 1 pc.
- * For depth measurements up to 5 mm.

DIMENSIONS

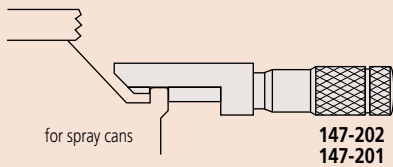
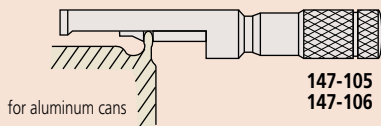
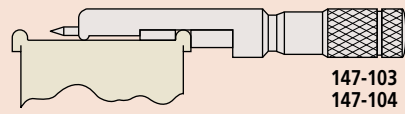
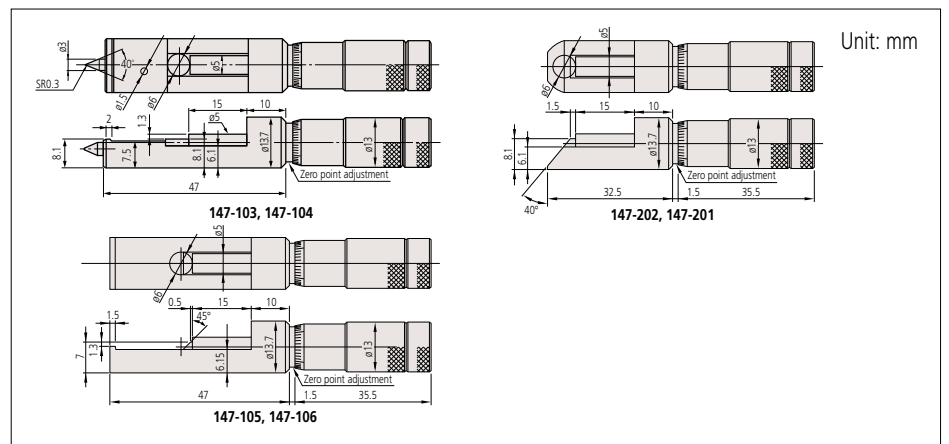

Hub Micrometers SERIES 147

- Measures hub thickness and shoulders inside a bore.
- Measuring faces: Carbide tipped
- Equipped with Ratchet Stop for constant measuring force.



147-301

Measurement example



SPECIFICATIONS

Metric					
Code No.	Range (mm)	Graduation (mm)	Maximum permissible error J_{MPE} (μ m)	Flatness (μ m)	Parallelism (μ m)
147-301	0 - 25	0.01	± 2	0.6	3
147-302	25 - 50				
147-303	50 - 75				
147-304	75 - 100		± 3		

Inch					
Code No.	Range (in)	Graduation (in)	Maximum permissible error J_{MPE} (in)	Flatness (in)	Parallelism (in)
147-351	0 - 1	0.001	± 0.0001	0.000024	0.00012
147-352	1 - 2				
147-353	2 - 3				
147-354	3 - 4		± 0.00015		

- Standard Accessories: Setting standard, 1 pc. (except for measuring range 0 to 25 mm (0 to 1 in) models), Spanner (301336), 1 pc.

DIMENSIONS

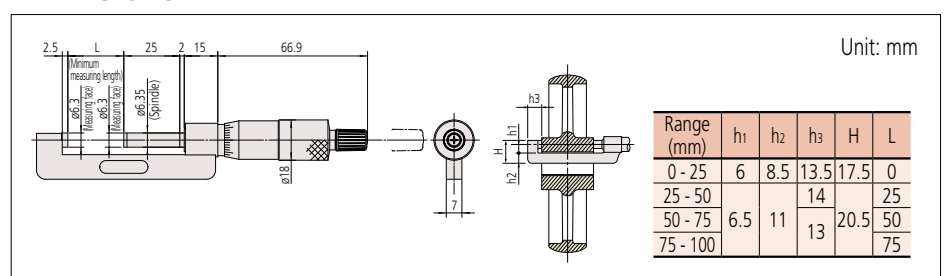

Micrometer



Dust- and Water- Protected
www.tuv.com ID: 00000191



Dust- and Water- Protected
www.tuv.com ID: 00000193

Measurement example



Crimp Height Micrometers SERIES 342

- Measures the height of crimp contacts.
- Point spindle
- IP65 water/dust protection (Digimatic model).
- Equipped with Ratchet Stop for constant measuring force.



Digimatic
342-271-30



Quickmike type
342-451-20

SPECIFICATIONS

Metric			
Code No.	Range (mm)	Resolution (mm)	Maximum permissible error J_{MPE} (μm)
Digimatic			
342-271-30	0 - 20	0.001	±3
Quickmike			
342-451-20	0 - 15	0.001	±3

Inch/Metric			
Code No.	Range (in)	Resolution	Maximum permissible error J_{MPE} (in)
Digimatic			
342-371-30	0 - 0.8	0.00005 in/ 0.001 mm	±0.00015

- Power source: SR44 battery (1 pc.), **938882** included as standard (for operational checks)
 - Battery life: Approx. 2.4 years under normal use (for **342-271-30/342-371-30**)
Approx. 5 years under normal use (for **342-451-20**)
 - Position detection method: Electromagnetic rotary sensor (for **342-271-30/342-371-30**)
Electrostatic capacity absolute sensor (for **342-451-20**)
 - Standard accessories: Spanner (**301336**), 1 pc. (except for **342-451-20**)
- Note: For functional details, refer to page 02-7.
Optional connection cable is available only for water-proof type (Digimatic model).

DIMENSIONS

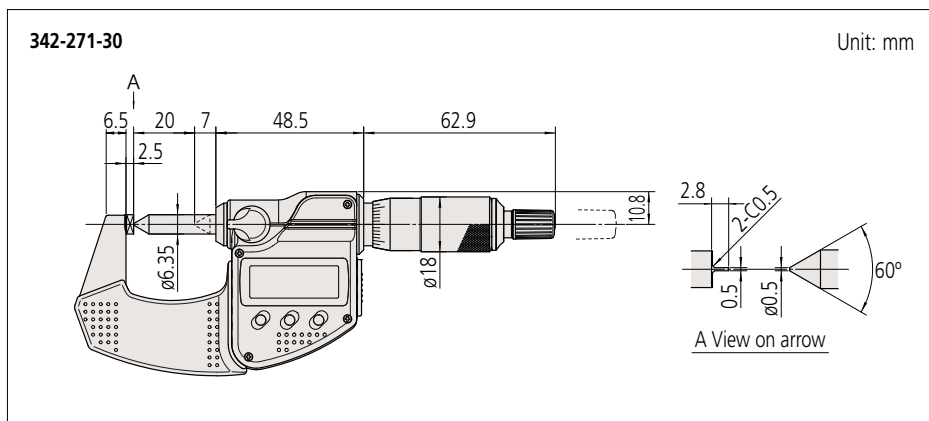

Anvil and spindle tip detail

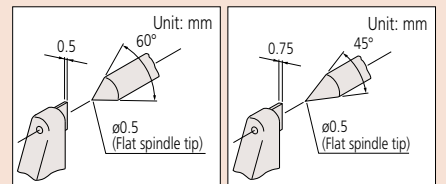

342-271-30, 342-371-30 342-451-20

Optional Accessories

Code No.	Type	Description
264-020	—	USB Input Tool Series USB Keyboard Signal Conversion Type IT-020U
05CZA662	B	Connection cable (1 m)
05CZA663	B	Connection cable (2 m)
06AFM380B	B	USB Input Tool Direct (2 m)
02AZD730G	IP67	U-WAVE-T
02AZD880G	Buzzer	U-WAVE-T
02AZE200	—	U-WAVE-T mounting bracket
02AZD790B	B	Connection cable for U-WAVE-T (160 mm)
02AZE140B	B	Connection cable for U-WAVE-T For foot switch
264-622	IP67	U-WAVE-TM*
264-623	Buzzer	U-WAVE-TM*
264-626	IP67	U-WAVE-TMB*
264-627	Buzzer	U-WAVE-TMB*
02AZF310	IP67	Connecting unit for U-WAVE-TM/TMB*

* **342-271-30** and **342-371-30** can be attached.
Not available for **342-451-20**.

Crimp Height Micrometers SERIES 112,142

- Measures the height of crimp contacts.
- Point spindle
- Equipped with Ratchet Stop for constant measuring force.



112-401

Anvil and spindle tip detail

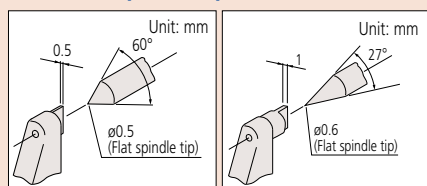

112-401

142-402, 142-403

SPECIFICATIONS

Metric			
Code No.	Range (mm)	Graduation (mm)	Maximum permissible error J_{MPE} (μm)
Mechanical counter model			
142-402	0 - 25	0.01	±3
142-403		0.001	

Metric			
Code No.	Range (mm)	Graduation (mm)	Maximum permissible error J_{MPE} (μm)
Analog			
112-401	0 - 25	0.01	±3

- Standard accessories: Spanner (301336), 1 pc.

Micrometer

MeasurLink[®] ENABLED
Data Management Software by Mitutoyo

U-WAVE^{fit}



Dust- and
Water-
Protected
www.tuv.com
ID: 000040191

Applicable models: **series 317**

"Uni-Mike" SERIES 317, 117 — Interchangeable Anvil Type

- Measures tubing thickness, shoulder-edge distance, rivet head height, etc., with interchangeable anvils (flat anvil, rod anvil, V-anvil).
- IP65 water/dust protection (**series 317**).
- Equipped with Ratchet Stop for constant measuring force.



317-251-30

SPECIFICATIONS

Metric					
Code No.	Range (mm)	Resolution (mm)	Spindle feed error (μm)	Flatness (μm)	Parallelism (μm)
Digimatic					
317-251-30	0 - 25	0.001	3	0.6 (Spindle face)/ 2 (Anvil face)	3
317-252-30	25 - 50				
Inch / Metric					
Code No.	Range (in)	Resolution	Spindle feed error (in)	Flatness (in)	Parallelism (in)
Digimatic					
317-351-30	0 - 1	0.00005 in/0.001 mm	0.00015	0.000024 (Spindle face)/ 0.00008 (Anvil face)	0.00012
317-352-30	1 - 2				

- Power source: SR44 battery (1 pc.), **938882** included as standard (for operational checks)
- Battery life: Approx. 2.4 years under normal use
- Position detection method: Electromagnetic rotary sensor
- Standard accessories: Setting standard, 1 pc. (except for measuring range 0 to 25 mm (0 to 1 in) models) Spanner (**301336**), 1 pc.

Note: For functional details, refer to page 02-7.
Optional connection cable is available only for water-proof type (Digimatic model).



117-101

SPECIFICATIONS

Metric					
Code No.	Range (mm)	Graduation (mm)	Spindle feed error (μm)	Flatness (μm)	Parallelism (μm)
Analog					
117-101	0 - 25	0.01	3	0.6 (Spindle face)/ 2 (Anvil face)	3
117-102	25 - 50				
Inch					
Code No.	Range (in)	Graduation (in)	Spindle feed error (in)	Flatness (in)	Parallelism (in)
Analog					
117-107	0 - 1	0.0001	0.00015	0.000024 (Spindle face)/ 0.00008 (Anvil face)	0.00012
117-108	1 - 2				

- Standard accessories: Setting standard, 1 pc. (except for measuring range 0 to 25 mm (0 to 1 in) models), Spanner (**200877**), 1 pc.

DIMENSIONS

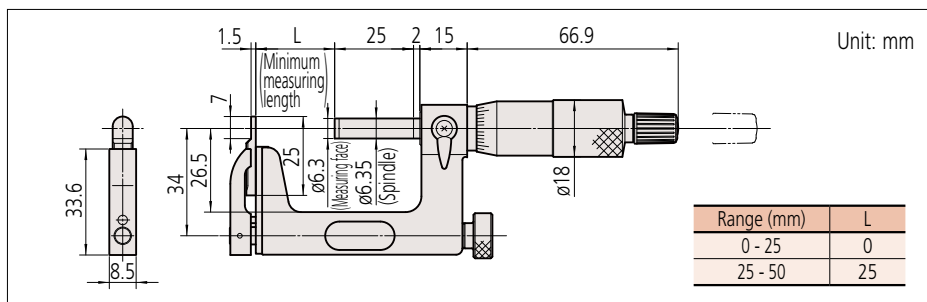

Measurement example



Optional Accessories

Code No.	Type	Description
264-020	—	USB Input Tool Series USB Keyboard Signal Conversion Type IT-020U
05CZA662	B	Connection cable (1 m)
05CZA663	B	Connection cable (2 m)
06AFM380B	B	USB Input Tool Direct (2 m)
02AZD730G	IP67	U-WAVE-T
02AZD880G	Buzzer	U-WAVE-T
02AZE200	—	U-WAVE-T mounting bracket
02AZD790B	B	Connection cable for U-WAVE-T (160 mm)
02AZE140B	B	Connection cable for U-WAVE-T For foot switch
264-622	IP67	U-WAVE-TM
264-623	Buzzer	U-WAVE-TM
264-626	IP67	U-WAVE-TMB
264-627	Buzzer	U-WAVE-TMB
02AZF310	IP67	Connecting unit for U-WAVE-TM/TMB

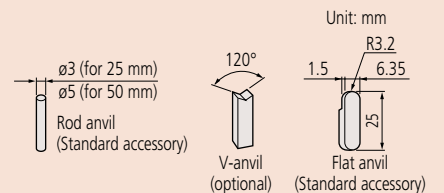

Code No.	Item
201216	Flat anvil (standard accessory)
201217	Rod anvil (standard accessory for 117-101/117-107/317-251-30/317-351-30)
201379	Rod anvil (standard accessory for 117-102/117-108/317-252-30/317-352-30)
201218	V-anvil (optional)
950758	Round Base for series 117 , for 0-25 mm Ø58x14.2 mm (optional)

Limit Micrometers SERIES 113

Measurement example



- Can be used as a Go/No-go gage by setting the upper and lower limits.
- Measuring faces: Carbide tipped



113-102

SPECIFICATIONS

Metric					
Code No.	Range (mm)	Graduation (mm)	Maximum permissible error J_{MPE} (μm)	Flatness (μm)	Parallelism (μm)
113-102	0 - 25	0.01	± 3	0.6	3
113-103	25 - 50				

• Standard Accessories: Setting standard, 1 pc. (except for measuring range 0 to 25 mm and 0 to 1 in models)
Spanner (200877), 1 pc.

DIMENSIONS

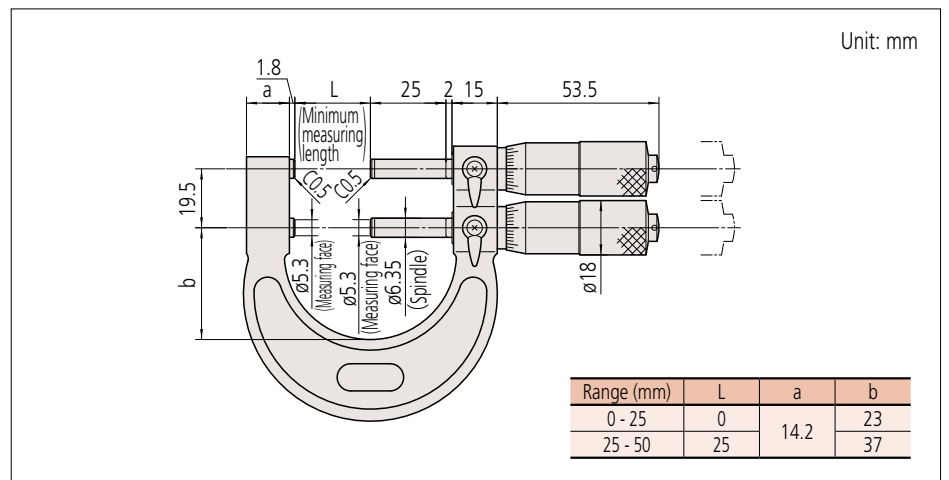

Micrometer



Indicating Micrometers SERIES 510

- The micrometer with a built-in dial indicator enables accurate Go/No-go judgement without interruption. Pushing the retractable anvil button causes the anvil and pointer to move, enabling speedy measurements.
- Easy to use when operating one-handed due to retractable anvil.
- In the 25 mm measuring range, models are available that offer left or right positioning of the anvil-retraction button.
- Greatly improved accuracy: indication error and graduation of 1 μm .
- IP protection level: 54, coolant-splash resistant during grinding process.



510-121

SPECIFICATIONS

Metric												
Code No.	Range (mm)	Spindle feed error (μm)	Flatness (μm)	Parallelism (μm)	Dispersion of indication (μm)	Dial indication accuracy (μm)	Indicating range (mm)	Graduation (mm)	Dial graduation (mm)	Measuring force (N)	Anvil retraction button	Mass (g)
510-121	0 - 25	3	0.3	0.6	0.4	1	± 0.06	0.001	0.001	5 - 10	Right side	520

Inch												
Code No.	Range (in)	Spindle feed error (in)	Flatness (in)	Parallelism (in)	Dispersion of indication (in)	Dial indication accuracy (in)	Indicating range (in)	Graduation (in)	Dial graduation (in)	Measuring force (N)	Anvil retraction button	Mass (g)
510-131	0 - 1	0.00015	0.000012	0.000024	0.00002	0.00005	± 0.0023	0.0001	0.00005	5 - 10	Right side	520

• Standard Accessories: Spanner (200154), 1 pc.

Measurement example



Workpiece stop (optional)

- Produces more stable measurement.
- Three types are available to suit workpieces of different sizes.

Range	Unit: mm	
	A	B
Workpiece stop A 04AZA124	$\phi 16$	23
Workpiece stop B 04AZA125	$\phi 14$	20.5
Workpiece stop C 04AZA126	$\phi 14$	15

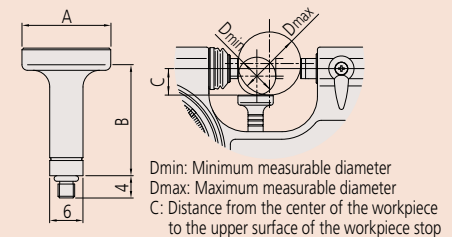

• Code No. 510-121, 510-141, 510-131, 510-151 Unit: mm

	Dmin	Dmax	C
Workpiece stop A	N/A	N/A	N/A
Workpiece stop B	4	16	5.0
Workpiece stop C	15	25	10.5

• 510-122 and 510-132

	Dmin	Dmax	C
Workpiece stop A	25	37	15.5
Workpiece stop B	30	42	18.0
Workpiece stop C	41	50	23.5

• 510-123 and 510-133

	Dmin	Dmax	C
Workpiece stop A	50	61	27.5
Workpiece stop B	54	66	30.0
Workpiece stop C	65	75	35.5

• 510-124 and 510-134

	Dmin	Dmax	C
Workpiece stop A	75	87	40.5
Workpiece stop B	80	92	43.0
Workpiece stop C	91	100	48.2

DIMENSIONS

Up to 25 mm measuring range (anvil-retraction button on the right side)

Unit: mm

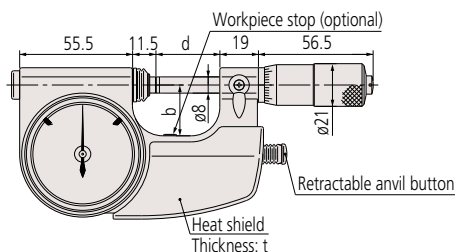

Range (mm)	b	d	t
0 - 25	25	31.5	16.4

Measurement example



510-141

SPECIFICATIONS

Metric

Code No.	Range (mm)	Spindle feed error (μm)	Flatness (μm)	Parallelism (μm)	Dispersion of indication (μm)	Dial indication accuracy (μm)	Indicating range (mm)	Graduation (mm)	Dial graduation (mm)	Measuring force (N)	Anvil retraction button	Mass (g)
510-141	0 - 25	3	0.3	0.6	0.4	1	±0.06	0.001	0.001	5 - 10	Left side	530
510-122	25 - 50			670								
510-123	50 - 75			820								
510-124	75 - 100			970								

Inch

Code No.	Range (in)	Spindle feed error (in)	Flatness (in)	Parallelism (in)	Dispersion of indication (in)	Dial indication accuracy (in)	Indicating range (in)	Graduation (in)	Dial graduation (in)	Measuring force (N)	Anvil retraction button	Mass (g)
510-151	0 - 1	0.00015	0.00012	0.00024	0.00002	0.00005	±0.0023	0.0001	0.00005	5 - 10	Left side	530
510-132	1 - 2			670								
510-133	2 - 3			820								
510-134	3 - 4			970								

• Standard Accessories: Setting standard, 1 pc. (except for measuring range 0 to 25 mm (0 to 1 in) models)
Spanner (200154), 1 pc.

DIMENSIONS

Up to 25 mm measuring range
(anvil-retraction button on the left side)

Over 25 mm measuring range
(anvil-retraction button on the left side)

Unit: mm

Range (mm)	b	d	t
0 - 25	25	31.5	16.4
25 - 50	38	56.5	16
50 - 75	50	81.5	
75 - 100	63	106.5	

Micrometer



Dial Snap Meters SERIES 523

- The snap meter with a built-in dial indicator enables accurate Go/No-go judgement without interruption. Pushing the retractable anvil button causes the anvil and pointer to move, enabling speedy measurements.
- Designed for use with a stand to enable a more stable measurement.
- Greatly improved accuracy: indication accuracy and graduation of 1 μm .
- IP protection level: 54, coolant-splash resistant during grinding process.
- Hard-coated crystal: enhanced oil and scratch resistance.



523-121

SPECIFICATIONS

Metric									
Code No.	Range (mm)	Dial graduation (mm)	Measuring force (N)	Flatness (μm)	Parallelism (μm)	Dispersion of indication (μm)	Dial indication accuracy (μm)	Indicating range (mm)	Mass (g)
523-121	0 - 25	0.001	5 - 10	0.3	0.6	0.4	1	± 0.06	740
523-122	25 - 50				840				
523-123	50 - 75				950				
523-124	75 - 100				1080				

Inch									
Code No.	Range (in)	Dial graduation (in)	Measuring force (N)	Flatness (in)	Parallelism (in)	Dispersion of indication (in)	Dial indication accuracy (in)	Indicating range (in)	Mass (g)
523-131	0 - 1	0.00005	5 - 10	0.000012	0.000024	0.00002	0.00005	± 0.0023	740
523-132	1 - 2				840				
523-133	2 - 3				950				
523-134	3 - 4				1080				

DIMENSIONS

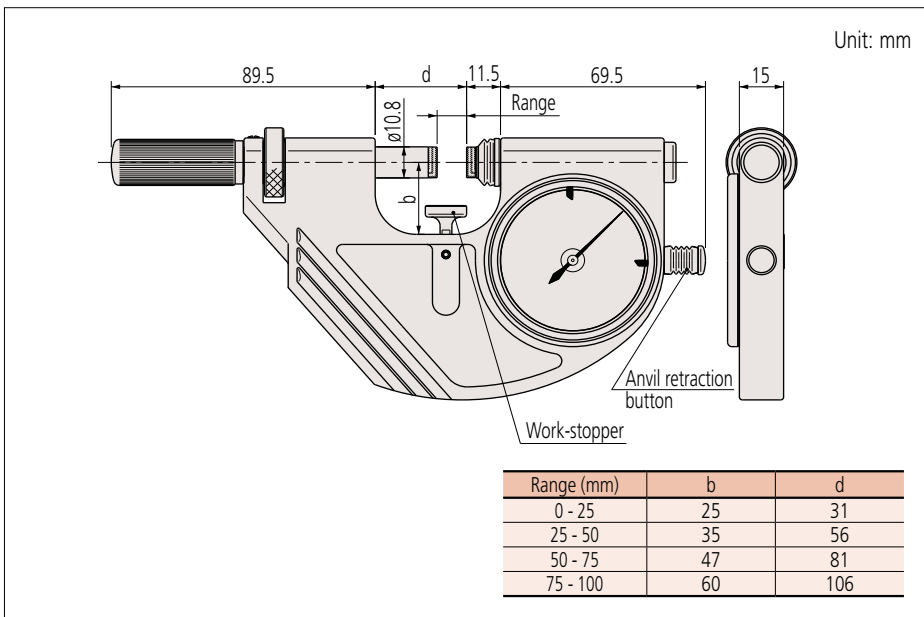

Measurement example



Snap Meters SERIES 523

Mounting example



ABS Digimatic Indicator



Linear Gage and counter

Typical indicators used with gage

- ID-C (0.0005 mm): **543-700B**
- LGF-L (0.0001 mm): **542-192** & Counter **542-075** & Conversion plug **21HZA195**

- The snap meter with an external indicator enables accurate Go/No-go judgement without interruption. Pushing the retractable anvil button causes the anvil and pointer to move, enabling speedy measurements.
- Select your preferred indicator. The measurement result can be externally output using an indicator with an output function.
- Measuring faces: Carbide tipped



523-141
(Indicator: optional)

SPECIFICATIONS

Metric							
Code No.	Range (mm)	Anvil movement (mm)	Measuring force* (N)	Repeatability of indication (μm)	Flatness (μm)	Parallelism (μm)	Mass (g)
523-141	0 - 25	2	5 - 10	0.4	0.3	0.6	710
523-142	25 - 50						810
523-143	50 - 75					920	
523-144	75 - 100					1050	

Inch							
Code No.	Range (in)	Anvil movement (in)	Measuring force* (N)	Repeatability of indication (in)	Flatness (in)	Parallelism (in)	Mass (g)
523-151	0 - 1	0.078	5 - 10	0.00002	0.000012	0.000024	710
523-152	1 - 2						810
523-153	2 - 3					920	
523-154	3 - 4					1050	

* Measuring force before an indicator is mounted.
Measured at the position where the anvil is retracted by 1 mm from the free position without installing the indicator.

DIMENSIONS

Unit: mm

Range (mm)	b	d
0 - 25	25	31
25 - 50	35	56
50 - 75	47	81
75 - 100	60	106

Micrometer

Groove Micrometers SERIES 146

- Flanged spindle and anvil for measuring width and location of grooves inside bores and tubes.
- Two-directional ratchet stop.
- For OD (except for 0 - 25 mm) and ID measurements, a master gage is required for adjusting the reference point.
- Non-rotating spindle.



146-221

Measurement example

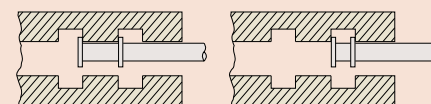

SPECIFICATIONS

Metric						
Code No.	Range Inside (mm)	Range Outside (mm)	Graduation (mm)	Maximum permissible error J_{MPE} (μm)	Parallelism (μm)	Flange (mm)
146-221	1.6 - 26.5	0 - 25	0.01	± 10	10	$\varnothing 6.35$
146-222						$\varnothing 12.7$
146-223	26.5 - 51.5	25 - 50				$\varnothing 12.7$
146-224	51.5 - 76.5	50 - 75				$\varnothing 12.7$
146-225	76.5 - 101.5	75 - 100				$\varnothing 12.7$

Inch						
Code No.	Range Inside (in)	Range Outside (in)	Graduation (in)	Maximum permissible error J_{MPE} (in)	Parallelism (in)	Flange (in)
146-231	0.055 - 1.05	0 - 1	0.001	± 0.0004	0.0004	$\varnothing 0.25$
146-232						$\varnothing 0.5$
146-233	1.05 - 2.05	1 - 2				$\varnothing 0.5$
146-234	2.05 - 3.05	2 - 3				$\varnothing 0.5$
146-235	3.05 - 4.05	3 - 4				$\varnothing 0.5$

- Standard accessories: Spanner (301336), 1 pc.

DIMENSIONS

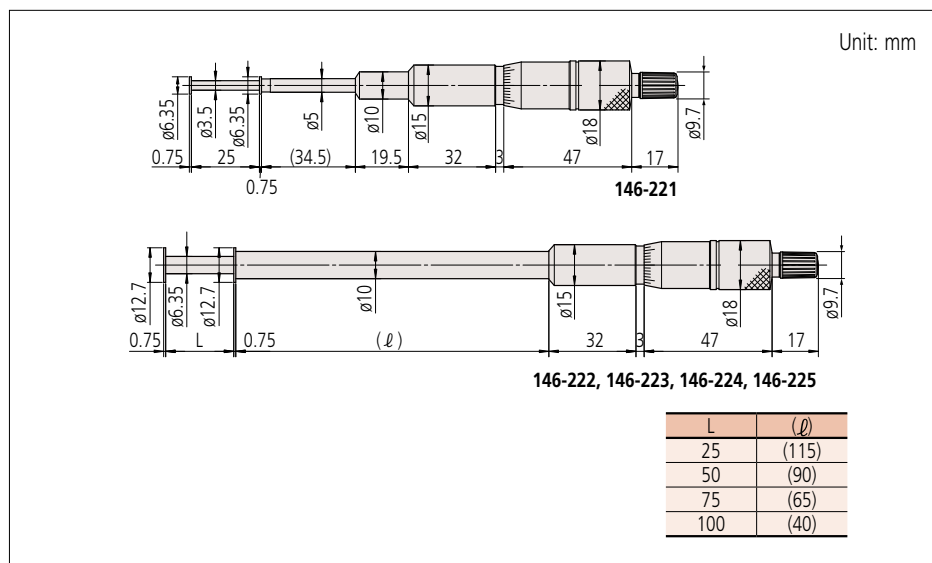

QUICKmini SERIES 700

Measurement example



Functions

ABS measurement function:

after a data is displayed, next measurement can be performed without zero-setting. Also, the ABS origin point can be changed with ORIGIN switch.

INC measurement function:

clears the displayed data at any point. The comparative measurement can be easily performed.

Low battery alarm:

notifies that the battery is wearing down with "B" mark before becoming immeasurable. Thus, the timing for battery replacement can be confirmed in advance.

Typical applications:

- Measurement of small workpieces:

Pearl, jewel, engine tappet shim, screws.

- Measurement of thin workpieces:

Printing paper, polyethylene bags, sheet material, noodles and other food products, medium substrate, foil, thin plate, filter cloth and other medical supplies.

- Measurement of thin lines and bars: Fishing line, dental reamers, spaghetti, drill for PCBs, wiring.

- Lightweight and palm-sized.
- Highly suitable for quick dimensional inspection of small, thin and delicate objects.



700-119-30

SPECIFICATIONS

Metric						
Code No.	Range (mm)	Resolution (mm)	Accuracy* (mm)	Maximum response speed	Measuring force (N)	Mass (g)
700-119-30	0 - 12	0.01	±0.02	Unlimited	2 or less	100

Inch / Metric						
Code No.	Range (in)	Resolution	Accuracy* (in)	Maximum response speed	Measuring force (N)	Mass (g)
700-118-30	0 - 0.5	0.0005 in/0.01 mm	±0.001	Unlimited	2 or less	100

• Power source: SR44 battery (1 pc.), **938882** included as standard (for operational checks)

• Battery life: Approx. 5 years under normal use

* Excluding quantizing error of ±1 count

DIMENSIONS

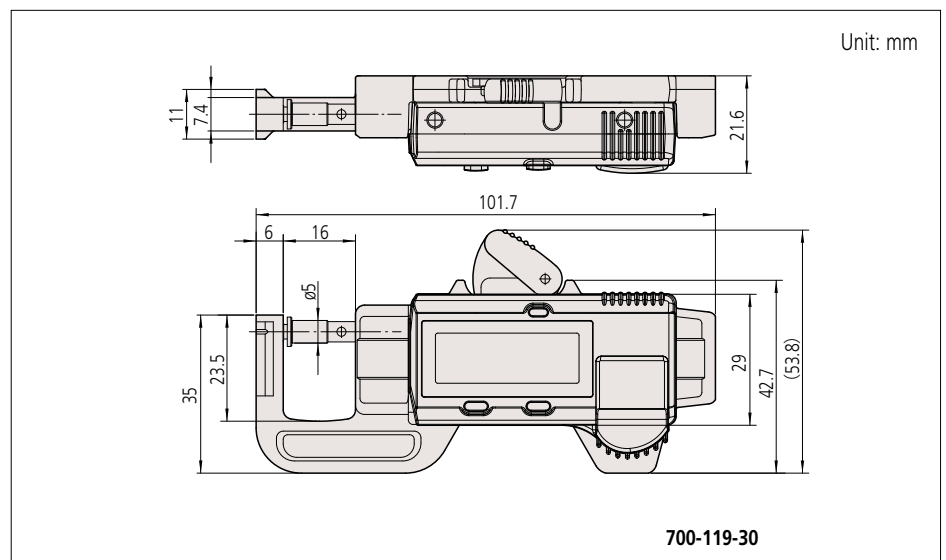

700-119-30

Micrometer

Telescoping Gage Set SERIES 155

- The tools are for comparing and measuring the diameters of extremely small holes or the widths of narrow grooves that are hard to measure with the other measuring instruments.
- A spring-loaded plunger expands within a bore (or groove) and is locked in place allowing diameter measurements (or width) with an outside micrometer after extraction.



155-905

Typical application



SPECIFICATIONS

Metric	
Code No.	Range (mm)
6-gage Set	
155-905	8 - 150
Gages included	
155-127	8 - 12.7
155-128	12.7 - 19
155-129	19 - 32
155-130	32 - 54
155-131	54 - 90
155-132	90 - 150
5-gage Set	
155-904	0.5 - 6
Gages included	
155-122	0.5 - 0.75
155-123	0.75 - 1.25
155-124	1.25 - 2.125
155-125	2.125 - 3.5
155-126	3.5 - 6

Inch	
Code No.	Range (in)
6-gage Set	
155-903	0.313 - 6
Gages included	
155-121	0.313 - 0.5
155-122	0.5 - 0.75
155-123	0.75 - 1.25
155-124	1.25 - 2.125
155-125	2.125 - 3.5
155-126	3.5 - 6
4-gage Set	
155-907	0.313 - 2.125
Gages included	
155-121	0.313 - 0.5
155-122	0.5 - 0.75
155-123	0.75 - 1.25
155-124	1.25 - 2.125

DIMENSIONS

Unit: mm

Range (mm)	L	øD	ød1	ød2
8 - 12.7	110	5	4	3
12.7 - 19		5.5	5	3.5
19 - 32				
32 - 54	150	8	7.5	6
54 - 90				
90 - 150				

Optical Parallels SERIES 157

Typical application



- Designed to inspect parallelism and flatness of measuring faces of micrometers. For details, refer to "Quick Guide to Precision Measuring Instruments" on page 13-9.
- Each set consists of 4 sizes to enable testing parallelism at quarter-turn positions of the micrometer spindle.



157-903

SPECIFICATIONS

Metric						
Code No.	Range of micrometer to be checked (mm)	Sizes of parallels included in set (mm)	Diameter (mm)	Flatness (μm)	Parallelism (μm)	Remarks (mm)
157-903	0 - 25	12.00, 12.12, 12.25, 12.37	ø30	0.1	0.2	For 25
157-904	25 - 50	25.00, 25.12, 25.25, 25.37				For 50

Inch						
Code No.	Range of micrometer to be checked (in)	Sizes of parallels included in set (in)	Diameter (mm)	Flatness (μm)	Parallelism (μm)	Remarks (mm)
157-901	0 - 1	0.5000, 0.5062, 0.5125, 0.5187	ø30	0.1	0.2	For 25
157-902	1 - 2	1.0000, 1.0062, 1.0125, 1.0187				For 50

Note: Also available individually, using the following Code No.

Metric		Metric	
Code No.	Thickness (mm)	Code No.	Thickness (mm)
157-101	12.00	157-105	25.00
157-102	12.12	157-106	25.12
157-103	12.25	157-107	25.25
157-104	12.37	157-108	25.37

Inch		Inch	
Code No.	Thickness (in)	Code No.	Thickness (in)
157-109	0.5000	157-113	1.0000
157-110	0.5062	157-114	1.0062
157-111	0.5125	157-115	1.0125
157-112	0.5187	157-116	1.0187

Optical Flats SERIES 158

Typical application

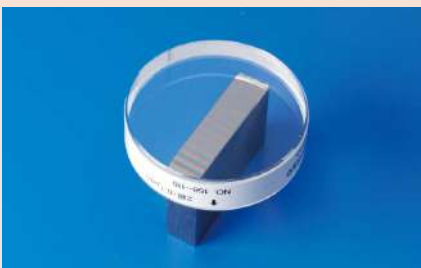

- Used for inspecting the flatness of measuring faces with high accuracy. For details, refer to "Quick Guide to Precision Measuring Instruments" on page 13-9.



158-118

SPECIFICATIONS

Metric			
Code No.	Thickness (mm)	Diameter (mm)	Flatness grade (μm)
158-117	12	45	0.2
158-118			0.1
158-119	15	60	0.2
158-120			0.1

Inch			
Code No.	Thickness (in)	Diameter (in)	Flatness grade (in)
158-121	0.5	1.8	0.000008
158-122			0.000004
158-123	0.6	2.4	0.000008
158-124			0.000004

Micrometer

Setting Standards for Outside Micrometers SERIES 167

- Used for setting the zero point on outside micrometers.



167-108

SPECIFICATIONS and DIMENSIONS

167-101 to 167-103
167-141 to 167-143

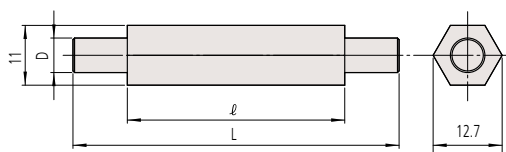

Unit: mm

Metric						
Code No.	Length <L> (mm)	Accuracy (μm)	Parallelism (μm)	Flatness (μm)	l (mm)	Diameter <D> (mm)
167-101	25	± 1.5	2.0	0.3	18	6.35
167-102	50	± 2.0			40	
167-103	75	± 2.5			40	

Inch						
Code No.	Length <L> (in)	Accuracy (in)	Parallelism (in)	Flatness (in)	l (mm)	Diameter <D> (in)
167-141	1	± 0.00005	0.00008	0.000012	18	0.25
167-142	2	± 0.0001			40	
167-143	3	± 0.0001			40	

167-104 to 167-107
167-144 to 167-147

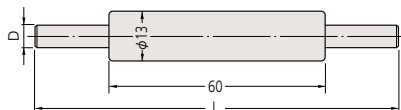

Unit: mm

Metric					
Code No.	Length <L> (mm)	Accuracy (μm)	Parallelism (μm)	Flatness (μm)	Diameter <D> (mm)
167-104	100	± 3	2.0	0.3	7.9
167-105	125	± 3.5			
167-106	150	± 4			
167-107	175	± 4.5			

Inch					
Code No.	Length <L> (in)	Accuracy (in)	Parallelism (in)	Flatness (in)	Diameter <D> (in)
167-144	4	± 0.0001	0.00008	0.000012	0.31
167-145	5	± 0.00015			
167-146	6				
167-147	7				

167-108 to 167-119
167-148 to 167-159

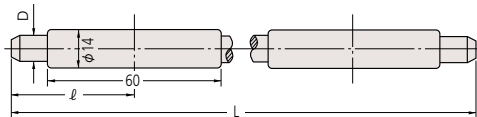

Unit: mm

Metric						
Code No.	Length <L> (mm)	Accuracy (μm)	Parallelism (μm)	Flatness (μm)	l (mm)	Diameter <D> (mm)
167-108	200	± 5.0	2.0	0.3	47	9.4
167-109	225	± 5.5			52	
167-110	250	± 6.0			57	
167-111	275	± 6.5			64	
167-112	300	± 7			69	
167-113	325	± 7.5			74	
167-114	350	± 8			80	
167-115	375	± 8.5			85	
167-116	400	± 9			90	
167-117	425	± 9.5			95	
167-118	450	± 10			101	
167-119	475	± 10.5				

Inch						
Code No.	Length <L> (in)	Accuracy (in)	Parallelism (in)	Flatness (in)	l (mm)	Diameter <D> (in)
167-148	8	± 0.00015	0.00008	0.000012	47	0.37
167-149	9	± 0.0002			52	
167-150	10	± 0.0002			57	
167-151	11	± 0.0002			64	
167-152	12	± 0.00025			69	
167-153	13	± 0.00025			74	
167-154	14	± 0.00025			80	
167-155	15	± 0.00025			85	
167-156	16	± 0.00025			90	
167-157	17	± 0.00025			95	
167-158	18	± 0.00025			101	
167-159	19	± 0.0003				

Typical application



Micrometer Inspection Gauge Block Set

Refer to page 01-13 for details.



516-152/153/154



Micro Checker (holder only)
516-607

Micrometer

Setting Standards for Screw Thread Micrometers SERIES 167

- Used to set the zero point of screw thread micrometers.



167-264
(60° screw)

Metric		
Code No.	Length <L> (mm)	Accuracy (μm)
Metric (unified) $\theta=60^\circ$		
167-261	25	±4
167-262	50	±5
167-263	75	±6
167-264	100	±7
167-265	125	±8
167-266	150	±9
167-267	175	±10
167-268	200	±11
167-269	225	±12
167-270	250	±13
167-271	275	±14
Whitworth $\theta=55^\circ$		
167-272	25	±4
167-273	50	±5
167-274	75	±6
167-275	100	±7
167-276	125	±8
167-277	150	±9
167-278	175	±10
167-279	200	±11
167-280	225	±12
167-281	250	±13
167-282	275	±14

Inch		
Code No.	Length <L> (in)	Accuracy (in)
Metric (unified) $\theta=60^\circ$		
167-294	1	±0.00015
167-295	2	±0.0002
167-296	3	±0.00025
167-297	4	±0.0003
167-298	5	±0.00035
167-299	6	±0.0004
Whitworth $\theta=55^\circ$		
167-283	1	±0.00015
167-284	2	±0.0002
167-285	3	±0.00025
167-286	4	±0.0003
167-287	5	±0.00035
167-288	6	±0.0004

Typical application



Setting Standards for V-anvil Micrometers SERIES 167

- Used for setting the zero point of V-anvil micrometers.



Metric			
Code No.	Length <L> (mm)	Accuracy (μm)	Type
167-327	5	±2	Plug
167-328	10		
167-329	25		
167-330	40	±3	Ring
167-331	55		
167-332	70		
167-333	85		
167-334	100		
167-335	115	±5	
167-336	130		

Inch			
Code No.	Length <L> (in)	Accuracy (in)	Type
167-337	0.2	±0.0001	Plug
167-338	0.4		
167-339	1		
167-340	1.6	±0.00015	Ring

Typical application



3-Wire Units SERIES 313

Measurement example



- Enables pitch diameter measurements of screw threads when attached to the measuring faces of both the spindle and anvil of a micrometer.
- Determination of the pitch diameter: refer to "Quick Guide to Precision Measuring Instruments" on page 13-8.



SPECIFICATIONS

Code No. (One pair) (Support spindle dia.)	Wire dia. (mm)	Accuracy of wire diameter (mm)	Pitch		
			Metric thread (mm)	Unified thread (threads per inch)	Whitworth thread (threads per inch)
6.35 mm (0.25 in)					
952131	0.170	±0.002	0.2, 0.25, 0.3	80	—
952132	0.195		0.35	72	—
952133	0.220		0.4	64	—
952134	0.250		0.45	56	60
952135	0.290		0.5	48	48
952136	0.335		0.6	44, 40	40
952137	0.390		0.7	36	36
952138	0.455		0.75, 0.8	32	32
952139	0.530		0.9	28	28, 26
952140	0.620		1.0	24	24, 22
952141	0.725		1.25	20	20, 19, 18
952142	0.895		1.5	18, 16	16
952143	1.100		1.75, 2.0	14, 13, 12	14, 12
952144	1.350		2.5	11, 10	11, 10
952145	1.650		3.0	9, 8	9, 8
952146	2.050		3.5	7	7
952147	2.550		4, 4.5	6	6
952148	3.200		5, 5.5, 6	5, 4.5	5, 4.5

3-Wire Units set

Code No.	Set	Wire dia. (mm)	Support spindle dia. (mm)
313-101	18	0.170 - 3.200	6.35

Note 1: Special-specification 3-wire units with a wire diameter other than those listed above (ø0.15 mm or more) can also be made to order.

Note 2: Due to potential obstruction, the 3-wire unit cannot be used with screws having an external diameter exceeding ø50 mm.

Lubricant for Measuring Tools

- The oil is for maintaining measuring tools.

Note: May not be used for some parts such as the spindle of a dial indicator or Digimatic indicator.



SPECIFICATIONS

Code No.	Product name	Remarks
207000*	Micrometer oil	Grease (32 ml)

* Not available in certain countries and regions.

Micrometer

Color-Coded Ratchet and Speeder Covers

- Ratchet and speeder covers in a choice of seven colors for use in instrument identification control schemes: red, blue, yellow, green, brown, black and gray.

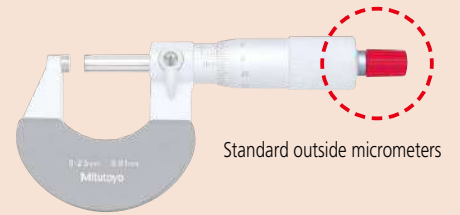

SPECIFICATIONS

Analog type: 0 to 300 mm

Code No.		Color	Material
Ratchet	Speeder		
04GZA239	04GAA260	Gray	Plastic
985056	301708	Black	
985061	301709	Red	
985081	301713	Blue	
985071	301711	Yellow	
985076	301712	Green	
985066	301710	Brown	
950700	—	Gray	Steel

Analog/Digimatic types: 300 to 1000 mm

Code No.		Color	Material
Ratchet	Speeder		
04GZA243	04GAA260	Gray	Plastic
—	301708	Black	
—	301709	Red	
—	301713	Blue	
—	301711	Yellow	
—	301712	Green	
—	301710	Brown	
950701	—	Gray	Steel

Digimatic type 0 to 300 mm*

Code No.*		Color	Material
Ratchet	Speeder		
04AZB661	04GAA260	Gray	Plastic
04GZA241	04GAA260	Gray	
—	301708	Black	
—	301709	Red	
—	301713	Blue	
—	301711	Yellow	
—	301712	Green	
—	301710	Brown	
951588	—	Gray	Steel

* Cannot be used for analog types.

Color-coded speeder covers



SPECIFICATIONS

Code No.	Color
04GAA899	Black
04GAA900	Red
04GAA901	Yellow
04GAA902	Green
04GAA903	Blue
04AAB208	Gray

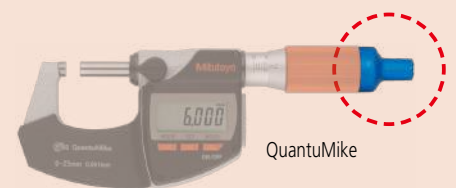

Micrometer Stands SERIES 156

Typical application



156-101-10

- Dedicated stand for micrometers.



156-101-10

- Designed to allow benchtop use of hand-held micrometers or other gages which have frames suitable for gripping by the clamp. Reduces the influence of temperature changes due to body heat, enabling higher-accuracy measurement.

SPECIFICATIONS

Code No.	Measuring range of standard outside micrometer	Remarks
156-101-10	15 - 100 mm (0.6 - 4 in)*	Adjustable angle type

* Items that cannot be mounted on these stands (Code No. 406-253-30, 323-253-30, 331-254-30, 342-254-30, 342-264-30, 369-253-30, 422-232-30, 422-233-30, etc.)

DIMENSIONS

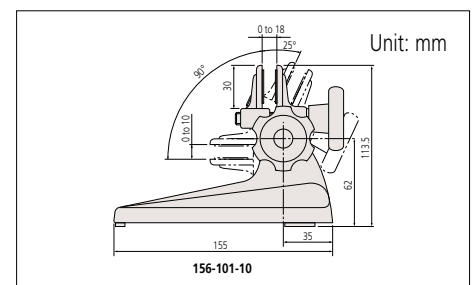

Typical application



156-105-10



156-105-10

SPECIFICATIONS

Code No.	Measuring range of standard outside micrometer	Remarks
156-105-10	25, 50 mm (1, 2 in)	Fixed angle type

DIMENSIONS

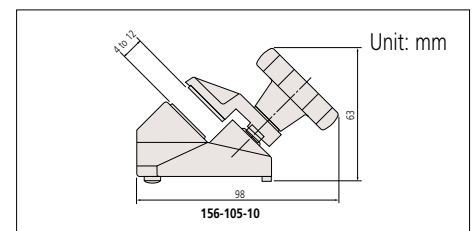

Typical application



156-102

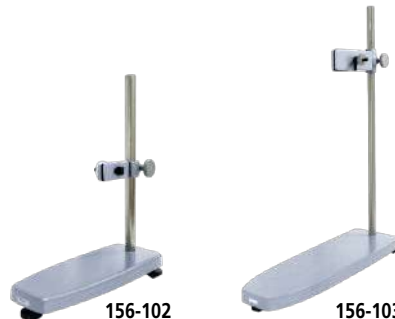

156-102

156-103

SPECIFICATIONS

Code No.	Measuring range of standard outside micrometer	Remarks
156-102	100 - 300 mm (4 - 12 in)	Vertical type
156-103	325 - 1000 mm (13 - 40 in)	Vertical type

DIMENSIONS

