

CODE U2525

**UNIQUE PRECISION HIGH GRIP SELF CENTERING SHAFT VISE**  
(HARDENED GUIDE WAYS)

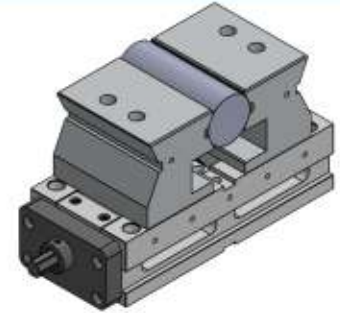

**REVERSIBLE JAWS**



**FEATURES**

- Compact, rigid and specially designed for accurate centering of round jobs on precision for precision milling, grinding & CNC Operations.
- High quality alloy steel jaws, case hardened to HRC 60 ± 2.
- High quality FCD 60 vise body, with flame hardened guideways for better wear resistance.
- Top and bottom vise faces are parallel well within ± 0.02 mm / 100 mm.
- High accuracy in squareness, within 0.02 mm / 100 mm.
- Tenon and Tenon slots are provided for effortless truing of the machine vise to the machine table.
- Jaws are reversible, so as to provide additional clamping range.

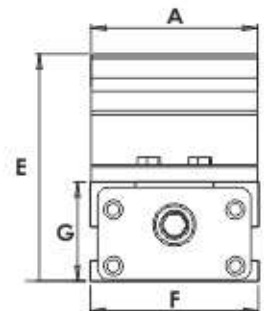
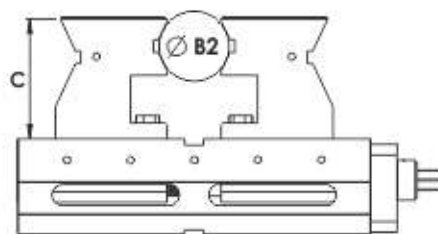
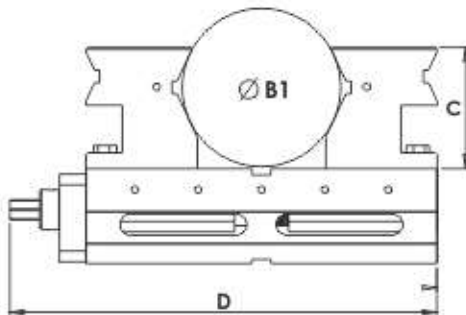
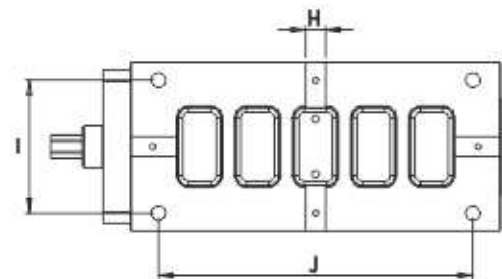

Jaw Width	Openings		All dimensions in mm									
	A	B1	B2	C	D	E	F	G	H	I	J	Weight (Kgs)
150	40-100	20-40	80	320	150	151	70	20	100	250	25	5000
	50-150	30-50	115	500	205		90		120	400		